



User's Guide WAQPRE





# User's Guide WAQPRE

Version number : Version 10.127, May 2012  
Maintenance : see [www.helpdeskwater.nl/waqua](http://www.helpdeskwater.nl/waqua)  
Copyright : Rijkswaterstaat

## Log-sheet

document version	date	Changes with respect to the previous version
10.43	June 2006	Simona major release 2006-01
10.44	21-07-2006	c61168: added option to control amount of output of iterative procedures
10.45	22-10-2006	c65666: added non-hydrostatic option to TRIWAQ
10.46	09-11-2006	c65667: added horizontal k-epsilon turbulence model to TRIWAQ
10.47	30-11-2006	c67309: exchanged simple functionality between WAQUA and TRIWAQ
10.48	13-12-2006	c68134: allow Nikuradse and Roughcombination in 3D runs
10.49	27-12-2006	c68932: added incremental-option
10.50	28-12-2006	m288409: extended roughcombination codes from 1900 to 1999
10.51	03-01-2007	c68133: added combinations of roughcombination
10.52	17-01-2007	c67722: added Gauss-Kruger coordinates
10.53	05-02-2007	c68666: added iteration parameters for transport equation
10.54	13-02-2007	c70161: added conditional time for barriers
10.55	16-05-2007	c66699: added linear bottom friction
10.56	23-05-2007	c73245: sill depths for weirs made optional
10.57	18-06-2007	c71236: CCO-file option removed; old drying/flooding keywords (IDRYFLAG,DUPWND) no longer operational; old iter keyword (ITERACCURACY) no longer operational; keyword CDCON removed
10.58	26-06-2007	c70822: advise for choosing TSTEP that can be represented binary
10.59	05-09-2007	p5455: recovered missing figures and equations
10.60	17-09-2007	c74807: energyloss for weirs separate from Chezy-term
10.61	23-11-2007	c71201: added meteo data, temperature model and powerstations
10.62	25-01-2008	c74229: differentiation in writing frequencies to SDS-file
10.63	31-01-2008	c77132: added 3D weirs
10.64	26-02-2008	m339237: changes in options CROSS_DERIV and ITERMOM
10.65	18-03-2008	m340758: remark not yet implemented added to sds_meteo and exp_meteo
10.66	01-04-2008	c78329: extension of the min/max functionality
10.67	08-04-2008	c68666: changed default for WGHTHALFTIME (disch-ad openings)
10.68	02-05-2008	c81402: included tidal forces
10.69	05-05-2008	m344228: improved documentation about TICVAL

10.70	22-05-2008	c81402:	changed input for tidal forces
10.71	16-06-2008	c82967:	added flag for automatic update of sill heights
10.72	30-07-2008	c78329:	changed keyword-settings for min/max functionality
10.73	17-09-2008	c84131:	extended capabilities of READ_FROM
10.74	22-09-2008	c81010:	added description for KALMAN_HISTORIES
10.75	23-09-2008	m355869:	clarification in HARMONIC_TIDE/OMEGA
10.76	28-10-2008	m358864:	correction in description of METH_DPS
10.77	14-11-2008	c85419:	introduced space varying viscosity
10.78	30-12-2008	c85904:	added array sizes ARRSIZM and ARRSIZN
10.79	07-01-2009	c84230:	coupling to wave model
10.80	04-02-2009	c85419:	introduced flag for old viscosity boundary condition
10.81	11-03-2009	c68934:	removed CLASS_LIMITS option
10.82	31-03-2009	c88002:	improvements for discharge boundaries
10.83	07-04-2009	c84230:	improvements for wave input
10.84	22-04-2009	c85420:	introduced parameter steered roughness codes
10.85	19-05-2009	c88481:	introduced default value for READ_FROM/-TIME_INITIAL
10.86	11-06-2009	c88648:	made subsections of FLOW/FORCINGS/-WAVES optional
10.87	08-07-2009	c91768:	small improvements
10.88	10-07-2009	c88719:	introduction of HLES
10.89	27-07-2009	m378003:	correction of TFRAMEITEROUTPUT
10.90	29-07-2009	c88719:	improvements in HLES section
10.91	30-07-2009	c91768:	made EXP_SVWP, EXP_INITIAL and EXP_RESTART optional
10.92	10-08-2009	c88481:	added keywords DALTON and STANTON to heat model
10.93	14-08-2009	c91583:	introduction of barrier-barrier structures
10.94	18-08-2009	c88481:	improved input for FRICOMBINATION
10.95	02-09-2009	c92281:	introduction of flexible barrier numbers
10.96	07-09-2009	c81107:	extensions for WEIRS, introduction VILLEMONTTE-model
10.97	14-10-2009	c81107:	corrected default value for CD_TWO
10.98	16-11-2009	c94153:	introduction of SPACE_VAR_WIND in HEAT-MODEL
10.99	08-12-2009	c94965:	diagnostic salt and temperature for density
10.100	09-03-2010	c1738:	new keyword LIMIT_VISC for HLES
10.101	10-03-2010	c3200:	changed def. value of Prandtl-Schmidt number to 0.7
10.102	11-03-2010	c3223:	clarified description of latitude and longitude
10.103	19-03-2010	c3194:	new keyword VERT_CHEZY

---

10.104	29-03-2010	c3228:	new keyword BOUND_OPTIONS
10.105	17-06-2010	c3256:	converted to $\LaTeX$
10.106	18-06-2010	c3256:	corrections after review of conversion
10.107	23-06-2010	c3346:	new keyword SKIP_PART
10.108	29-07-2010	c1767:	new keyword PRESGRAD
10.109	26-08-2010	c3207:	COOR_ID mandatory i.c.w. spacing varying wind and pressure
10.110	26-08-2010	m3388:	description of already existing keyword AD-VEC_SCHEME
10.111	29-09-2010	c3418:	Notes on the use of HLES and Initial-Velocities; empty name for points and curves will be filled with coordinates
10.112	18-10-2010	c3319:	support for barrier steering with locations in other domains
10.113	18-10-2010	c3438:	correction in BAR_SERIES w.r.t. relative time
10.114	02-11-2010	c3436:	Extra note in CONDITION for BARRIERS
10.115	14-03-2011	m3545:	Improved description of BAR_TIMES
10.116	03-05-2011	m3207:	Correction in dimensions of land-sea mask
10.117	23-05-2011	c3564:	Added FIXED_STATE to barrier steering
10.118	28-07-2011	c3585:	Copied description for KALMAN from other document and added OPENDA as an option
10.119	22-08-2011	c3585:	Corrections after review of version 10.118
10.120	17-11-2011	beheer:	Small corrections
10.121	07-12-2011	c3576:	Read LAND_SEA_MASK from windfile
10.122	29-12-2011	c3664:	Description of bubble screen definition
10.123	09-01-2012	c3677:	Options for writing wind and pressure fields to SDS
10.124	13-01-2012	m3334:	Compute velocities no longer very sensitive to round-off errors, but not supported for spherical models anymore.
10.125	07-03-2012	c3693:	Removed TIHLES; HLES is calculated every half time step between TFHLES and TLHLES.
10.126	21-05-2012	c3750:	Corrections in section KALMAN.
10.127	22-05-2012	c3750:	Small corrections.

# Contents

<b>1</b>	<b>The pre-processor waqpre</b>	<b>1</b>
<b>2</b>	<b>Input description</b>	<b>2</b>
2.1	General information . . . . .	2
2.1.1	Conventions used . . . . .	2
2.1.2	Data fields . . . . .	3
2.1.2.1	GLOBAL . . . . .	3
2.1.2.2	LOCAL . . . . .	5
2.1.3	Time series . . . . .	7
2.2	Main keywords . . . . .	8
2.3	IDENTIFICATION (mandatory) . . . . .	9
2.4	DEPTH_CONTROL (optional) . . . . .	10
2.4.1	ORIENTATION (mandatory) . . . . .	10
2.4.1.1	SILL_DEPTH (optional) . . . . .	10
2.5	RESTART (optional) . . . . .	12
2.6	MESH (mandatory) . . . . .	14
2.6.1	GRID (mandatory) . . . . .	14
2.6.1.1	AREA (mandatory) . . . . .	14
2.6.1.2	RECTILINEAR (optional) . . . . .	16
2.6.1.3	CURVILINEAR (optional) . . . . .	17
2.6.1.4	SPHERICAL (optional) . . . . .	17
2.6.1.5	GENERALIZED_SPHERICAL (optional) . . . . .	18
2.6.2	POINTS (mandatory) . . . . .	18
2.6.3	CURVES (optional) . . . . .	19
2.6.4	BOUNDARIES (optional) . . . . .	20
2.6.4.1	ENCLOSURES (optional) . . . . .	20

2.6.4.2	OPENINGS (optional) . . . . .	21
2.6.4.3	BARRIERS (optional) . . . . .	22
2.6.4.4	STRUCTURES (optional) . . . . .	24
2.6.5	BATHYMETRY (mandatory) . . . . .	24
2.6.5.1	GLOBAL (mandatory) . . . . .	25
2.6.5.2	LOCAL (optional) . . . . .	28
2.6.6	DRYPOINTS (optional) . . . . .	29
2.6.7	WEIRS (optional) . . . . .	29
2.6.8	VERTICAL (optional) . . . . .	34
2.6.9	POWERSTATIONS (optional) . . . . .	34
2.7	GENERAL (optional) . . . . .	36
2.7.1	DIFFUSION (optional) . . . . .	36
2.7.1.1	GLOBAL (mandatory) . . . . .	36
2.7.1.2	LOCAL (optional) . . . . .	37
2.7.2	PHYSICAL PARAMETERS (optional) . . . . .	37
2.7.3	WIND (optional) . . . . .	37
2.7.4	SPACE_VAR_WIND (optional) . . . . .	40
2.7.5	KALMAN (optional) . . . . .	44
2.7.5.1	STEADY_STATE . . . . .	44
2.7.5.2	RRSQRT . . . . .	45
2.7.5.3	OPENDA . . . . .	55
2.7.6	CORIOLIS (optional) . . . . .	64
2.7.6.1	GLOBAL (mandatory) . . . . .	64
2.7.6.2	LOCAL (optional) . . . . .	64
2.7.7	SPACE_DEP_CD (optional) . . . . .	65
2.7.8	SVWP_LS_MASK(optional) . . . . .	67
2.7.9	METEO_DATA (optional) . . . . .	68
2.7.9.1	AIR_TEMP . . . . .	70
2.7.9.2	HUMIDITY . . . . .	71
2.7.9.3	CLOUD_COVER . . . . .	71
2.7.9.4	SOLAR_IRRADIATION . . . . .	72
2.7.10	TIDAL_FORCES (optional) . . . . .	73
2.8	FLOW (mandatory) . . . . .	74
2.8.1	PROBLEM (mandatory) . . . . .	74



2.8.1.1	TIMEFRAME (mandatory)	74
2.8.1.2	METHODVARIABLES (mandatory)	75
2.8.1.3	SMOOTHING	79
2.8.1.4	DRYING (optional)	79
2.8.1.5	FRICITION (mandatory)	81
2.8.1.6	VISCOSITY (optional)	100
2.8.1.7	HOR_VISCOSITY (optional)	101
2.8.1.8	BARRIERCOEFFICIENTS (optional)	101
2.8.1.9	DISCHARGECOEFFICIENTS (optional)	102
2.8.1.10	WEIRS (optional)	105
2.8.1.11	VELOCITY_PROFILE	107
2.8.1.12	VERT_CHEZY	108
2.9	FORCINGS (optional)	109
2.9.1	Initial values, boundaries, barriers and waves	109
2.9.1.1	INITIAL (mandatory)	109
2.9.1.2	BOUNDARIES (optional)	112
2.9.1.3	TIMESERIES (optional)	115
2.9.1.4	FOURIER (optional)	116
2.9.1.5	HARMONIC (optional)	117
2.9.1.6	QHTABLES (optional)	118
2.9.1.7	DISCHARGES (optional)	118
2.9.1.8	BAR_TIMES (optional)	120
2.9.1.9	BARRIERS (optional)	120
2.9.1.10	BAR_SERIES (optional)	131
2.9.1.11	OBSERVATIONS (optional)	132
2.9.1.12	BAR_TABLES (optional)	136
2.9.1.13	WAVES (optional)	137
2.9.2	CHECKPOINTS (optional)	139
2.10	HYDRODYNAMIC (optional)	141
2.11	TRANSPORT (optional)	142
2.11.1	PROBLEM (mandatory)	142
2.11.1.1	CONSTITUENTS (optional)	142
2.11.1.2	SALINITY (optional)	143
2.11.1.3	TEMPERATURE (optional)	143

---

2.11.1.4	METHODVARIABLES (optional)	143
2.11.1.5	FALL_VELOCITIES (optional)	145
2.11.1.6	TURBULENCE_TRANS (optional)	145
2.11.2	FORCINGS (mandatory)	146
2.11.2.1	INITIAL (optional)	146
2.11.2.2	BOUNDARIES (optional)	149
2.11.2.3	DISCHARGES (optional)	151
2.11.2.4	POWERSTATIONS (optional)	152
2.11.3	CHECKPOINTS (optional)	153
2.11.4	USERDATA_TRANSPORT (optional)	153
2.11.4.1	CONTROL (mandatory)	154
2.11.4.2	REALS (optional)	154
2.11.4.3	INTEGERS (optional)	154
2.11.4.4	TIMEFUNCTIONS (optional)	155
2.11.4.5	INPUT_SPATIAL_DATA (optional)	156
2.11.4.6	TIME_DEPENDENT_DATA (optional)	157
2.11.4.7	OUTPUT_SPATIAL_DATA (optional)	159
2.12	DENSITY (optional)	160
2.13	DENSITIES (optional)	163
2.14	TURBULENCE_MODEL (optional)	164
2.14.1	WALL_DEFINITION (optional)	164
2.14.2	VERTVISCOSITY (optional)	164
2.14.2.1	CONSTANT (optional)	165
2.14.2.2	PARABOLIC (optional)	165
2.14.3	VERTDIFFUSION (optional)	166
2.14.3.1	CONSTANT (optional)	166
2.14.3.2	PARABOLIC (optional)	166
2.14.4	VERT_VARIANT (optional)	168
2.14.5	HOR_VARIANT (optional)	168
2.14.6	HLES (optional)	169
2.14.7	EMPIRICAL_CONSTANTS (optional)	170
2.15	HEATMODEL (optional)	174
2.15.1	HEATEXCHANGE (optional)	174
2.15.2	HEATBALANCE (optional)	175

2.15.2.1	LUDIKHUIZEN (optional)	175
2.15.2.2	DEGOEDE (optional)	175
2.15.3	SWEERS_WIND (optional)	176
2.15.4	BACK_TEMPERATURE (optional)	176
2.16	DISPLAYS (optional)	178
2.16.1	GRIDDISP (optional)	178
2.16.2	OUTLINES (optional)	178
2.16.2.1	GENERAL (optional)	179
2.16.2.2	LINES (optional)	179
2.16.3	TITLE (optional)	179
2.16.4	LEGEND (optional)	180
2.16.5	POSCLOCK (optional)	180
2.16.6	WINDARROW (optional)	181
2.16.7	PERMTITLES (optional)	182
2.16.8	ISOLINES (optional)	182
2.17	SDSOUTPUT (optional)	183
2.17.1	MAPS (optional)	184
2.17.2	HISTORIES (optional)	185
2.17.3	WEIR_HISTORIES (optional)	186
2.17.4	INTEGRATION (optional)	187
2.17.5	RESTART (optional)	188
2.17.6	HARMONIC_TIDE (optional)	188
2.17.6.1	SPKONE (optional)	189
2.17.6.2	SPNTWO (optional)	191
2.17.6.3	SPSTWO (optional)	193
2.17.6.4	SPTWOM (optional)	194
2.17.7	KALMAN_HISTORIES (optional)	196
2.17.8	CALCMAXVALUES (optional)	197
2.17.9	CALCMINVALUES (optional)	199
2.17.10	INCREMENTAL (optional)	201
2.18	PRINTOUTPUT (optional)	204
2.18.1	FLOW (optional)	204
2.18.2	TRANSPORT (optional)	205
2.18.3	CONTROL (optional)	205

2.19 Example input description for Roughcombination . . . . . 208

# Chapter 1

## The pre-processor waqpre

The user's guide Waqpre describes the content of the Simona Input file for Waqua and Triwaq, usually called "siminp". Waqua and Triwaq are respectively the 2D and 3D flow simulation programs within Simona. This document describes the keywords of the siminp, their order and their arguments. A more physical and numerical background can be found in the Technical Documentation of Waqua and Triwaq.

The program Waqpre is started using the Perl script waqpre.pl, with as one of the arguments the runid (run identification).

Waqpre is an abbreviation of "Waqua's preprocessor". First, Waqpre checks the siminp against the reference table, the formal description of the Waqpre-input. After that, more checks are performed to guarantee overall consistency. Finally, Waqpre writes the whole contents of the siminp in a binary format to the file SDS-<runid>. Warnings and errors are written to the file waqpre-m.<runid>. The user is suggested to read this message file carefully before starting the processor Waqpro.

# Chapter 2

## Input description

### 2.1 General information

The input is based on SIMONA keyword structure. Refer to “About SIMONA” in Section 1 “General Information”.

Reminder: The input file is a structured ASCII-file. From the input file only the first 258 columns are read.

Note: *If the last keyword block in the input file contains a sequential keyword, the SIMONA application independent preprocessor is not able to check the correctness of the block. This can result in incorrect processing of the input file!*

#### 2.1.1 Conventions used

For the input definition the following conventions are used:

- [val]* : real value
- [tval]* : time specification in the form: *day hours:minutes*  
(e.g. 2 21:15). Times are given relative to midnight of a reference date, starting at 0 0:00.
- [ival]* : integer value
- [iseq]* : sequence number to indicate a point, curve, etc.
- [text]* : string (enclosed between quotes)
- < ... > : repetition group
  
- | A  
< : choice between A and B (A and B are mutually exclusive)  
| B
  
- & : continuation mark

In this document a part of the keywords is underlined (e.g, PRINT-OUTPUT). Only the underlined characters are significant. So the user must type at least PRINT in his input, but PRINTOUT is excepted as well.

The 'Explanation' part of the description of the various sections, subsections is divided in three columns:

**Explanation:**

KEYWORD	E	Explanation
		E can be O, M, D, S, R, X
	O	means keyword is optional
	M	means keyword is mandatory
	D	means keyword has a default value. When this keyword is omitted, the pre-processor will use the default value for the variable specified by means of this keyword
	S	means this keyword is a sequential keyword: a keyword followed by an integer (e.g. P4). A sequential keyword can be used repeatedly
	R	means keyword may occur more than once
	X	Exactly one of a series of keywords should be given

## 2.1.2 Data fields

Data field input is to be specified in two blocks:

SPACE\_VARYING\_DATA  
GLOBAL  
LOCAL

SPACE\_VARYING\_DATA stands for any keyword representing spatial data. In GLOBAL the data for the complete field is to be given, specifying function values at all grid points. In LOCAL however the user can specify rectangular boxes in which he can change the value of the space varying data. For the case of 3D this definition is extended in such a way that the input for separate layers is possible.

### 2.1.2.1 GLOBAL

Global data can be specified in two ways: first by giving one value for the complete computational grid, second by giving values for each grid point. The order in which these values are to be given is specified by the layout flag.

GLOBAL  
LAYOUT = *[ival]*

```
| CONST_VALUE = [val]
<
| VARIABLE_VALUES = <[val]>
```

**Explanation:**

LAYOUT = [IVAL]

D Layout-indicator specifying the order in which the values from input file are assigned to the function value in a grid point. Possible values for LAYOUT and their meaning are: <sup>1</sup>

1. function values at grid points:  
 $[(m_1, n_1), (m_1, n_1 + 1) \dots (m_1, n_2)],$   
 $[(m_1 + 1, n_1) \dots (m_1 + 1, n_2)]$   
 $\dots [(m_2, n_1) \dots (m_2, n_2)]$   
 columns; first column is left; column values from bottom to top
2. function values at grid points:  
 $[(m_1, n_1), (m_1 + 1, n_1) \dots (m_2, n_1)],$   
 $[(m_1, n_1 + 1) \dots (m_2, n_1 + 1)]$   
 $\dots [(m_1, n_2) \dots (m_2, n_2)]$   
 rows; first row is bottom; row values from left to right
3. function values at grid points:  
 $[(m_2, n_1), (m_2, n_1 + 1) \dots (m_2, n_2)],$   
 $[(m_2 - 1, n_1) \dots (m_2 - 1, n_2)]$   
 $\dots [(m_1, n_1) \dots (m_1, n_2)]$   
 columns; first column is right; column values from bottom to top
4. function values at grid points:  
 $[(m_2, n_1), (m_2 - 1, n_1) \dots (m_1, n_1)],$   
 $[(m_2, n_1 + 1) \dots (m_1, n_1 + 1)]$   
 $\dots [(m_2, n_2) \dots (m_1, n_2)]$   
 rows; first row is bottom; row values from right to left

---

<sup>1</sup>Assume the limits of the box are given by  $(m_1, n_1)$  and  $(m_2, n_2)$  with  $m_1 \leq m_2$  and  $n_1 \leq n_2$ . In the case of global input  $n_1 = 1, n_2 = NMAX, m_1 = 1$  and  $m_2 = MMAX$ . The number of required function values is then  $n_{tot}m_{tot}$ , where :

$$n_{tot} = (\text{number of enclosed n grid points}) = n_2 - n_1 + 1$$

$$m_{tot} = (\text{number of enclosed m grid points}) = m_2 - m_1 + 1$$



5. function values at grid points:  
 $[(m_1, n_2), (m_1, n_2 - 1) \dots (m_1, n_1)],$   
 $[(m_1 + 1, n_2) \dots (m_1 + 1, n_1)]$   
 $\dots [(m_2, n_2) \dots (m_2, n_1)]$   
columns; first column is left; column values from top to bottom
6. function values at grid points:  
 $[(m_1, n_2), (m_1 + 1, n_2) \dots (m_2, n_2)],$   
 $[(m_1, n_2 - 1) \dots (m_2, n_2 - 1)]$   
 $\dots [(m_1, n_1) \dots (m_2, n_1)]$   
rows; first row is top; row values from left to right
7. function values at grid points:  
 $[(m_2, n_2), (m_2, n_2 - 1) \dots (m_2, n_1)],$   
 $[(m_2 - 1, n_2) \dots (m_2 - 1, n_1)]$   
 $\dots [(m_1, n_2) \dots (m_1, n_1)]$   
columns; first column is right; column values from top to bottom
8. function values at grid points:  
 $[(m_2, n_2), (m_2 - 1, n_2) \dots (m_1, n_2)],$   
 $[(m_2, n_2 - 1) \dots (m_1, n_2 - 1)]$   
 $\dots [(m_2, n_1) \dots (m_1, n_1)]$   
rows; first row is top; row values from right to left

Default = 1

CONST-VALUE = [VAL]

D Constant value for the complete field.

Default = 0

VARIABLE-VALUES =< [VAL] >

O It is possible to specify a function value at each grid point. The order in which the values are to be given is defined by means of layout-indicator.

In the case of 3D the information must be specified as a set of KMAX separate layers, each layer given according to the global layout-indicator (i.e. MMAX\*NMAX\*KMAX values must be specified, beginning with the top layer).

### 2.1.2.2 LOCAL

In LOCAL the function values at grid points specified in GLOBAL can locally be overwritten by specifying boxes (i.e. rectangles). In the 3D-case a box is a rectangle drawn in the horizontal plane identified by the layer-index.

LOCAL

< BOX : MNMX = ([ival],[ival])([ival],[ival])      LAYER = [ival]

```

| CONST_VALUES = [val]
<
| CORNER_VALUES = [val],[val],[val],[val]
<
| VARIABLE_VALUES = <[val]>
>

```

**Expansion: Explanation:**

BOX	R	<p>A BOX is defined by specifying its opposite corner points <math>(m1,n1)</math> and <math>(m2,n2)</math>, where <math>m1 \leq m2</math> and <math>n1 \leq n2</math>. In this rectangle the global function value of a “field” variable can be overwritten by new values. It is possible to define more than one box for one single “field” variable. When the rectangles defined in the boxes have common grid points, the latest values specified for those grid point will be used.</p> <p>The data can be specified either by means of a single value defining all points within the box or by means of a array of data. In the latter case the data should be given according to the following scheme:</p>
MNMN = ([IVAL], [IVAL]) ([IVAL], [IVAL])	M	<p>Corner points of the rectangular box, specifying <math>(m_1, n_1)(m_2, n_2)</math>, where <math>m_1 \leq m_2</math> and <math>n_1 \leq n_2</math>.</p>
LAYER = [IVAL]	O	<p>Layer index , where <math>0 \leq layer \leq kmax</math>. If layer is not specified or layer=0, a uniform vertical distribution is assumed. However, when the function values belong to a data-array which is defined for layers 0 until kmax, layer=0 is only valid for the upper layer and layer=-1 will define the uniform vertical distribution. As default, 3D-arrays are assumed to be defined for layers 1 until kmax, unless stated otherwise in their input description. LAYER is only relevant in the 3D-case.</p>
CONST_VALUES = [VAL]	O	<p>The function at all grid points in the box gets this value.</p>
CORNER_VALUES = [VAL][VAL][VAL][VAL]	O	<p>The function values at the corner points of the box are given in the following order <math>(m_1, n_1), (m_2, n_1), (m_2, n_2), (m_1, n_2)</math>. The function values at the other grid points enclosed by the box will be determined by means of bilinear interpolation.</p>

VARIABLE\_VALUES = < [VAL] >

- Inside the box for each grid point a function value is specified. The order in which the values are to be given is set by LAYOUT under keyword GLOBAL.

For example:

```
GLOBAL
  CONST_VALUES = 40.5
  LAYOUT = 4
LOCAL
  BOX: MNMN = (10, 5), (50,100)
  CONST_VALUES = 38
```

or

```
GLOBAL
  CONST_VALUES = 0
  LAYOUT = 3
LOCAL
  BOX: MNMN = (10, 5), (11,7)
  VARIABLE_VAL = 2 2.3 2.4 1.9 2.0 3.2
```

### 2.1.3 Time series

Time series are used for boundary conditions. There are two possibilities in SIMONA to specify time series: 'regular' and 'irregular'.

Regular time series are given by using a time frame (FRAME), defining a time first, time interval and time last (all times in minutes elapsed from midnight of the reference date as specified in FLOW, PROBLEM, TIMEFRAME, DATE). The values must be given at constant time intervals.

In case of irregular time series a time can be specified together with the values related to this time, repeatedly. In this case the times are given in day hour:minute. A minute can be specified with a decimal value (e.g. 5.75). In this notation midnight of the reference date as specified in FLOW, PROBLEM, TIMEFRAME, DATE is 0 0:00.

All time series are interpolated during computation.

'Timeseries' is not a (sub)keyword, but the name of an input structure that may be embedded in other keyword structures described in this guide. Initial values for time series must be specified (see paragraph 2.9.1.3).

Examples:

1. Timeseries

```
SERIES = 'REGULAR'
FRAME = 100. 5. 125.
VALUES = 5 6 7 7 3 4
```

## 2. Timeseries

```
SERIES = 'IRREGULAR'  
TIME_AND_VALUES = (0 1:00.5) 2  
TIME_AND_VALUES = (0 1:10.5) 8  
TIME_AND_VALUES = (0 2:00.5) 12
```

## 2.2 Main keywords

The input is divided in 14 main keywords. These keywords are (M = mandatory, O = optional):

DEPTH\_CONTROL (O)  
IDENTIFICATION (M)  
RESTART (O)  
MESH (M)  
GENERAL (O)  
FLOW (M)  
TRANSPORT (O)  
DENSITIES (O)  
DENSITY (O)  
TURBULENCE\_MODEL (O)  
DISPLAYS (O)  
SDSOUTPUT (O)  
PRINTOUTPUT (O)  
IGNORE (O)

These keywords are described in the following sections.

## 2.3 IDENTIFICATION (mandatory)

In the program identification block general information about the run is given. This section is mandatory.

### IDENTIFICATION

```
| WAQUA
<
| TRIWAQ
EXPERIMENT = [text]
OVERWRITE
MODID = [text]
TITLE = [text]
```

### Explanation:

WAQUA	X	Specifies the 2D SIMULATION MODE FOR FLOW AND TRANSPORT.
TRIWAQ	X	Specifies the 3D SIMULATION MODE FOR FLOW AND TRANSPORT.
EXPERIMENT = [text]	D	In [text] the name of the experiment is given. Maximum length of text is: 40 characters. Default: run identification (from command line).
OVERWRITE	D	When overwrite is specified, the experiment on the SDS FILE IS ALLOWED TO BE OVERWRITTEN. Default: no overwriting allowed.
MODID = [text]	O	In [text] the identification of the model is given for prints and plots. Maximum length = 72 characters.
TITLE = [text]	O	In [text] the title of the simulation is given (for prints and plots). Maximum length = 72 characters.

Notes: - The specification of the simulation mode (WAQUA or TRIWAQ) is required.

- In the current version of WAQPRE, ONLY ONE EXPERIMENT CAN BE WRITTEN TO AN SDS FILE; IF THE SPECIFIED SDS FILE ALREADY EXISTS, IT WILL ALWAYS BE OVERWRITTEN, EVEN WHEN OVERWRITE IS NOT SPECIFIED (DEFAULT).

## 2.4 DEPTH\_CONTROL (optional)

In this section the orientation of the depth input values should be specified.

The depth values which are orientation sensitive are:

- the depth values introduced under main keyword BATHYMETRY including special depth values THRESHOLD, TAGREPLACEMENT and DEPDEF;
- depth values U\_OVERFLOW\_HEIGHT and V\_OVERFLOW\_HEIGHT introduced under main keywords WEIRS.
- sill depth values introduced under keywords:
  - § 2.9.1.9 BARRIERS / B[*iseq*] / SILL\_DEPTH / (INITIAL and/or SERIES / (VALUES or TIME\_AND\_VALUES))
  - § 2.9.1.9 BARRIERS / B[*iseq*] / CONDITION (SILL-values used in conditions)
  - § 2.9.1.10 BAR\_SERIES / TS[*iseq*] / SILL / SERIES / (VALUES or TIME\_AND\_VALUES))
  - § 2.9.1.11 BAR\_TABLES / TB[*iseq*] / VALUES (first column)

### DEPTH\_CONTROL

ORIENTATION = [*text*]

SILL\_DEPTH = [*text*]

### 2.4.1 ORIENTATION (mandatory)

#### Explanation:

<u>ORIENTATION</u> = [ <i>text</i> ]	M	The orientation of the depth input. It may be either 'pos_downwards' or 'pos_upwards'.
--------------------------------------	---	--

The default value that is used when the entire section DEPTH\_CONTROL is absent is positive downwards in order to remain compatible with the past.

#### 2.4.1.1 SILL\_DEPTH (optional)

#### Explanation:

<u>SILL_DEPTH</u> = [ <i>text</i> ]	O	The orientation of the sill depth input. It may be either 'pos_downwards' or 'pos_upwards'.
-------------------------------------	---	---

If keyword SILL\_DEPTH is omitted or when the entire section DEPTH\_CONTROL is absent then the depth orientation for sill values will be positive downwards in order to remain compatible

with the past.

## 2.5 RESTART (optional)

The RESTART command states that the simulation is to be 'restarted' from the results of a previous WAQUA-experiment. The initial data passed to the WAQUA processor will be exactly the same as the data used in the simulation at the time level specified for restart, without any loss of information.

### RESTART

EXP\_RESTART = *[text]*

SDS\_RESTART = *[text]*

### Explanation:

EXP_RESTART	O	Name of the experiment with restart data.
SDS_RESTART	M	Name of the SDS file containing the restart data. The given file name can contain an explicit path name. The use of any indication of a parent directory ('..') is allowed.

Restart is only possible if:

- the reference date in the input file is greater than or equal to the reference date from the experiment in the SDS file;
- the restart data are available at the time level specified for TSTART;
- the fixed geometry (i.e. grid size, bathymetry, placing of boundaries, barriers, dry-points and weirs), as defined in section MESH has not been changed;
- both the current experiment and the restart experiment use the same simulation mode (WAQUA or TRIWAQ);
- the same combination flow/transport is used as in the current experiment: if the first run contains flow and transport, the restart run has to contain flow and transport; if the first run contains only flow, the restart run has to contain only flow.

- Notes:
- definition of initial condition, specified in section INITIAL will be ignored.
  - If some part of the fixed geometry has been changed (e.g. by adding or removing a dam point or adjusting bathymetry), command READ\_FROM (see subsection FORCINGS / INITIAL) should be used.
  - The initial values for the cumulative time-histories will be copied (if possible) using data of the previous experiment.
  - The possible difference between the restart date and the date on the SDS file will be accounted for.



- In the current version of WAQPRE, only one experiment can be written to an SDS file. If the specified SDS restart file is the same as the SDS file that is written to by WAQPRE, the contents of the SDS restart file will be lost.
- If `EXP_RESTART` is not specified, the first experiment on the specified SDS file will be taken.

## 2.6 MESH (mandatory)

In the mesh description the geometry of the model is defined.

### MESH

GRID

POINTS

CURVES

BOUNDARIES

BATHYMETRY

DRYPOINTS

WEIRS

VERTICAL

POWERSTATIONS

### 2.6.1 GRID (mandatory)

In subsection GRID information about the grid is given.

#### GRID

AREA (M)

RECTILINEAR (X)

CURVILINEAR (X)

SPHERICAL (X)

GENERALIZED\_SPHERICAL (X)

#### 2.6.1.1 AREA (mandatory)

In this subsection the grid and coordinate system used in the model will be defined.

##### AREA

MMAX = [ival]

NMAX = [ival]

KMAX = [ival]

ARRSIZM = [ival]

ARRSIZN = [ival]

ANGLEGRID = [val]

LATITUDE = [val]

LONGITUDE = [val]

COORD\_ID = [text]

**Explanation:**

---

MMAX = <i>[ival]</i>	M	Number of grid points in the M-dimension of the grid. In a rectilinear grid the M-direction is to the right.
NMAX = <i>[ival]</i>	M	Number of grid points in the N-dimension of the grid. In a rectilinear grid the N-direction is upward.
KMAX = <i>[ival]</i>	D	Number of layers (meaningful only in TRI-WAQ). Default = 1.
ARRSIZM = <i>[ival]</i>	O	Size of computational arrays in M-direction of the grid. When not given, ARRSIZM is set equal to MMAX. In some cases a larger value may result in higher performance.
ARRSIZN = <i>[ival]</i>	O	Size of computational arrays in N-direction of the grid. When not given, ARRSIZN is set equal to NMAX. In some cases a value larger than NMAX results in better performance.
ANGLEGRID = <i>[val]</i>	D	The angle between Y-axis (V-direction) and North (degrees). In general ANGLEGRID is the angle from the upward direction on maps rotating clockwise to the direction of the North direction arrow. For example, if the upwards direction of the Y-axis is West then <i>[val]</i> will be 90.
LATITUDE = <i>[val]</i>	D	Geographical position of the grid expressed in the latitude (degrees). Default = 51.5
LONGITUDE = <i>[val]</i>	D	Geographical position of the grid expressed in the longitude (degrees). Default = 0.
COOR_ID = <i>[text]</i>	D/M	Possible values:

- 0 = USER (User defined (= default value), undefined)
- 1 = INDEX (Model coordinates (M and N), undefined)
- 2 = RDV ("Rijksdriehoeksstelsel-verschoven", planar)
- 3 = ED50 (European Datum 1950, spherical)
- 4 = WGS84 (World Geodetic System 1984, spherical)
- 5 = UTM31 (Universal Transverse Mercator zone 31, planar)
- 6 = UTM32 (Universal Transverse Mercator zone 32, planar)
- 7 = GK (Gauss-Krüger coordinates, planar)

Maximum length = 24 characters.

Default: 'USER'; COOR\_ID is mandatory when using spacing varying wind and pressure.

Notes: - Latitude should be given in the grid-centre in the case of rectilinear or curvilinear grid.

Latitude should be given in the grid origin (water level grid point (1,1)) in the case of grid in spherical coordinates.

- Longitude should be given in the grid origin (water level grid point (1,1)) in the case of grid in spherical coordinates; it is not used when the computation is carried out on a "plain" grid.
- To retain compatibility with the previous versions of WAQPRE the items: XORIGIN, YORIGIN and STEPSIZE can be specified in this sub-section; in the current version they are moved to the subsection RECTILINEAR. If one of these items is specified both here and with RECTILINEAR, the specification in this subsection will be ignored.
- ANGLEGRID has no meaning in the case of a curvilinear grid.

### 2.6.1.2 RECTILINEAR (optional)

In this subsection the position of the grid-origin in general coordinate system and the spatial step used in the computation will be defined.

#### RECTILINEAR

XORIGIN = [val]  
YORIGIN = [val]  
STEPSIZE = [val]

**Explanation:**

XORIGIN = <i>[val]</i>	D	X-coordinate of the water level grid point (0,0). Default = 0.0
YORIGIN = <i>[val]</i>	D	Y-coordinate of the water level grid point (0,0). Default = 0.0
STEPSIZE = <i>[val]</i>	M	Distance between two adjacent grid points: spatial step size (m).

**2.6.1.3 CURVILINEAR (optional)**

In this subsection the name of the 'RGF' file must be given in the case of a curvilinear computation. In this case the information about the model description will be read from the so-called RGF file. The RGF file (generated by a grid generator) contains the x- and y-coordinates, that WAQPRE uses to calculate the coefficients of the orthogonal coordinate transformation.

CURVILINEAR

RGFFILE = *[text]*

**Explanation:**

RGFFILE = <i>[text]</i>	M	Name of the file with the x- and y-coordinates (the RGF file). The coordinate input may be given in two formats: '(10x, 5f12.0)' (single precision) or '(10x, 5d20.0)' (double precision)
-------------------------	---	--

**2.6.1.4 SPHERICAL (optional)**

In this subsection a special kind of the curvilinear grid is defined, that takes the spherical shape of the Earth.

SPHERICAL

STEPLAMBDA = *[val]*

STEPFI = *[val]*

RADIUS\_EARTH = *[val]*

**Explanation:**

STEPLAMBDA = [val]	D	Grid cell size in $\lambda$ -direction (degrees). Default: 1/8.
STEPFI = [val]	D	Grid cell size in $\phi$ -direction (degrees). Default: 1/12.
RADIUS_EARTH = [val]	D	Radius of the Earth (m). Default: 6.371*10 <sup>6</sup> .

Note: The  $\phi$ -direction coincides with the North-direction and the  $\lambda$ -direction coincides with the East-direction in the case anglegrid=0.

**2.6.1.5 GENERALIZED\_SPHERICAL (optional)**

In this subsection the name of the 'RGF' file must be given in the case of a curvilinear grid on a spherical surface (Generalized Spherical Coordinates (GSC)).

GENERALIZED\_SPHERICALRGFFILE = [text]RADIUS\_EARTH = [val]**Explanation:**

RGFFILE = [text]	M	Name of the file with the x- and y-coordinates (the RGF file). The coordinate input may be given in two formats: '(10x, 5f12.0)' (single precision) or '(10x, 5d20.0)' (double precision)
RADIUS_EARTH = [val]	D	Radius of the Earth (m). Default: 6.371*10 <sup>6</sup> .

Note: Due to the vast circumference of the earth the user should take into account that the coordinates need high accuracy or else the rounding errors at the calculation of the cell faces will be too large. In other words, the double precision RGF-input format should be used when there are cells smaller than kilometers.

**2.6.2 POINTS (mandatory)**

In this subsection user points can be defined. The user points can be used in several parts of the input (definition of barriers, openings, discharges, checkpoints, forcings at openings). In this way it is possible to refer to a grid point location by for example P8 in stead of (456,

821).

In addition a name can be assigned to a point. This name can be used for post-processing purposes, but also as a reference in the input file: by giving a point a meaningful name it is possible for the user to recollect the purpose of the user point he has defined.

If the name is left empty, it will be filled with the coordinates.

#### POINTS

<P [*iseq*]: ( M = [*ival*]      N = [*ival*]      NAME = [*text*] ) >

#### **Explanation:**

P = [ <i>iseq</i> ]	S	Point with sequence number.
M = [ <i>ival</i> ]	M	M-coordinate of point [ <i>iseq</i> ]
N = [ <i>ival</i> ]	M	N-coordinate of point [ <i>iseq</i> ]
NAME = [ <i>text</i> ]	O	Name of point, is used for print and plot output. Maximum length of name = 20 characters

### 2.6.3 CURVES (optional)

In this subsection user curves can be defined. User curves can be used in several parts of the input. In this way in the input it is possible to refer to a curve by C45. At this moment only straight lines are defined as user curves. See for example section FLOW, CHECKPOINTS (2.9.2).

As in points it is possible to assign a name to a curve. If the name is left empty, it will be filled with the begin and end coordinates.

#### CURVES

<C [*iseq*]:      LINE ( P = [*iseq1*]      P = [*iseq2*]      NAME = [*text*] ) >

#### **Explanation:**

C [ <i>iseq</i> ]	S	Curve with sequence number.
LINE	M	Type of curve (only LINE is implemented).
P [ <i>iseq1</i> ]	M	Start point of line [ <i>iseq</i> ].
P [ <i>iseq1</i> ]	M	End point of line [ <i>iseq</i> ].
NAME = [ <i>text</i> ]	O	Name of curve, is used for print and plot output. Maximum length of name = 20 characters.

## 2.6.4 BOUNDARIES (optional)

In this subsection information about the boundaries will be given. A barrier is considered to be an internal boundary.

### BOUNDARIES

ENCLOSURES

OPENINGS

BARRIERS

### 2.6.4.1 ENCLOSURES (optional)

In this subsection enclosures of the computational grid are defined. By using enclosures a computational grid may be defined within the rectangular grid defined by MMAX, NMAX. The purpose is to limit the computation to those grid points which are potentially flooded.

An enclosure definition is a polygon and consists of a sequence of (m, n)-coordinates. Between two subsequent points a line is drawn. These lines can be placed horizontally, vertically or under an angle of 45 relative to the computational grid. The last coordinate pair must be equal to the first coordinate pair.

If the full grid rectangle is to be computed in the simulation, then no enclosure definition is given here. In this case, the effective computational rows and columns are  $m = 2$  to  $MMAX-1$  and  $n = 2$  to  $NMAX-1$ . In effect, WAQPRE will generate a default computational grid enclosure through the grid points (1,1), (1,NMAX), (MMAX,NMAX), (MMAX,1) & (1,1). In this case, tide openings will be located along one or more of these: the rows  $m = 1$  and  $m = MMAX$ ; and the columns  $n = 1$  and  $n = NMAX$ . Note that the enclosure and the tide openings are superimposed. The points of the computational grid enclosure are not included in the computational field.

### ENCLOSURES

<E :      COORDINATES = < ([ival1],[ival2]) > >

### **Explanation:**

E	R	Each enclosure definition must start with keyword E.
COORDINATES = < ([ival1],[ival2]) >	M	Sequence of (m,n)-coordinates.

Notes: - It is desirable to place large open boundaries at the outside of the grid matrix. In that case, on the lines just inside the edge, the advection terms are completely omitted in the computation of motion. If the boundary is not in the border of the rectangular grid, then the advection terms for points just inside the boundary are not completely omitted, and they may introduce boundary instabilities if the boundaries are long.



However, tide measurements may have been collected at geographic points which are not along perpendicular straight lines. Since the enclosure of the computational grid must correspond to the locations of the tide openings, a non-rectangular computational grid may be required. Also, where the shape of the water body is not nearly rectangular, computational time can be saved by describing a computational grid that more nearly fits the body of water.

- Open boundaries lie just outside the computational grid. Long open boundaries should be at the edge of the rectangular grid as well.
- The following must lie inside the computational grid: sources of discharge, constituent checkpoints, barriers or sluices, permanently dry points or dams (ineffective if outside).
- Water level stations can be inside the computational grid or on a water level open boundary.

- Limitations:
- The computational grid may be defined by one or several computational grid enclosures of arbitrary shape. Each enclosure is a closed figure or polygon which defines an outer edge, or an inner edge around an island. An enclosure is given as a set of M,N grid points where adjacent points define straight line segments, and the first point coincides with the last point. No redundant points are given, rather every point given is a “corner” where the following line segment is not a straight-line continuation of the previous line segment. Line segments may be horizontal or vertical with respect to the grid, or they may be diagonals at multiples of 45 degrees.
  - Although an enclosure polygon defining an island may be wholly contained within another enclosure polygon, they should not cross or coincide. Parallel line segments may not be adjacent; that is, at least one M row or N column must fall between them, if the area between them is “inside”. Similarly, all inner and outer angles formed by consecutive line segments must be at least 90 degrees. A line segment must be at least two grid spaces long, if the following line segment reverses the direction of the previous segment.

#### 2.6.4.2 OPENINGS (optional)

In this subsection open boundaries are specified. The definition of these open boundaries can be used in the FLOW and TRANSPORT sections of the model description

##### OPENINGS

```
<OPEN [iseq]:      LINE ( P =[iseq1]      P =[iseq2]      NAME =[text] ) >
```

##### **Explanation:**

OPEN = [iseq]	S	Opening sequence number.
LINE	M	Type of opening curve. (Only line is implemented.)

P [ <i>iseq1</i> ]	M	Start point of opening [ <i>iseq</i> ].
P [ <i>iseq2</i> ]	M	End point of opening [ <i>iseq</i> ].
NAME = [ <i>text</i> ]	O	Name of opening [ <i>iseq</i> ], is used for print and plot output. Maximum length of name = 20 characters.

Limitations: - Open boundaries lie just outside the computational grid. Long open boundaries should be at the edge of the rectangular grid as well. The default computational grid, if none is explicitly given, extends from M=2 through M=MMAX-1 and from N=2 through N=Nmax-1. In this case, a tide opening falls on one of the four lines M=1, M=MMAX, N=1 or N=NMAX, except for velocity openings above or to the right, which fall on the M=MMAX-1 or N=NMAX-1 lines.

The reason for the exceptions is that in the space-staggered grid the velocity points are already above and to the right of the water level grid point with the same M,N index.

- In a grid-point only one opening type is allowed. This means that a U- and V-velocity opening cannot begin or end at the same grid point.
- In general, the open boundaries feed into the computational grid from just outside. This also implies that the ends of an open boundary do not extend beyond the grid. For example, an opening on the N=1 line would fall within the range M=2 through M=MMAX-1.
- If an open boundary is long, then it should be placed at the edge of the rectangular grid (and the computational grid chosen to correspond, of course).
- Openings are not allowed to overlap. Therefore a point (m,n) lying inside one opening is not allowed to be part of any other opening. Begin and end points of openings can be shared.

Note: The numbering sequence (*iseq*) of the openings may be in random order, and gaps between the numbers are allowed.

### 2.6.4.3 BARRIERS (optional)

In this section the barriers are specified. The barrier computation in the simulation program permits computation through an opening in a dam. The barriers are situated in the velocity points and so the flow can be in the U or V direction. If a U barrier is at an U-velocity point M,N, then the computation takes water out of water level point M and discharges it at M+1, if the water level is higher than at M+1.

A point barrier can be defined in the M- and N grid directions, but also diagonal point barriers are possible.

It is also possible to define barriers to be located along a line. A line barrier can only be defined along a grid line (thus the M-coordinate or the N-coordinate must be constant). During the computation line barriers will be converted into point barriers.

More information on barriers can be found in § 3.5.1, Barriers and sluices, of the User's Guide WAQUA: general information.

See also Technical report TR05-03, "Niet aansluitende overgangen tussen verschillende toestanden van barriers in WAQUA", dr.ir. E.A.H. Vollebregt (VORtech Computing).

See also § 2.8, Barriers and sluices, of WAQUA/TRIWAQ two- and threedimensional shallow water flow model, Technical documentation (SIMONA report 99-01).

See also 'Vernieuwing kunstwerkformulering in WAQUA', eindrapport ontwikkeling prototype, technisch rapport BvP/1383/6697, 1 december 2006).

#### BARRIERS

```

B [iseq]
  | P [iseq1]
  |   TYPE = [text]
  |   DIAG = [ival]
  <
  | C [iseq1]

```

#### **Explanation:**

B [ <i>iseq</i> ]	S	Each definition of a barrier must begin with keyword B and a sequence number for the barrier.
P [ <i>iseq1</i> ]	M	Position of barrier, [ <i>iseq1</i> ] is the sequence number of the user point as defined in MESH, POINTS.
TYPE = [ <i>text</i> ]	M	Barrier type possible values: 'u-bar' or 'u_bar' indicating barrier is a u-barrier. 'v-bar' or 'v_bar' indicating barrier is a v-barrier.
DIAG = [ <i>ival</i> ]	D	Is used to define the orientation of the barrier. Possible values for DIAG are: 0 : perpendicular, 1 : from left upper to right under, 2 : from left under to right upper. Default = 0.
C [ <i>iseq1</i> ]	S	Position of barrier, [ <i>iseq1</i> ] is the sequence number of the curve as defined in MESH, CURVES.

Limitations: - In TRIWAQ only (gate restricting) subcritical flow can be considered.

- Barriers must be at least  $2\frac{1}{2}$  grid spaces in the constricted direction away from:

- 1) dams,
- 2) other barriers,
- 3) computational grid enclosures.

However, barriers may be diagonally adjacent to the above. Also, a U-barrier and a V-barrier may be at the same grid point.

#### 2.6.4.4 STRUCTURES (optional)

In this section, barrier-barrier structures are specified. Barrier-barrier structures are hydraulic structures which are more complicated than the barrier input can describe. Such structures are described as the combination of two barriers. Two types of such structures are supported: the combination of a culvert and a weir, and intakes.

##### STRUCTURES

CULVERT\_AND\_WEIR :

<B [*iseq1*][*iseq2*]>

INTAKE :

<B [*iseq1*][*iseq2*]>

#### Explanation:

CULVERT_AND_WEIR	O	The culvert and weir combinations are specified under this keyword.
INTAKE	O	The intake combinations are specified under this keyword.
B [ <i>iseq1</i> ][ <i>iseq2</i> ]	M	Sequence numbers of the two barriers that form the structure.

#### 2.6.5 BATHYMETRY (mandatory)

In this subsection the bottom level with respect to datum reference level of the model is defined.

The orientation of the values depends on the value of keyword ORIENTATION (Section 2.4.1). By default, the orientation is positive downwards.

At first, the depth value in all points is set to zero. Next, these values may be overwritten by global and/or local data fields, which are described below.

##### BATHYMETRY

GLOBAL

LOCAL

### 2.6.5.1 GLOBAL (mandatory)

There are three ways to specify depths (meters):

1. depth can be specified by a constant value for the computational area (by using keyword `CONST_VALUE`); the given values will optionally be adapted by specifying `DEPMULTIPL` and `THRESHOLD`,
2. by giving values for each grid point (keyword `VARIABLE_VALUES`), where values equal to the `DEPTAG`-value will be replaced by the `TAGREPL`-value (this is one possibility to define dry points), after which adaptations will be made according to the given values for `DEPMULTIPL` and `THRESHOLD`,
3. in the traditional `WAQUA`-way by giving depth values for each grid point (keyword `VARIABLE_VALUES`), where also values greater than `THRESHOLD` are multiplied by `DEPMULTIPL`, after which values equal to 0 will be replaced by the `DEPDEF` value.

*How to specify the bathymetry?*

In the past depth values could only be specified in so-called depth corner points, which are located at the right upper corner of computational cells (see for example Fig. 3.4). In order to improve the drying and flooding possibilities an option has been added to define depth values in water elevation points, which are located in the centre of the computational cells. These two options will be explained below (see keywords `DPD_GIVEN` or `DPS_GIVEN`).

In case of the old option of depth values in depth points (`DPD_GIVEN`) keyword `METH_DPS` can be used to specify the various options for the computation of the depth values at water level points. In case of the new option of depth values in water level points (`DPS_GIVEN`) keyword `METH_DPS` is no longer required, because the depth values in water level points are already specified on input.

For the computation of depth values in velocity points a new keyword has been added, namely `METH_DPUV`. For this keyword there are four options, of which one of them (namely `MEAN_DPD`) corresponds to the only option that was possible in the past.

See also: Memo EV/M04.100, 2004

Erik de Goede (WL | Delft Hydraulics), Edwin Vollebregt and Bas van 't Hof (VORtech Computing).

#### GLOBAL

```

DEPMULTIPL = [val]
THRESHOLD = [val]
| DPD_GIVEN
<
| DPS_GIVEN
METH_DPS = 'MIN_DPUV' | 'MEAN_DPD' | 'MAX_DPUV' | 'MAX_DPD'
METH_DPUV = 'MIN_DPS' | 'MEAN_DPS' | 'MAX_DPS' | 'MEAN_DPD'
LAYOUT = [ival]
| CONST_VALUES = [val]

```

```

<
| DEPTAG = [val]      TAGREPLACEMENT = [val]
|   VARIABLE_VALUES = <[val]>
<
| DEPDEF = [val]
|   VARIABLE_VALUES = <[val]>

```

**Explanation:**

- |                             |   |  |
|-----------------------------|---|--|
| CONST_VALUES = [val]        | D | See paragraph 2.1.2.1 (m)<br>Default = 0.0   |
| VARIABLE_VALUES = < [val] > | O | See paragraph 2.1.2.1 (m)  |
| DPD_GIVEN                   | O | Flag: Depth values are specified in so-called depth points, see also DPS_GIVEN.  |
| DPS_GIVEN                   | O | Flag: Depth values are specified in so-called water level points.<br>Note: this flag is mutually exclusive with flag DPD_GIVEN. When neither of these are specified DPD_GIVEN is the default option.   |
| METH_DPS = [text]           | D | Flag for selection of the drying/flooding procedure for the computation of depth values in water level points. Note that the METH_DPS parameter can only be used in combination with DPD_GIVEN. In case of DPS_GIVEN the depth values in water level points are already specified on input and have not to be computed. When the depth values are specified in depth points, then the following four options are available for the computation of the local depths at water level points:<br>‘MAX_DPUV’: a ‘maximum criterion’<br>‘MEAN_DPD’: a ‘mean criterion’.<br>‘MIN_DPUV’: a ‘minimum criterion’ (Leendertselike).<br>‘MAX_DPD’: a ‘maximum criterion’ that is different from option ‘MAX_DPUV’. For a detailed description we refer to section 3.6.2 in the general part of the Users Guide WAQUA.<br>Default: ‘MAX_DPUV’ |

- Notes:
- The algorithm for determining the depths in water level points is based on a positive downwards orientation (e.g. the maximum operation results into the deepest depth value). N.B. This can be applied as well in combination with a bathymetry that uses a positive upwards orientation.
  - The above replace all options of old keyword IDRYFLAG, which is no longer in use (see section 2.8.1.4). This is explained in detail in Section 3.6.2 in the general part of the Users Guide WAQUA.
  - If keyword DPS\_GIVEN is used, then METH\_DPS should not be used. In this case a warning is generated:

**WARNING:**

keyword METH\_DPS should not be used in combination with DPS\_GIVEN and the keyword is neglected.

METH.DPUV = *[text]*

D

Flag for selection of the drying/flooding procedure for the computation of depth values in velocity points. Possible options are:

‘MIN\_DPS’: minimum depth value of the (two) neighbouring water level points.

‘MEAN\_DPS’: average depth value of the (two) neighbouring water level points

‘MAX\_DPS’: maximum depth value of the (two) neighbouring water level points

‘MEAN\_DPD’: average depth value of the (two) neighbouring depth points.

Default: ‘MEAN\_DPD’ in case of DPD\_GIVEN and ‘MIN\_DPS’ in case of DPS\_GIVEN.

**Note:** The combination ‘MIN\_DPU’ and DPD\_GIVEN is allowed as well and results into a tiled depth approach.

**Note:** The algorithm for determining the depths in velocity points is based on a positive downwards orientation (e.g. the minimum operation results into the most shallow depth value). N.B. This can be applied as well in combination with a bathymetry that uses a positive upwards orientation.

LAYOUT = *[ival]*

D

See paragraph 2.1.2.1

Default = 1

DEPMULTIPL = <i>[val]</i>	D	Can be used, together with THRESHOLD, to perform sensitivity analysis of the computation due to variation in depth. When DEPMULTIPL is not equal to 1.0 all depth values greater than the threshold value specified in THRESHOLD will be multiplied by the DEPMULTIPL-value. Default = 1.0
THRESHOLD = <i>[val]</i>	D	Threshold depth (see also description of DEPMULTIPL). (m) Default = 0.0
DEPTAG = <i>[val]</i>	O	For all grid points with a depth value DEPTAG, its value will be replaced by TAGREPLACEMENT.
TAGREPLACEMENT = <i>[val]</i>	O	See DEPTAG.
DEPDEF = <i>[val]</i>	O	For all grid points with a depth value of zero, its value will be set to -DEPDEF. (m)

### 2.6.5.2 LOCAL (optional)

In LOCAL the function values for depths at grid points specified in GLOBAL can locally be overwritten by specifying boxes.

Note: First all values in LOCAL are set, then the processes DEPTAG and DEPDEF as described in GLOBAL are executed.

#### LOCAL

```

<   BOX : MNMN = ([ival],[ival])([ival],[ival])   LAYER = [ival]
      | CONST_VALUES = [val]
      <
      | CORNER_VALUES = [val],[val],[val],[val]
      <
      | VARIABLE_VALUES = <[val]>
>

```

#### Explanation:

BOX	R	See paragraph 2.1.2.1
MNMN = ( <i>[ival], [ival]</i> ) ( <i>[ival], [ival]</i> )	M	See paragraph 2.1.2.1
CONST_VALUES = <i>[val]</i>	O	See paragraph 2.1.2.1 (m)
CORNER_VALUES = <i>[val],[val],[val],[val]</i>	O	See paragraph 2.1.2.1 (m)
VARIABLE_VALUES = < <i>[val]</i> >	O	See paragraph 2.1.2.1 (m)



## 2.6.6 DRYPOINTS (optional)

In this subsection screens and dam points can be defined.

### DRYPOINTS

#### DAMPOINTS

<COORDINATES : DAMCOOR = < ([ival1],[ival2])> >

#### CLOSEU

<MNN : MNNLINE = ([ival1],[ival2],[ival3]) >

#### CLOSEV

<NMM : NMMLINE = ([ival1],[ival2],[ival3]) >

### Explanation:

<u>COORDINATES:DAMCOOR</u> = < ([ival1],[ival2]) >	M	Point (M,N) ([ival1],[ival2]) is a dam point or in other words a permanent dry water level point.
<u>MNN:MNNLINE</u> = ([ival1],[ival2],[ival3])	M	A screen perpendicular to the U-direction is defined by one M-coordinate [ival1] and two N-coordinates [ival2] and [ival3]. This screen starts at ([ival1], [ival2]) and ends at ([ival1],[ival3])
<u>NMM:NMMLINE</u> = ([ival1],[ival2],[ival3])	M	A screen perpendicular to the V-direction is defined by one N-coordinate [ival1] and two M-coordinates [ival2] and [ival3]. This screen starts at ([ival2], [ival1]) and ends at ([ival3],[ival1]).

## 2.6.7 WEIRS (optional)

In this section it is possible to define weirs in the model. Models containing weirs may contain large numbers of weirs, because of this reason the location of the weirs are defined by specifying the M and N coordinates of the grid point and not by using user points.

### WEIRS

<W : M [ival]  
N [ival]  
U\_OVERFLOW\_HEIGHT [val]  
U\_SILL\_UP [val]  
U\_SILL\_DOWN [val]  
V\_OVERFLOW\_HEIGHT [val]  
V\_SILL\_UP [val]  
V\_SILL\_DOWN [val]  
U\_GROYNE [text]  
V\_GROYNE [text]

```

U_TYPE [ival]
V_TYPE [ival]
U_CREST_LENGTH [val]
U_TALUD_UP [val]
U_TALUD_DOWN [val]
V_CREST_LENGTH [val]
V_TALUD_UP [val]
V_TALUD_DOWN [val]
VEGETATION_CODE [ival]
CD_ONE [val]
CD_TWO [val]>

```

### Explanation:

<p>w</p> <p>M = [ival]</p> <p>N = [ival]</p> <p>U_OVERFLOW_HEIGHT = [val]</p>         <p>U_SILL_UP = [val]</p>	<p>R</p> <p>M</p> <p>M</p> <p>O</p> <p>O</p>	<p>Each weir definition must start with this keyword</p> <p>M-coordinate of the weir.</p> <p>N-coordinate of the weir.</p> <p>Overflow height of the U-weir with coordinates (M, N) in meters (m) with respect to reference level. Just like the bottom level (keyword: BATHYMETRY) the overflow height has to be given positive downwards. This means that weirs above the reference level have a negative value and weirs below reference level have a positive value. If in this point no U-weir exists this keyword has no meaning. If however a U-weir exist in this point this keyword is mandatory.</p> <p>Sill-height of the U-weir in meters (m) with coordinates M,N in the direction where M increases. This is the distance between the top of the weir and the bottom (depth - overflow-height) and therefore always has to be positive.</p> <p>When the flag AUTO_SILL_HEIGHT is true or the value given here is equal to -99.00, then the sill-depth will be derived from the overflow-height given above and the local bottom depth at the upper side of the weir. If in this point no U-weir exists this keyword has no meaning. If however a U-weir exist in this point this keyword is mandatory.</p>
---	--	--

- 
- |  |   |   |
|--|---|---|
| <code>U_SILL_DOWN = [val]</code>       | O | Sill-height of the U-weir with coordinates M,N in the direction where M decreases. For its values and the meaning of these values see U_SILL_UP above.  |
| <code>V_OVERFLOW_HEIGHT = [val]</code> | O | Overflow-height of the V-weir with coordinates M,N, in meters (m) with respect to datum reference level. Just like the depth, this has to be given positive downward, which means that weirs above reference level have a negative value and weirs below reference level have a positive value.<br>If in this point no V-weir exists this keyword has no meaning. If however a V-weir exist in this point this keyword is mandatory.  |
| <code>V_SILL_UP = [val]</code>         | O | Sill-height of the V-weir with coordinates M,N in the direction where N increases. This is the distance between the top of the weir and the bottom (depth - overflow-height) and therefore always has to be positive.<br>When the flag AUTO_SILL_HEIGHT is true or the value given here is equal to -99.00, then the sill-depth will be derived from the overflow-height given above and the local bottom depth at the upper side of the weir.<br>If in this point no V-weir exists this keyword has no meaning. If however a V-weir exist in this point this keyword is mandatory. |
| <code>V_SILL_DOWN = [val]</code>       | O | Sill-height of the V-weir with coordinates M,N in the direction where N decreases. For its values and the meaning of these values see V_SILL_UP above.<br>If in this point no V-weir exists this keyword has no meaning. If however a V-weir exist in this point this keyword is mandatory.   |
| <code>U_GROYNE = [text]</code>         | O | U_GROYNE = 'K ' means that the U-weir with coordinates M,N is a groyne, and a blank means that this U-weir is not a groyne.<br>If in this point no U-weir exists this keyword has no meaning. If however a V-weir exist in this point this keyword is mandatory.  |
| <code>V_GROYNE = [text]</code>         | O | v_GROYNE = 'K ' means that the V-weir with coordinates M,N is a groyne, and a blank means that this V-weir is not a groyne.<br>If in this point no V-weir exists this keyword has no meaning. If however a V-weir exist in this point this keyword is mandatory.  |

U\_TYPE = [ival]

- O Type of U-weir.  
There are six possibilities:
  - 0 : Means no U-weir with coordinates M,N.
  - 1 : Means a vertical U-weir with coordinates M,N.
  - 3 : Means a diagonal U-weir of type 3 with coordinates M,N. This U-weir has to be combined with a V-weir of type 3 with coordinates M+1,N-1.
  - 4 : Means a diagonal U-weir of type 4 with coordinates M,N. This U-weir has to be combined with a V-weir of type 4 with coordinates M,N-1.
  - 5 : Means a diagonal U-weir of type 5 with coordinates M,N. This U-weir has to be combined with a V-weir of type 5 with coordinates M,N.
  - 6 : Means a diagonal U-weir of type 6 with coordinates M,N. This U-weir has to be combined with a V-weir of type 6 with coordinates M+1,N

V\_TYPE = [ival]

- O Type of V-weir.  
There are six possibilities:
  - 0 : Means no V-weir with coordinates M,N.
  - 2 : Means a horizontal V-weir with coordinates M,N.
  - 3 : Means a diagonal V-weir of type 3 with coordinates M,N. This V-weir has to be combined with a U-weir of type 3 with coordinates M-1,N+1.
  - 4 : Means a diagonal V-weir of type 4 with coordinates M,N. This V-weir has to be combined with a U-weir of type 4 with coordinates M,N+1.
  - 5 : Means a diagonal V-weir of type 5 with coordinates M,N. This V-weir has to be combined with a U-weir of type 5 with coordinates M,N.
  - 6 : Means a diagonal V-weir of type 6 with coordinates M,N. This V-weir has to be combined with a U-weir of type 6 with coordinates M-1,N

U\_CREAST\_LENGTH = [val]

- D Length of the weir's crest (in the direction across the weir).

		Default: 3.0m.
U_TALUD_UP = [val]	D	Ramp (length/height) of the slope from the weir in the direction where M decreases. Default: 4.0 (ratio length : height = 4:1).
U_TALUD_DOWN = [val]	D	Ramp (length/height) of the slope from the weir in the direction where M increases. Default: 4.0 (ratio length : height = 4:1).
V_CREST_LENGTH = [val]	D	Length of the weir's crest (in the direction across the weir). Default: 3.0m.
V_TALUD_UP = [val]	D	Ramp (length/height) of the slope from the weir in the direction where N decreases. Default: 4.0 (ratio length : height = 4:1).
V_TALUD_DOWN = [val]	D	Ramp (length/height) of the slope from the weir in the direction where N increases. Default: 4.0 (ratio length : height = 4:1).
VEGETATION_CODE = [ival]	D	Type of vegetation of the U- or V-weir (-). This integer number corresponds to a vegetation file that is used for keyword ROUGH_CHAR in the ROUGHCOMBINATION block for friction.
CD_ONE = [val]	D	First calibration coefficient in the Villemonte model (-). Default: 1.0. Larger values cause the energy loss to decrease. NB: recent measurements (Bloemberg data set) were matched with the value CD_ONE = 0.8, which is less than the default.
CD_TWO = [val]	D	Second calibration coefficient in the Villemonte model (-). Default: 10.0. Larger values cause the energy loss to decrease. NB: recent measurements (Bloemberg data set) were matched with the value CD_TWO = 50.0, which is more than the default.

- Notes: - The use of weirs near boundaries and in combination with screens deserves extra attention. If a straight weir is defined at the same place as a permanent screen, the weir will be taken out of the computation. If one part of a diagonal weir is defined at the same place as a permanent screen, that part of the weir will be taken out of the computation. If the remaining part of the weir is also defined at the same place as a permanent screen, that part will also be taken out of the computation, otherwise that part will be changed in a vertical (U-weir) or horizontal (V-weir) weir respectively.
- Weirs are not available in simulations in which the 'Z0-based' bottom friction method (see section 2.8.1.5, GLOBAL / FORMULA) is used.

- The keywords U\_CREST\_LENGTH, U\_TALUD\_UP, U\_TALUD\_DOWN, V\_CREST\_LENGTH, V\_TALUD\_UP, V\_TALUD\_DOWN, CD\_ONE and CD\_TWO only have an effect when using the VILLEMONTTE model for weirs (see keyword FLOW/PROBLEM/WEIRS/VILLEMONTTE).

### 2.6.8 VERTICAL (optional)

In this section the information over the vertical discretisation (i.e. layers' thicknesses) can be given.

#### VERTICAL

```
<      | LAYER = [ival]: THICKNESS = [val] PERC
<
      | LAYER = [ival]: THICKNESS = [val] M
>
```

#### **Explanation:**

LAYER = [ival]	M	Layer index ( $1 \leq \text{layer} \leq \text{KMAX}$ ).
THICKNESS = [val]	M	Layer thickness (in meters or as percentage of variable layers)
PERC[val]	O	Flag: thickness given as percentage; implies that this layer has a variable thickness
M[val]	O	Flag: thickness given meters: implies that this layer has a fixed thickness.

Notes: - The layer information is only relevant for triwaq.

- If no layer information is found in the input, the equidistant layer-distribution will be used (i.e. all layers will have variable thickness equal to total depth divided by KMAX).
- The sum of layer-thicknesses defined as percentages must be 100.
- At least one layer with variable thickness must be defined.
- The layers are counted from top to bottom, i.e. the top layer has the index=1 and the bottom layer has the index=KMAX.
- The specification of either M or PERC is required.

### 2.6.9 POWERSTATIONS (optional)

In this section the information over powerstations can be given. This are coupled discharge-points, for instance meant for modeling of energy plants that take in water at one point,

use it for cooling of the plant, and dispose of the water at another location. The discharge for a powerstation is specified under FLOW – FORCINGS – DISCHARGES (see section 2.9.1.7), the effect on transported constituents is specified under TRANSPORT – FORCINGS – POWERSTATIONS (see section ).

**POWERSTATIONS**

```
<  POWER = [ival]: INTAKE P [ival] LAYER [ival]
    OUTLET P [ival] LAYER [ival]
    NAME [val]
>
```

**Explanation:**

INTAKE	M	Start of the section in which the intake-point is defined
P [ival]	M	Specification of a point-number defined under MESH – POINTS, at which the intake of water by the powerstation takes place, i.e. in which water leaves the model.
LAYER = [ival]	D	Layer-number of the intake- or outlet-point. Default = 0, which means that the intake/outlet is distributed over the total water column.
OUTLET	M	Start of the section in which the outlet-point is defined
P = [ival]	M	Specification of a point-number defined at which the outlet of water by the powerstation takes place, i.e. in which water re-enters the model.
NAME = [val]	O	Optional name for the powerstation.

## 2.7 GENERAL (optional)

General information about the model is given in this section, such as physical parameters and wind data related input. This section is optional.

### GENERAL

DIFFUSION

PHYSICALPARAMETERS

WIND

SPACE\_VAR\_WIND

KALMAN

CORIOLIS

SPACE\_DEP\_CD

SVWP\_LS\_MASK

METEO\_DATA

TIDAL\_FORCES

### 2.7.1 DIFFUSION (optional)

In this subsection the diffusion coefficient DIFCO (in  $m^2 s^{-1}$ ) can be given. Diffusion coefficients are defined in water level points. The format for the diffusion coefficient is according to the description of data fields (par. 2.1.2).

In GLOBAL a uniform value or special varying values for the diffusion coefficients DIFCO are given for the whole grid (see par. 2.1.2.1).

In LOCAL these diffusion values can be locally overwritten with values specified in boxes (see par. 2.1.2.2).

#### DIFFUSION

GLOBAL

LOCAL

#### 2.7.1.1 GLOBAL (mandatory)

##### GLOBAL

LAYOUT = [*ival*]

| CONST\_VALUES = [*val*]

<

| VARIABLE\_VALUES = <[*val*]>

#### **Explanation:**

CONST\_VALUES = [*val*]

D

See paragraph 2.1.2.1. ( $m^2 s^{-1}$ )



VARIABLE_VALUES = < [val] >	O	Default = 10.0 See paragraph 2.1.2.1. ( $m^2s^{-1}$ )
LAYOUT = [ival]	D	See paragraph 2.1.2.1. Default = 1

### 2.7.1.2 LOCAL (optional)

See paragraph 2.1.2.2 for this subsection.

## 2.7.2 PHYSICAL PARAMETERS (optional)

The physical parameters gravity, water density, air density and dynamic viscosity of water can be defined in this subsection.

### PHYSICALPARAMETERS

GRAVITY = [val]  
WATDENSITY = [val]  
AIRDENSITY = [val]  
DYNVISCOSITY = [val]

### Explanation:

GRAVITY=[val]	D	Gravity ( $ms^{-2}$ ) Default = 9.813
WATDENSITY=[val]	D	Water density ( $kgm^{-3}$ ) Default = 1023.0
AIRDENSITY=[val]	D	Air density ( $kgm^{-3}$ ) Default = 1.205
DYNVISCOSITY=[val]	D	Dynamic viscosity of water ( $kgm^{-1}s^{-1}$ ) Default = 0.001

### 2.7.3 WIND (optional)

In this section the effect of uniform (constant in space) wind can be taken into account.

### WIND

WSPEED = [val]  
WANGLE = [val]  
WCONVERSIONFACTOR = [val]  
WUNIT = [text]  
| CONST\_CD : WSTRESSCOEFFICIENT = [val]  
<  
| VARIABLE\_CD : CDA [val]      CDB [val]      WIND\_CDA [val]      WIND\_CDB = [val]  
<

```

| CHARNOCK : BETA [val]      HEIGHT [val]
| SERIES [text]
| FRAME [val1][val2][val3]
| VALUES = < [val1][val2]>                                     (i.c. series='regular')
<
| <TIME_AND_VALUES = [tval][val1][val2]                         (i.c. series='irregular')>

```

### Explanation:

WSPEED=[val]	D	Global wind speed in a dimension specified by WUNIT. Default = 0.0
WANGLE=[val]	D	Global wind direction, in degrees from 0 to 360. Wind direction is measured clockwise from north, where (wind coming from) north equals to 0°, (wind coming from) east equals 90° and so on. Default = 0

Note: Remark the difference in specifying the angles for wind direction (WANGLE) and the model (ANGLEGRID, see section 2.6.1.1). The first must be given in degrees from the North where the wind is coming from, while the model angle is measured from the positive Y-direction to the North, both clockwise.

WCONVERSIONFACTOR = [val]	D	Wind conversion factor, converts the dimension of the wind speed specified by WUNIT to $ms^{-1}$ . Thus if wind speed is given in knots, then WCONVERSIONFACTOR must be set to 0.5144. Default = 1.0
WUNIT = [text]	O	Name of wind speed unit to display. The maximum length of text is 4 characters.
CONST_CD	D	CONST_Cd is a flag-keyword. If this keyword is specified, a wind speed-independent $C_d$ -coefficient, defined with the keyword. WSTRESSCOEFFICIENT will be used in the computation of the force due to wind.
WSTRESSCOEFFICIENT = [val]	D	Coefficient used in the computation of the force due to wind. Should be specified together with the keyword CONST_Cd. Default = 0.0026

- VARIABLE\_CD ○ VARIABLE\_Cd is a flag-keyword. If this keyword is specified, a wind speed-dependent  $C_d$ -coefficient, defined with the keywords: CdA, CdB, WIND\_CdA and WIND\_CdB will be used in the computation of the force due to wind.
- CDA = [val], CDB = [val] ○ Two coefficients used in the computation of the force due to wind. Should be specified together with the keyword VARIABLE\_Cd.
- WIND\_CDA=[val], WIND\_CDB=[val] ○ Two wind speed-values used to calculate the  $C_d$ -coefficient. Should be specified together with the keyword VARIABLE\_Cd.

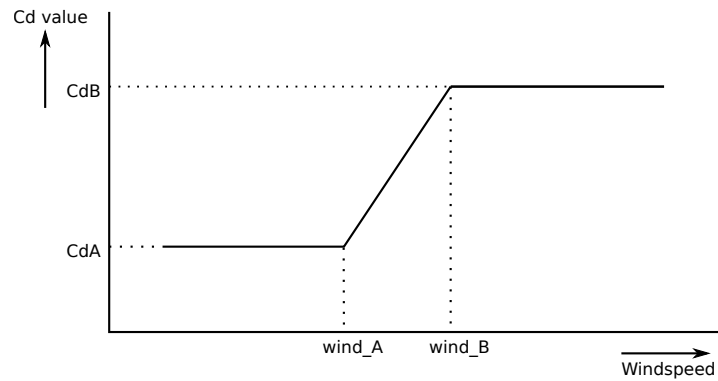

Figure 2.1: Cd coefficient related to wind speed

Note: For the computation of the Cd-coefficient that depends piecewise linearly on wind speed, we need both lower and upper bounds of the coefficients and speeds. The following rules are applied when calculating the wind drag coefficient:

if wind speed  $\leq$  WIND\_CdA:  $C_d = C_{dA}$

if wind speed  $<$  WIND\_CdB:  $C_d = C_{dB}$

For the wind speed-values between WIND\_CdA and WIND\_CdB the Cd-coefficient is obtained by means of linear interpolation between CdA and CdB, refer to Fig. 2.1 .

- CHARNOCK ○ CHARNOCK is a flag keyword. If this keyword is specified, a wind drag coefficient  $C_d$  depending on wind speed in an implicit manner based on the Charnock drag formulation will be used in the computation of the force due to wind.
- BETA = [val] D The dimensionless Charnock coefficient.  
Default = 0.032

`HEIGHT = [val]`    D         The height (m) above the free surface where the wind speed has been measured.  
Default = 10.0

Note: Based on the mixing length theory, the velocity of the wind in the turbulent layer above the free surface follows a logarithmic velocity profile in which the friction velocity  $u_*$  and the roughness height  $z_0$  have to be determined. Charnock (1955) proposed the following relation for the roughness height:  $z_0 = \beta u_*^2 / g$  with  $\beta$  the dimensionless Charnock coefficient and  $g$  the gravity acceleration.

`SERIES = [text]`    O         SERIES can have two possible values: 'regular' or 'irregular'. When SERIES = 'regular' keywords FRAME and VALUES are expected. When SERIES = 'irregular' keyword TIME\_AND\_WIND\_VALUES is expected.

`FRAME = [val1] [val2] [val3]`    O         *[val1]* is the first time for which wind speed and angle are given. *[val2]* is the time interval at which wind speed and angle are given. *[val3]* is the last time at which wind speed and angle are given. (All these times are given in minutes)

`VALUES = < ([val1] [val2]) >`    O         The values for wind speed (*=[val1]*) (dimension: See WUNIT) and angle (*=[val2]*) (dimension: See WANGLE) are given for the times as defined at the keyword frame.

`TIME_AND_WINDVALUES = [tval][val1][val2]`    O         In this case it is possible to give wind speed and angle at non-equidistant times.

## 2.7.4 SPACE\_VAR\_WIND (optional)

In this section the effect of spatially varying wind and pressure (SVWP) can be taken into account. This option should not be used together with the option WIND, used to specify uniform wind.

The spatially varying wind can either be expressed as wind speeds or as wind stresses. When expressed as stresses, the wind drag coefficient has already been taken into account in the input and thus does not need to be specified here. The wind conversion factor still depends on the dimension of the wind speeds used to compute the stresses.

### SPACE\_VAR\_WIND

`WCONVERSIONFACTOR [val]`

`WUNIT [text]`

| `CONST_CD : WSTRESSCOEFFICIENT [val]`

<

| `VARIABLE_CD : CDA = [val]          CDB = [val]`

```

                                WIND_CDA = [val]      WIND_CDB = [val]
<
| CHARNOCK : BETA = [val]      HEIGHT = [val]
<
| STRESS
| SDS_SVWP = [text]
| EXP_SVWP = [text]
| CORRECT_BOUND
| SKIP_PART
| LSMASK : LANDFRACTION = [val]

```

**Explanation:**

<u>WCONVERSIONFACTOR</u> = [val]	D	Wind conversion factor, converts the dimension of the wind speed specified by <u>WUNIT</u> to $ms^{-1}$ . Thus if wind speed is given in knots, then <u>WCONVERSIONFACTOR</u> must be set to 0.5144. Default = 1.0
<u>WUNIT</u> = [text]	O	Name of wind speed unit to display.
<u>CONST_CD</u>	D	<u>CONST_Cd</u> is a flag-keyword. If this keyword is specified, a wind speed-independent $C_d$ -coefficient, defined with the keyword <u>WSTRESSCOEFFICIENT</u> will be used in the computation of the force due to wind.
<u>WSTRESSCOEFFICIENT</u> = [val]	D	Coefficient used in the computation of the force due to wind. Should be specified together with the keyword <u>CONST_Cd</u> . Default = 0.0026
<u>VARIABLE_CD</u>	O	<u>VARIABLE_Cd</u> is a flag-keyword. If this keyword is specified, the wind speed-dependent $C_d$ -coefficient, defined with the keywords: <u>CdA</u> , <u>CdB</u> , <u>WIND_CdA</u> and <u>WIND_CdB</u> will be used in the computation of the force due to wind.
<u>CDA</u> = [val], <u>CDB</u> = [val]	O	Two coefficients used in the computation of the force due to wind. Should be specified together with the keyword <u>VARIABLE_Cd</u> .
<u>WIND_CDA</u> = [val], <u>WIND_CDB</u> = [val]	O	Two wind speed-values used to calculate the $C_d$ -coefficient. Should be specified together with the keyword <u>VARIABLE_Cd</u> . The following rules are applied when calculating the $C_d$ -coefficient: if wind speed $\leq$ <u>WIND_CdA</u> : $C_d = C_{dA}$ if wind speed $>$ <u>WIND_CdB</u> : $C_d = C_{dB}$

For the wind speed-values between WIND\_CdA and WIND\_CdB the Cd-coefficient is obtained by means of linear interpolation between CdA and CdB, refer to Fig. 2.1.

- |              |   |  |
|--------------|---|--|
| CHARNOCK     | O | CHARNOCK is a flag keyword. If this keyword is specified, a wind drag coefficient $C_d$ depending on wind speed in an implicit manner based on the Charnock drag formulation will be used in the computation of the force due to wind. |
| BETA=[val]   | D | The dimensionless Charnock coefficient.<br>Default = 0.032   |
| HEIGHT=[val] | D | The height (m) above the free surface where the wind speed has been measured.<br>Default = 10.0  |

Note: Based on the mixing length theory, the velocity of the wind in the turbulent layer above the free surface follows a logarithmic velocity profile in which the friction velocity  $u_*$  and the roughness height  $z_0$  have to be determined. Charnock (1955) proposed the following relation for the roughness height:  $z_0 = \beta u_*^2/g$  with  $\beta$  the dimensionless Charnock coefficient and  $g$  the gravity acceleration.

- |        |   |  |
|--------|---|--|
| STRESS | O | STRESS is a flag-keyword.<br>This keyword is not used! Whether the KNMI file contains wind stresses or wind speeds, is determined by reading the flag <i>istres</i> directly from the wind SDS-file. |
|--------|---|--|

Notes: - This keyword will be completely removed in the future!

- If the KNMI file contains wind stresses, CD-coefficients should not be specified. If, in such a case, CD-coefficients are still specified, their values will be ignored.

- |                 |   |   |
|-----------------|---|---|
| SDS_SVWP=[text] | M | Name of the SDS-file with the Space Varying Wind and Pressure data. The given file name can contain an explicit path name. The use of any indication of a parent directory ('..') is allowed. This file must be produced by the program WAQWND (conversion of the binary KNMI-wind files to the SIMONA format). |
|-----------------|---|---|

EXP_SVWP= <i>[text]</i>	O	Name of the experiment on the wind SDS-file, containing the Space Varying Wind and Pressure data to be used by the simulation program.
CORRECT_BOUND	D	If CORRECT_BOUND is specified in the input, the boundary conditions at water level points will be corrected for the local pressure. Default: No correction of boundary conditions is performed.
SKIP_PART	D	If SKIP_PART is specified in the input, the wind-SDS file will not be partitioned when using domain-decomposition or parallel computing. This saves time at the startup of the computation, but can increase the computation time in the time loop. Default: The wind-SDS file will be partitioned.
LSMASK	O	Use the land-sea mask from the windfile. This mask must exist on the windfile (only GRIB or NetCDF). If it does not exist, an error will occur. If it exists, then the mask is converted to a 0-1 grid (using LANDFRACTION as a boundary) and the same calculations are done as if you are using SVWP_LS_MASK.
LANDFRACTION= <i>[val]</i>	D	On the windfiles, the land-sea mask is given by fractions. In Waqua we use flags (0 or 1). This parameter determines if a fraction is converted to 0 (fraction on windfile < land-fraction) or to 1 (fraction on windfile $\geq$ land-fraction) Default = 0.50

- Notes:
- The Space Varying Wind and Pressure data will normally be given on the same type of grid as the grid used in WAQUA (i.e. either spherical or planar). However, a spherical wind grid is also allowed on a planar WAQUA-grid.
  - The SVWP-data are interpolated in space from the (rectangular) wind-grid to the WAQUA-grid using standard SIMONA interpolation tools. As the extrapolation of data is not supported by these tools, the WAQUA-grid should be covered completely by the wind-grid.
  - WAQUA performs time-interpolation of the SVWP-data. The general rules for interpolation of time-series apply also in this case.
  - If the SVWP data begin later than the simulation, the wind velocity/stress and atmospheric pressure will be interpolated between the initial condition (using zero wind velocity and pressure equal to the mean pressure) and the first instance for which data are found on the wind-file.

- If the SVWP data end earlier than the simulation, the wind stress and atmospheric pressure gradient will be kept constant using the last values read from the wind-file.
- If EXP\_SVWP is not specified, the first experiment on the specified SDS file will be taken.
- If LSMASK is specified, then the option SKIP\_PART should also be used. If it is not set by yourself then it will be activated automatically and a warning is given.

## 2.7.5 KALMAN (optional)

In this subsection the parameters for Kalman filtering can be given. Some general information can be found in *Kalman Filtering with WAQUA* (Kalman\_handleiding.pdf).

When using a Kalman filtering technique, the simulation input file for WAQUA/TRIWAQ must be extended with one main keyword:

```
KALMAN  
  | STEADY_STATE  
<  
  | RRSQRT  
<  
  | OPENDA
```

Either one of the subkeywords must be specified, and will be described in the next sections.

In addition, when using the boundary smoothing option (RRSQRT), WAQUA's input paragraph "sdsoutput" can be extended with sub-paragraph KALMAN\_HISTORIES. See section 3.1 in *Kalman Filtering with WAQUA* (Kalman\_handleiding.pdf).

### 2.7.5.1 STEADY\_STATE

This keyword specifies the use of a steady state Kalman filter in WAQUA/TRIWAQ (Chandrasekhar or RRSQRT type). In this block the sds filename is specified and the name of the experiment in which the Kalman filter gain was computed. When the gain was computed using the RRSQRT algorithm, the time at which the gain was computed must be specified as well.

```
STEADY_STATE  
  SDS_KALMAN  
  EXP_KALMAN  
  GAIN_TIME  
  FORECAST_START
```

#### Explanation:



SDS_KALMAN= <i>[text]</i>	M	The name of the sds file in which the Kalman filter gain is stored.
EXP_KALMAN= <i>[text]</i>	O	The name of the experiment in this SDS file.
GAIN_TIME= <i>[val]</i>	O	The time in minutes at which the gain was stored in the Waqua-with-RRSQRT Kalman experiment.
FORECAST_START= <i>[val]</i>	O	The time in minutes at which the forecast starts. Default: forecast starts at the end of observed data.

Notes: - If EXP\_KALMAN is not specified, the first experiment on the specified sds file will be taken.

### 2.7.5.2 RRSQRT

This keyword specifies the use of a RRSQRT Kalman filter in WAQUA/TRIWAQ. In this block the parameters are defined, the measurement data to assimilate is specified and the times are given at which a steady state gain must be computed.

#### RRSQRT

GENERAL  
WATERLEVEL\_STATIONS  
CURRENT\_STATIONS  
SALINITY\_STATIONS  
TRACKS  
WIND\_NOISE  
BOUNDARIES  
VISCOSITY\_NOISE  
COMPUTE\_STEADY\_STATE

#### **GENERAL (mandatory)**

General input for the RRSQRT filter algorithm is given in this subsection.

#### GENERAL

NMODE = *[ival]*  
CHAR\_DIST = *[val]* [kilometer, meter, rad, degree]  
FORGET\_PAST = *[val]*  
TIKAL *[val]*  
FORECAST\_START = *[val]*

#### **Explanation:**

NMODE= <i>[ival]</i>	M	Number of modes.
CHAR_DIST= <i>[val]</i>	D	Characteristic distance in fractions of grid points, used to compute the covariance matrices of the noise parameters (spatial dependency). The covariance of noise values at locations which are CHAR_DIST apart, is 1/e ( $\approx 0.37$ ) times as large as the noise variance. Unit: specified by the keywords KILOMETER, METER, RAD, DEGREE . When no unit is specified, the unit is one mesh size. Default = (length of the diagonal of the computational area) / 10.
FORGET_PAST= <i>[val]</i>	D	The forget factor. Not used in the current release. Default = 1
TIKAL= <i>[val]</i>	D	The time interval in minutes for recomputation of the second part of the Kalman matrix L. Default = dt (time step)
FORECAST_START= <i>[val]</i>	O	The time in minutes at which the forecast starts.

- Notes:
- The number of modes has great effect on the stability of the forecast and on the computation time. Too few modes may lead to instabilities, too many modes will result in very large computation times.
  - The characteristic distance is used in the computation of the covariance matrix for the wind noise and boundary parameters. In the current release, the characteristic distance for boundary parameters can only be specified in this section. Using spatial uncorrelated boundary parameters can be specified by setting this distance to 0.
  - When the boundary noise is smoothed, the time series of the adapted boundary values are saved in the SDS file and can be read by the procedure "getser.pl".

## WATERLEVEL\_STATIONS (optional)

In this subsection the waterlevel locations are given at which observed data is available that must be used to assimilate the outcome of WAQUA.

### WATERLEVEL\_STATIONS

```
| S : P [iseq] STANDARD_DEV =[val]
<
| S : STATION [text] STANDARD_DEV =[val]
```

**Explanation:**

$P=[iseq]$	X	Point sequence number as defined in mesh.
$STATION=[text]$	X	Station name as defined in mesh (points). Equivalence of station names is tested case-insensitive and ignoring spaces.
$STANDARD\_DEV=[val]$	D	Standard deviation in meters (m) of the errors in the observed data. Default = 0.05

**CURRENT\_STATIONS (optional)**

In this subsection the current locations are given at which observed data is available that must be used to assimilate the outcome of waqua.

CURRENT\_STATIONS

S : STATION *[text]* STANDARD\_DEV =*[val]*

**Explanation:**

$STATION=[text]$	X	Station name as defined in the observed data input file. Equivalence of station names is tested case-insensitive and ignoring spaces. Example: osm107. As currents consist of 2 components (u and v), the station name is translated to <name>-u and <name>-v in the lds.
$STANDARD\_DEV=[val]$	D	Standard deviation in meters (m) of the errors in the observed data. Default = 0.05

**SALINITY\_STATIONS (optional)**

In this subsection the locations are given at which observed salinities are available that must be used to assimilate the outcome of waqua.

SALINITY\_STATIONS

S : STATION *[text]* STANDARD\_DEV =*[val]*

**Explanation:**

STATION= <i>[text]</i>	X	Station name as defined in the observed data input file. Equivalence of station names is tested case-insensitive and ignoring spaces.
STANDARD_DEV= <i>[val]</i>	D	Standard deviation in kilogram per cubic meter ( $kg/m^3$ ) of the errors in the observed data. Default = 0.05

## TRACKS (currently not supported)

**Note:** tracks are currently not supported

In this subsection the “tracks” are given at which observed data is available that must be used to assimilate the outcome of waqua. The name “track” is originated from satellite data, but in fact different kinds of space-varying observed data can be specified here.

### TRACKS

```
| S : CURRENT [text] STANDARD_DEV =[val]
<
| S : WATERLEVEL [text] STANDARD_DEV =[val]
```

### Explanation:

CURRENT= <i>[text]</i>	X	Name of the data sample as defined in the observed data input file. Equivalence of names is tested case-insensitive and ignoring spaces. Example: HFRADAR.
WATERLEVEL= <i>[text]</i>	X	Name of the data sample as defined in the observed data input file. Equivalence of names is tested case-insensitive and ignoring spaces. Example: SATELLITE or POSEIDON.
STANDARD_DEV= <i>[val]</i>	D	Standard deviation in meters (m) of the errors in the observed data. Default = 0.05

## WIND\_NOISE (optional)

In this subsection the parameter points for wind noise are defined.

### WIND\_NOISE

#### STATISTICS

#### STRESS

```
STANDARD_DEV =[val]
```

CHAR\_TIME =  $[val]$   
CHAR\_HOR =  $[val]$  [kilometer, meter, rad, degree]

**GRID**

M\_INCREMENT =  $[ival]$   
N\_INCREMENT =  $[ival]$   
M\_START =  $[ival]$   
N\_START =  $[ival]$   
  
[kilometer, meter, rad, degree]  
NORTH\_INCREMENT =  $[val]$   
EAST\_INCREMENT =  $[val]$   
NORTH\_START =  $[val]$   
EAST\_START =  $[val]$

**Explanation:**

STRESS	D	Flag: when specified, the wind noise is added to the wind stress (input forcing), otherwise to the water velocities (output state). Default: noise on velocities.
STANDARD_DEV= $[val]$	D	Standard deviation of the errors in the wind stress respective in the effect of wind stress on the velocities. The unit in which this keyword is given is <ul style="list-style-type: none"> <li>- Pascal <math>[N/m^2]</math>, when the keyword stress is specified and standard_dev is at least 0.005 Pascal.</li> <li>- <math>[F/m^2]</math>, where F is the force necessary to accelerate one <math>m^3</math> of water by one <math>m/s^2</math>, when the keyword stress is specified and standard_dev is less than 0.005 <math>F/m^2</math>.</li> <li>- Meter per second <math>[m/s]</math>, when the keyword stress is not specified.</li> </ul> Default = 0.003 $[m/s$ or $F/m^2]$ .
CHAR_TIME= $[val]$	D	Characteristic time for the noise. The covariance of the noise at the same location, at times which differ the characteristic time, is $1/e$ ( $\approx 0.37$ ) times the variance of the noise. An alternative keyword is time_correlation: the ratio of the covariance of noise at times which differ one timestep, and the variance. TIME_CORRELATION and CHAR_TIME are related as

- TIME\_CORRELATION =  
exp(-TSTART/CHAR\_TIME)
- CHAR\_TIME =  
TSTART/log(TIME\_CORRELATION)

Default:

- TIME\_CORRELATION =0.9
- CHAR\_TIME = 9.5 TSTART

CHAR\_HOR=*[val]*

D

Characteristic distance in the wind stress. The covariance of noise values at locations which are CHAR\_HOR apart, is 1/e ( $\approx 0.37$ ) times as large as the noise variance.

Default = characteristic distance given in the general subsection.

Unit: indicated using the keyword KILOMETER, METER, DEGREE or RAD (Default unit: as specified in the general subsection).

An alternative keyword is CHAR\_PSI. Its meaning is identical.

M\_INCREMENT=*[ival]*, N\_INCREMENT=*[ival]*,  
M\_START=*[ival]*, N\_START=*[ival]*

O

Specification of the wind noise grid in (m,n) coordinates. The wind noise grid consists of the points

$(m,n)=(m\_start + k1*m\_increment, n\_start + k2*n\_increment)$ ,

where k1 and k2 are integers. All points which may possibly influence the waqua grid are included in the wind grid, even those with negative m or n coordinates or coordinates outside the WAQUA grid.

Defaults: m\_start=1, n\_start=1.

The wind noise grid must be specified in (m,n) coordinates or in physical coordinates, not both. In DDHOR-models, only physical coordinates are allowed.

NORTH\_INCREMENT=*[val]*,  
EAST\_INCREMENT=*[val]*, NORTH\_START=*[val]*,  
EAST\_START=*[val]*

O

Specification of the noise wind grid in physical coordinates. The wind noise grid consists of the points

$(x,y)=(east\_start + k1*east\_increment, north\_start + k2*north\_increment)$ ,

where k1 and k2 are integers. All points which may possibly influence the waqua grid are included in the wind grid, even those with negative m or n coordinates or coordinates outside the waqua grid.

Unit: specified by the keyword KILOMETER, METER, DEGREE or RAD.

The wind noise grid must be specified in (m,n) coordinates or in physical coordinates, not both. In DDHOR-models, only physical coordinates are allowed.

- Notes: - The wind “grid” is a regular grid which always overlaps the complete WAQUA grid. The reference point is part of the wind grid. Wind noise at WAQUA grid points is computed by linear interpolation of the noise at wind grid points.
- The standard deviation for windstress can be given in two different units:

- 1)  $\sigma_{stress}$   $[Nm^{-2}]$  (SI-unit for stress)
- 2)  $\sigma_{stress}/\rho_{water}$   $[Nm/kg]$

- An indication for the standard deviation can be computed as follows:

$$\begin{aligned} |\tau_{wind}| &= C_d \rho_a v^2 \\ &\approx (0.0028)(1.205 kgm^{-3})(5.5m/s)^2 \text{ (example)} \\ &= 0.102 Nm^{-2} \end{aligned}$$

This leads to a first order guess:

$$\sigma_{stress} = 2C_d \rho_a \bar{v} \sigma_{windspeed}$$

- When the wind noise is added to the water velocities instead of the wind stress, the standard deviation  $\sigma_{\Delta u}$  must be given. This is derived from the correction of velocities due to wind stress:

$$\delta u \approx \frac{\nu^2 \rho_a C_d \delta t}{\rho_w H} = \frac{\tau \delta t}{\rho_w H}$$

For 2D models, this leads to a standard deviation of approximate:

$$\sigma_{\Delta u} \approx \frac{\Delta t}{\rho_w H} \sigma_{\Delta \tau}$$

- For the comparison of experiments with the two different steady state filters,  $\sigma_{\Delta u}$  must be recomputed as follows:

$$\sigma_{new} \approx \frac{\sigma_{old} (1 - \alpha)}{\sqrt{1 - \alpha^2}}$$

with:

- $\sigma_{new}$  : the standard deviation for the wind using the RRSQRT type filter
- $\sigma_{old}$  : the standard deviation for the wind using the Chandrasekhar type filter
- $\alpha$  : the correlation in time

## VISCOSITY\_NOISE (optional)

In this subsection the parameter points for noise on vertical eddy viscosity are defined (only relevant in TRIWAQ).

VISCOSITY\_NOISE  
STATISTICS

STANDARD\_DEV = [val]  
CHAR\_TIME = [val]  
CHAR\_HOR = [val] [kilometer, meter, rad, degree]  
CHAR\_VERT = [val]

GRID

K\_INCREMENT = [ival]  
M\_INCREMENT = [ival]  
N\_INCREMENT = [ival]  
M\_START = [ival]  
N\_START = [ival]

[kilometer, meter, rad, degree]  
NORTH\_INCREMENT = [val]  
EAST\_INCREMENT = [val]  
NORTH\_START = [val]  
EAST\_START = [val]

**Explanation:**

<u>STANDARD_DEV</u> =[val]	D	Standard deviation of the errors in the vertical viscosity. Default = 0.003
<u>CHAR_TIME</u> =[val]	D	Characteristic time. Default = 9.5*tstart.
<u>CHAR_HOR</u> =[val]	D	Horizontal characteristic distance. Default = characteristic distance given in the general subsection.
<u>CHAR_VERT</u> =[val]	D	Vertical characteristic distance. Default = 0.5*kmax
<u>K_INCREMENT</u> =[ival]	M	Increment in waqua grid points in z-direction
<u>M_INCREMENT</u> =[ival], <u>N_INCREMENT</u> =[ival], <u>M_START</u> =[ival], <u>N_START</u> =[ival]	O	Specification of the viscosity noise grid.  Defaults: m_start=1, n_start=1.
<u>NORTH_INCREMENT</u> =[val], <u>EAST_INCREMENT</u> =[val], <u>NORTH_START</u> =[val], <u>EAST_START</u> =[val]	O	Specification of the viscosity noise grid.
		Unit: specified by the keyword KILOMETER, METER, DEGREE or RAD.

**BOUNDARIES (optional)**

Noise parameter points at open waterlevel boundaries are defined in this subsection.

BOUNDARIES

STATISTICS

STANDARD\_DEV = [val]



```

    SMOOTH =[val]
    WEIGHT_SMOOTH =[val]
    POINTS_INTPOL =[ival]
WATER_LEVELS
    STANDARD_DEV =[val]
VELOCITIES
    STANDARD_DEV =[val]
DISCHARGES
    STANDARD_DEV =[val]
RIEMAN_INVARIANTS
    STANDARD_DEV =[val]
LINE_SECTIONS
    <S :SECTION =[ival]1,[ival]2>

```

**Explanation:**

<u>STANDARD_DEV</u> = <i>[val]</i>	D	Global standard deviation of the errors in the boundary conditions: Default = 0.10 units: waterlevels: meters (m). velocities: meters per second (m/s) discharges: relative error (x 100)% Riemann invariants: relative error (x 100%) disch-ad: relative error (x 100%) qh-tables: meters of water level (m)
<u>CHAR_TIME</u> = <i>[val]</i>	D	Characteristic time. Default = 9.5*tstart
<u>SMOOTH</u> = <i>[val]</i>	D	The time period in minutes for smoothing the boundary noise. Default = 0.
<u>WEIGH_SMOOTH</u> = <i>[val]</i>	D	Relative weight of the variables used for smoothing the boundary noise. Every time step in the smoothing time period requires the storage of as many variables in the state vector as the boundary noise parameters. When these variables are scaled with the same weights as the boundary noise parameters themselves, they are over-represented when a large smoothing period is used. The keyword <b>weigh_smooth</b> can be used to obtain a more optimal scaling.

		Default: <b>weigh_smooth = smooth/tstep</b> ; smoothing variables have the same weight as boundary noise.
POINTS.INTPOL={ival}	D	The number of points to be used for in- terpolation. 2=linear interpolation (1 <sup>st</sup> de- gree), 4=3 <sup>rd</sup> degree interpolation, etc. (refer to paragraph 2.2 of <i>Kalman Filtering with</i> WAQUA (Kalman_handleiding.pdf).) Default = 2
SECTION={ival1},{ival2}	M	The starting and ending line section num- ber of which at the outer ends uncertain pa- rameters are defined. All points between the two parameters along the boundary line must concern open boundary points (no gaps allowed). Overlap is not allowed ei- ther. Boundary condition filter values are linear interpolated between the two parame- ter points.
WATER_LEVELS	O	keyword to indicate that the standard devi- ation in the error of water level and qh-table boundaries differs from the global standard deviation
VELOCITIES	O	keyword to indicate that the standard devi- ation in the error of velocity boundaries differs from the global standard deviation
DISCHARGES	O	keyword to indicate that the standard devi- ation in the error of discharge and disch-ad boundaries differs from the global standard deviation
RIEMANN_INVARIANTS	O	keyword to indicate that the standard devi- ation in the error of Riemann invariant bound- aries differs from the global standard devia- tion

Notes: - For the comparison of experiments with the two different steady state filters,  $\sigma_h$  must be recomputed as follows:

$$\sigma_{new} = \frac{\sigma_{old}}{\sqrt{1 - \alpha^2}}$$

with:

- $\sigma_{new}$  : the standard deviation for the boundary using the RRSQRT type filter
- $\sigma_{old}$  : the standard deviation for the boundary using the Chandrasekhar type filter
- $\alpha$  : the correlation in time

**COMPUTE\_STEADY\_STATE (optional)**

During the RRSQRT filter computations steady state gains can be computed at a given time interval.

COMPUTE\_STEADY\_STATETFKALMAN = [val]TIKALMAN = [val]TLKALMAN = [val]**Explanation:**

<u>TFKALMAN</u> = [val]	D	Time in minutes relative to tstart to start computation of a gain (Time First). Default = tstart
<u>TIKALMAN</u> = [val]	M	Time Interval in minutes to compute a gain. Default = dtmin
<u>TLKALMAN</u> = [val]	D	Time in minutes relative to tstart to end computation of a gain (Time Last). Default = tstop

**2.7.5.3 OPENDA**

This keyword specifies the use of a Kalman filter in WAQUA/TRIWAQ using OpenDA.

OPENDAGENERALWATERLEVEL\_STATIONSCURRENT\_STATIONSSALINITY\_STATIONSWIND\_NOISEBOUNDARIESVISCOSITY\_NOISE**GENERAL (mandatory)**

General input for the Kalman filtering using OpenDA is given in this subsection.

GENERALCHAR\_DIST = [val] [kilometer, meter, rad, degree]**Explanation:**

CHAR_DIST= <i>[val]</i>	D	Characteristic distance in fractions of grid points, used to compute the covariance matrices of the noise parameters (spatial dependency). The covariance of noise values at locations which are CHAR_DIST apart, is 1/e ( $\approx 0.37$ ) times as large as the noise variance. Unit: specified by the keywords KILOMETER, METER, RAD, DEGREE . When no unit is specified, the unit is one mesh size. Default = (length of the diagonal of the computational area) / 10.
-------------------------	---	--

Notes: - The characteristic distance is used in the computation of the covariance matrix for the wind noise and boundary parameters. In the current release, the characteristic distance for boundary parameters can only be specified in this section. Using spatial uncorrelated boundary parameters can be specified by setting this distance to 0.

### WATERLEVEL\_STATIONS (optional)

In this subsection the waterlevel locations are given at which observed data is available that must be used to assimilate the outcome of WAQUA.

#### WATERLEVEL\_STATIONS

```
| S : P [iseq] STANDARD_DEV =[val]
<
| S : STATION [text] STANDARD_DEV =[val]
```

#### Explanation:

P= <i>[iseq]</i>	X	Point sequence number as defined in mesh.
STATION= <i>[text]</i>	X	Station name as defined in mesh (points). Equivalence of station names is tested case-insensitive and ignoring spaces.
STANDARD_DEV= <i>[val]</i>	D	Standard deviation in meters (m) of the errors in the observed data. Default = 0.05

### CURRENT\_STATIONS (optional)

In this subsection the current locations are given at which observed data is available that must be used to assimilate the outcome of waqua.

CURRENT\_STATIONS

S : STATION [*text*] STANDARD\_DEV = [*val*]

**Explanation:**

<u>STATION</u> =[ <i>text</i> ]	X	Station name as defined in the observed data input file. Equivalence of station names is tested case-insensitive and ignoring spaces. Example: osm107. As currents consist of 2 components (u and v), the station name is translated to <name>-u and <name>-v in the lds.
<u>STANDARD_DEV</u> =[ <i>val</i> ]	D	Standard deviation in meters (m) of the errors in the observed data. Default = 0.05

**SALINITY\_STATIONS (optional)**

In this subsection the locations are given at which observed salinities are available that must be used to assimilate the outcome of waqua.

SALINITY\_STATIONS

S : STATION [*text*] STANDARD\_DEV = [*val*]

**Explanation:**

<u>STATION</u> =[ <i>text</i> ]	X	Station name as defined in the observed data input file. Equivalence of station names is tested case-insensitive and ignoring spaces.
<u>STANDARD_DEV</u> =[ <i>val</i> ]	D	Standard deviation in kilogram per cubic meter ( $kg/m^3$ ) of the errors in the observed data. Default = 0.05

**WIND\_NOISE (optional)**

In this subsection the parameter points for wind noise are defined.

WIND\_NOISESTATISTICSSTRESS

STANDARD\_DEV = [*val*]

CHAR\_TIME = [*val*]

CHAR\_HOR = [*val*] [kilometer, meter, rad, degree]

GRID

M\_INCREMENT = [ival]

N\_INCREMENT = [ival]

M\_START = [ival]

N\_START = [ival]

[kilometer, meter, rad, degree]

NORTH\_INCREMENT = [val]

EAST\_INCREMENT = [val]

NORTH\_START = [val]

EAST\_START = [val]

**Explanation:**

STRESS

D Flag: when specified, the wind noise is added to the wind stress (input forcing), otherwise to the water velocities (output state). Default: noise on velocities.

STANDARD\_DEV=[val]

D Standard deviation of the errors in the wind stress respective in the effect of wind stress on the velocities.

The unit in which this keyword is given is

- Pascal [ $N/m^2$ ], when the keyword stress is specified and standard\_dev is at least 0.005 Pascal.
- [ $F/m^2$ ], where F is the force necessary to accelerate one  $m^3$  of water by one  $m/s^2$ , when the keyword stress is specified and standard\_dev is less than 0.005  $F/m^2$ .
- Meter per second [ $m/s$ ], when the keyword stress is not specified.

Default = 0.003 [ $m/s$  or  $F/m^2$ ].

CHAR\_TIME=[val]

D Characteristic time for the noise. The covariance of the noise at the same location, at times which differ the characteristic time, is  $1/e$  ( $\approx 0.37$ ) times the variance of the noise. An alternative keyword is time\_correlation: the ratio of the covariance of noise at times which differ one timestep, and the variance. TIME\_CORRELATION and CHAR\_TIME are related as

- TIME\_CORRELATION =  
exp(-TSTART/CHAR\_TIME)
  - CHAR\_TIME =  
TSTART/log(TIME\_CORRELATION)
- Default:
- TIME\_CORRELATION =0.9
  - CHAR\_TIME = 9.5 TSTART
- CHAR\_HOR=*[val]*      D      Characteristic distance in the wind stress. The covariance of noise values at locations which are CHAR\_HOR apart, is 1/e ( $\approx 0.37$ ) times as large as the noise variance. Default = characteristic distance given in the general subsection. Unit: indicated using the keyword KILOMETER, METER, DEGREE or RAD (Default unit: as specified in the general subsection). An alternative keyword is CHAR\_PSI. Its meaning is identical.
- M\_INCREMENT=*[ival]*, N\_INCREMENT=*[ival]*,  
M\_START=*[ival]*, N\_START=*[ival]*      O      Specification of the wind noise grid in (m,n) coordinates. The wind noise grid consists of the points  
(m,n)=(m\_start + k1\*m\_increment, n\_start + k2\*n\_increment),  
where k1 and k2 are integers. All points which may possibly influence the waqua grid are included in the wind grid, even those with negative m or n coordinates or coordinates outside the WAQUA grid. Defaults: m\_start=1, n\_start=1. The wind noise grid must be specified in (m,n) coordinates or in physical coordinates, not both. In DDHOR-models, only physical coordinates are allowed.
- NORTH\_INCREMENT=*[val]*,  
EAST\_INCREMENT=*[val]*, NORTH\_START=*[val]*,  
EAST\_START=*[val]*      O      Specification of the noise wind grid in physical coordinates. The wind noise grid consists of the points  
(x,y)=(east\_start + k1\*east\_increment, north\_start + k2\*north\_increment),  
where k1 and k2 are integers. All points which may possibly influence the waqua grid are included in the wind grid, even those with negative m or n coordinates or coordinates outside the waqua grid. Unit: specified by the keyword KILOMETER, METER, DEGREE or RAD.

The wind noise grid must be specified in (m,n) coordinates or in physical coordinates, not both. In DDHOR-models, only physical coordinates are allowed.

- Notes: - The wind “grid” is a regular grid which always overlaps the complete WAQUA grid. The reference point is part of the wind grid. Wind noise at WAQUA grid points is computed by linear interpolation of the noise at wind grid points.
- The standard deviation for windstress can be given in two different units:

- 1)  $\sigma_{stress}$   $[Nm^{-2}]$  (SI-unit for stress)
- 2)  $\sigma_{stress}/\rho_{water}$   $[Nm/kg]$

- An indication for the standard deviation can be computed as follows:

$$|\tau_{wind}| = C_d \rho_a v^2$$

$$\approx (0.0028)(1.205 kg m^{-3})(5.5 m/s)^2 \text{ (example)}$$

$$= 0.102 Nm^{-2}$$

This leads to a first order guess:

$$\sigma_{stress} = 2C_d \rho_a \bar{v} \sigma_{windspeed}$$

- When the wind noise is added to the water velocities instead of the wind stress, the standard deviation  $\sigma_{\Delta u}$  must be given. This is derived from the correction of velocities due to wind stress:

$$\delta u \approx \frac{\nu^2 \rho_a C_d \delta t}{\rho_w H} = \frac{\tau \delta t}{\rho_w H}$$

For 2D models, this leads to a standard deviation of approximate:

$$\sigma_{\Delta u} \approx \frac{\Delta t}{\rho_w H} \sigma_{\Delta \tau}$$

- For the comparison of experiments with the two different steady state filters,  $\sigma_{\Delta u}$  must be recomputed as follows:

$$\sigma_{new} \approx \frac{\sigma_{old} (1 - \alpha)}{\sqrt{1 - \alpha^2}}$$

with:

- $\sigma_{new}$  : the standard deviation for the wind using the RRSQRT type filter
- $\sigma_{old}$  : the standard deviation for the wind using the Chandrasekhar type filter
- $\alpha$  : the correlation in time

## VISCOSITY\_NOISE (optional)

In this subsection the parameter points for noise on vertical eddy viscosity are defined (only relevant in TRIWAQ).

VISCOSITY\_NOISE  
STATISTICS



STANDARD\_DEV = [val]  
CHAR\_TIME = [val]  
CHAR\_HOR = [val] [kilometer, meter, rad, degree]  
CHAR\_VERT = [val]

**GRID**

K\_INCREMENT = [ival]  
M\_INCREMENT = [ival]  
N\_INCREMENT = [ival]  
M\_START = [ival]  
N\_START = [ival]

[kilometer, meter, rad, degree]

NORTH\_INCREMENT = [val]  
EAST\_INCREMENT = [val]  
NORTH\_START = [val]  
EAST\_START = [val]

**Explanation:**

<u>STANDARD_DEV</u> =[val]	D	Standard deviation of the errors in the vertical viscosity. Default = 0.003
<u>CHAR_TIME</u> =[val]	D	Characteristic time. Default = 9.5*tstart.
<u>CHAR_HOR</u> =[val]	D	Horizontal characteristic distance. Default = characteristic distance given in the general subsection.
<u>CHAR_VERT</u> =[val]	D	Vertical characteristic distance. Default = 0.5*kmax
<u>K_INCREMENT</u> =[ival]	M	Increment in waqua grid points in z-direction
<u>M_INCREMENT</u> =[ival], <u>N_INCREMENT</u> =[ival], <u>M_START</u> =[ival], <u>N_START</u> =[ival]	O	Specification of the viscosity noise grid.  Defaults: m_start=1, n_start=1.
<u>NORTH_INCREMENT</u> =[val], <u>EAST_INCREMENT</u> =[val], <u>NORTH_START</u> =[val], <u>EAST_START</u> =[val]	O	Specification of the viscosity noise grid.  Unit: specified by the keyword KILOMETER, METER, DEGREE or RAD.

**BOUNDARIES (optional)**

Noise parameter points at open waterlevel boundaries are defined in this subsection.

**BOUNDARIES****STATISTICS**

STANDARD\_DEV = [val]

```

    SMOOTH = [val]
    WEIGHT_SMOOTH = [val]
    POINTS_INTPOL = [ival]
WATER_LEVELS
    STANDARD_DEV = [val]
VELOCITIES
    STANDARD_DEV = [val]
DISCHARGES
    STANDARD_DEV = [val]
RIEMAN_INVARIANTS
    STANDARD_DEV = [val]
LINE_SECTIONS
    <S :SECTION = [ival]1, [ival]2>

```

**Explanation:**

- |                                    |          |   |
|------------------------------------|----------|---|
| <p><u>STANDARD_DEV</u> = [val]</p> | <p>D</p> | <p>Global standard deviation of the errors in the boundary conditions:<br/>         Default = 0.10<br/>         units:<br/>             waterlevels: meters (m).<br/>             velocities: meters per second (m/s)<br/>             discharges: relative error (x 100)%<br/>             Riemann invariants: relative error (x 100%)<br/>             disch-ad: relative error (x 100%)<br/>             qh-tables: meters of water level (m)</p>                          |
| <p><u>CHAR_TIME</u> = [val]</p>    | <p>D</p> | <p>Characteristic time.<br/>         Default = 9.5*tstart</p>   |
| <p><u>SMOOTH</u> = [val]</p>       | <p>D</p> | <p>The time period in minutes for smoothing the boundary noise.<br/>         Default = 0.</p>   |
| <p><u>WEIGH_SMOOTH</u> = [val]</p> | <p>D</p> | <p>Relative weight of the variables used for smoothing the boundary noise. Every time step in the smoothing time period requires the storage of as many variables in the state vector as the boundary noise parameters. When these variables are scaled with the same weights as the boundary noise parameters themselves, they are over-represented when a large smoothing period is used. The keyword <b>weigh_smooth</b> can be used to obtain a more optimal scaling.</p> |

		Default: <b>weigh_smooth = smooth/tstep</b> ; smoothing variables have the same weight as boundary noise.
POINTS_INTPOL=[ival]	D	The number of points to be used for in- terpolation. 2=linear interpolation (1 <sup>st</sup> de- gree), 4=3 <sup>rd</sup> degree interpolation, etc. (refer to paragraph 2.2 of <i>Kalman Filtering with</i> WAQUA (Kalman_handleiding.pdf).) Default = 2
SECTION=[ival1],[ival2]	M	The starting and ending line section num- ber of which at the outer ends uncertain pa- rameters are defined. All points between the two parameters along the boundary line must concern open boundary points (no gaps allowed). Overlap is not allowed ei- ther. Boundary condition filter values are linear interpolated between the two parame- ter points.
WATER_LEVELS	O	keyword to indicate that the standard devi- ation in the error of water level and qh-table boundaries differs from the global standard deviation
VELOCITIES	O	keyword to indicate that the standard devi- ation in the error of velocity boundaries differs from the global standard deviation
DISCHARGES	O	keyword to indicate that the standard devi- ation in the error of discharge and disch-ad boundaries differs from the global standard deviation
RIEMANN_INVARIANTS	O	keyword to indicate that the standard devi- ation in the error of Riemann invariant bound- aries differs from the global standard devia- tion

Notes: - For the comparison of experiments with the two different steady state filters,  $\sigma_h$  must be recomputed as follows:

$$\sigma_{new} = \frac{\sigma_{old}}{\sqrt{1 - \alpha^2}}$$

with:

- $\sigma_{new}$  : the standard deviation for the boundary using the RRSQRT type filter
- $\sigma_{old}$  : the standard deviation for the boundary using the Chandrasekhar type filter
- $\alpha$  : the correlation in time

## 2.7.6 CORIOLIS (optional)

In this subsection the Coriolis coefficient FFZETA (in radians  $s^{-1}$ ) at water level points can be given. This will normally only apply in case of a curvilinear (or spherical coordinates) grid. The format for the Coriolis coefficient is according to the description of data fields (par. 2.1.2).

If the optional CORIOLIS-input is absent and we are dealing with a rectilinear or curvilinear grid, a global Coriolis coefficient will be used for the entire grid based upon the 'latitude'-value specified for the grid (refer to MESH-GRID-AREA section in this manual). If the optional CORIOLIS-input is absent and we are dealing with a spherical coordinates grid, a complete field of Coriolis coefficients will be derived from the local latitude of each water level point.

In GLOBAL a uniform value or special varying values for the Coriolis coefficients FFZETA are given for the whole grid (see par. 2.1.2.1).

In LOCAL these Coriolis coefficients can be locally overwritten with values specified in boxes (see par. 2.1.2.1).

### CORIOLIS

#### GLOBAL

#### LOCAL

### 2.7.6.1 GLOBAL (mandatory)

#### GLOBAL

```
LAYOUT = [ival]
| CONST_VALUES = [val]
<
| VARIABLE_VALUES = <[val]>
```

#### **Explanation:**

<u>CONST_VALUES</u> = <i>[val]</i>	O	See paragraph 2.1.2.1 (radians $s^{-1}$ )
<u>VARIABLE_VALUES</u> =< <i>[val]</i> >	O	See paragraph 2.1.2.1 (radians $s^{-1}$ )
<u>LAYOUT</u> = <i>[ival]</i>	D	See paragraph 2.1.2.1 Default = 1

### 2.7.6.2 LOCAL (optional)

See paragraph 2.1.2.2 for this subsection.

### 2.7.7 SPACE\_DEP\_CD (optional)

In this section space-dependent wind drag coefficient ( $C_d$ ) can be given. Both global and local spatial values for wind speed-independent and wind speed-dependent (in piecewise linear manner) wind drag coefficients can be taken into account.

This option should not be used when the keyword CONST\_Cd or VARIABLE\_Cd in sections WIND and SPACE\_VAR\_WIND are determined. In such situations, the values for CONST\_Cd or VARIABLE\_Cd will be ignored.

This section consists of two subsections:

```
SPACE_DEP_CD
  | WSPEED_INDEPENDENT
  <
  | WSPEED_PIECE_LINEAR
```

#### WSPEED\_INDEPENDENT (optional)

Wind speed-independent wind drag coefficient  $C_d$  to be used in the computation of the force due to wind can be defined here.

```
WSPEED_INDEPENDENT
  | GLOBAL      (see paragraph 2.1.2.1)
  <
  | LOCAL      (see paragraph 2.1.2.2)
```

#### WSPEED\_PIECE\_LINEAR (optional)

Wind drag coefficient  $C_d$  depending on wind speed in a piecewise continuous linear manner to be used in the computation of the force due to wind can be defined here. This keyword should be followed by the subkeywords Cd\_LOW and Cd\_HIGH, which are the lower and upper bounds of  $C_d$ , respectively.

```
WSPEED_PIECE_LINEAR
  CD_LOW
  CD_HIGH
```

#### Explanation:

CD\_LOW

- The lower bound used to calculate the wind drag coefficient.

CD\_LOW

GLOBAL

LOCAL

**GLOBAL (mandatory)**

GLOBAL

LAYOUT = [ival]      WSPEED\_LOW = [val]  
| CONST\_VALUES = [val]  
<  
| VARIABLE\_VALUES = <[val]>

**Explanation:**

- |  |   |   |
|--|---|---|
| <u>CONST_VALUES</u> = <i>[val]</i>       | O | See paragraph 2.1.2.1<br>Default = 0.0                                  |
| <u>VARIABLE_VALUES</u> =< <i>[val]</i> > | O | See paragraph 2.1.2.1   |
| <u>LAYOUT</u> = <i>[ival]</i>            | D | See paragraph 2.1.2.1<br>Default = 1                                    |
| <u>WSPEED_LOW</u> = <i>[val]</i>         | M | The lower bound of wind speed used to calculate the $C_d$ -coefficient. |

**LOCAL (mandatory)**

See paragraph 2.1.2.2 for this subsection.

**Explanation:**

- |                |   |  |
|----------------|---|--|
| <u>CD_HIGH</u> | O | The upper bound used to calculate the wind drag coefficient. |
|----------------|---|--|

CD\_HIGH

GLOBAL

LOCAL

**GLOBAL (mandatory)**

GLOBAL

LAYOUT = [ival]      WSPEED\_HIGH = [val]  
| CONST\_VALUES = [val]  
<  
| VARIABLE\_VALUES = <[val]>

**Explanation:**

CONST_VALUES= <i>[val]</i>	O	See paragraph 2.1.2.1 Default = 0.0
VARIABLE_VALUES=< <i>[val]</i> >	O	See paragraph 2.1.2.1
LAYOUT= <i>[val]</i>	D	See paragraph 2.1.2.1 Default = 1
WSPEED_HIGH= <i>[val]</i>	M	The upper bound of wind speed used to calculate the $C_d$ -coefficient.

**LOCAL (mandatory)**

See paragraph 2.1.2.2 for this subsection.

Note: For the computation of the  $C_d$ -coefficient that depends piecewise linearly on wind speed, we need both lower and upper bounds of the coefficients and speeds. The following rules are applied when calculating the wind drag coefficient

if wind speed  $\leq$  WSPEED\_LOW:  $C_d = C_{d\_LOW}$   
 if wind speed  $>$  WSPEED\_HIGH:  $C_d = C_{d\_HIGH}$

For the wind speed-values between WSPEED\_LOW and WSPEED\_HIGH the  $C_d$ -coefficient is obtained by means of linear interpolation between  $C_{d\_LOW}$  and  $C_{d\_HIGH}$ , refer to Fig. 2.1

**2.7.8 SVWP\_LS\_MASK(optional)**

In this section a land-sea mask can be specified for spatially varying wind and pressure. The mask specifies for every grid cell of the wind mesh whether it corresponds to a land point (1) or not (0). The land points are left out if the wind mesh is interpolated to the waqua mesh. There is one exception: in case all surrounding wind points for a point in the WAQUA mesh are masked out, the mask is ignored for that point. The specified size of the mask must correspond to the size of the wind mesh.

SVWP\_LS\_MASK

<u>GLOBAL</u>	(see paragraph 2.1.2.1)
<	
<u>LOCAL</u>	(see paragraph 2.1.2.2)

Notes: - If this section is specified, then the option SKIP\_PART in Section SPACE\_VAR\_WIND should also be used. If it is not set by yourself then it will be activated automatically and a warning is given.

- If the land-sea mask is available on the windfile, then it is also possible to use that mask. Instead of this section, you should use GENERAL-SPACE-VAR-WIND-LSMASK.

## GLOBAL (mandatory)

### GLOBAL

```

LAYOUT = [ival]      MMAX_WND = [val]      NMAX_WND = [val]
| CONST_VALUES = [val]
<
| VARIABLE_VALUES = <[val]>

```

### Explanation:

CONST_VALUES=[val]	O	See paragraph 2.1.2.1 Default = 0.0
VARIABLE_VALUES=<[val]>	O	See paragraph 2.1.2.1
LAYOUT=[ival]	D	See paragraph 2.1.2.1 Default = 1
MMAX_WND=[val]	M	Size of wind mesh in m-direction
NMAX_WND=[val]	M	Size of wind mesh in n-direction

## LOCAL (mandatory)

See paragraph 2.1.2.2 for this subsection.

## 2.7.9 METEO\_DATA (optional)

In this section meteo data can be specified for air temperature, humidity, cloud covering and solar irradiation.

### METEO\_DATA

```

SDS_METEO = [text]
EXP_METEO = [text]
AIR_TEMP
  TUNIT = [text]
  | T_AIR [val]
<
  | SERIES = [text]
  |   | FRAME = [val1][val2][val3]
  |   | VALUES = <[val]> (i.c. series='regular')
  |   <
  |   | <TIME_AND_VALUES = [tval][val]>

```



```

|     |
<
| USE_METEO_SDS
<
| SDS_AIR_TEMP = [text]
| EXP_AIR_TEMP = [text]
HUMIDITY
  HUNIT = [text]
  | R_HUMUDITY [val]
<
  | SERIES = [text]
  |     | FRAME = [val1][val2][val3]
  |     | VALUES = <[val]>
  |
  |     <
  |     | <TIME_AND_VALUES = [tval] [val]>
  |     |
  |
  |
  <
  | USE_METEO_SDS
  <
  | SDS_HUMIDITY = [text]
  | EXP_HUMIDITY = [text]
CLOUD_COVER
  CUNIT = [text]
  | T_CLOUD_COVER [val]
<
  | SERIES = [text]
  |     | FRAME = [val1][val2][val3]
  |     | VALUES = <[val]>
  |
  |     <
  |     | <TIME_AND_VALUES = [tval] [val]>
  |     |
  |
  |
  |
  <
  | USE_METEO_SDS
  <
  | SDS_CLOUDCOV = [text]
  | EXP_CLOUDCOV = [text]
SOLAR_RADIATION
  SUNIT = [text]
  | S_SOLAR [val]
<
  | SERIES = [text]
  |     | FRAME = [val1][val2][val3]
  |     | VALUES = <[val]>
  |
  |     <
  |     | <TIME_AND_VALUES = [tval] [val]>
  |     |
  |
  |
  |
  <
  | USE_METEO_SDS
  <
  | SDS_SOLAR = [text]
  | EXP_SOLAR = [text]

```

(i.c. series='regular')

(i.c. series='regular')

(i.c. series='regular')

(i.c. series='regular')

(i.c. series='regular')

(i.c. series='regular')

```

|   |
<
| USE_METEO_SDS
<
| SDS_SOLAR_IRRAD = [text]
| EXP_SOLAR_IRRAD = [text]

```

(i.c. series='regular')

**Explanation:**

- SDS\_METEO=[text]                   O     Name of the default SDS file containing the meteo data for all quantities, not yet implemented.
- EXP\_METEO=[text]                 O     Name of the meteo experiment, not yet implemented.

**2.7.9.1 AIR\_TEMP**

**Explanation:**

- TUNIT=[text]                   O     Name of the air temperature unit to display in, eg. degrees Celcius (°C).
- T\_AIR=[val]                    D     Background air temperature in degrees Celcius. The air temperature is a constant value. Default=20 °C
- SERIES=[text]                 O     SERIES can have two possible values: 'regular' or 'irregular'. When SERIES = 'regular' keywords FRAME and VALUES are expected. When SERIES = 'irregular' keyword TIME\_AND\_VALUES is expected.
- FRAME=[val1] [val2] [val3]   O     [val1] is the first time for which air temperature is given. [val2] is the time interval at which air temperature is given. [val3] is the last time at which air temperature is given. (All these times are given in minutes)
- VALUES=[val]                 O     The values for air temperature (dimension: See TUNIT) are given for the times as defined at the keyword frame.
- TIME\_AND\_VALUES=[tval] [val] O     In this case it is possible to give air temperature at non-equidistant times.
- USE\_METEO\_SDS                 D     Keyword refers to general meteo SDS.
- SDS\_AIR\_TEMP                 O     Keyword refers to the name of the specific SDS data, not yet implemented.
- EXP\_AIR\_TEMP                 O     Keyword refers to the name of the specific experiment, not yet implemented.

### 2.7.9.2 HUMIDITY

#### Explanation:

HUNIT= <i>[text]</i>	O	Name of the humidity unit to display. The maximum length of text is 4 characters.
R_HUMIDITY= <i>[val]</i>	D	Percentage of humidity (ranges between 0 and 100%) is a constant value. Default=73.4.
SERIES= <i>[text]</i>	O	SERIES can have two possible values: 'regular' or 'irregular'. When SERIES = 'regular' keywords FRAME and VALUES are expected. When SERIES = 'irregular' keyword TIME_AND_VALUES is expected.
FRAME= <i>[val1] [val2] [val3]</i>	O	<i>[val1]</i> is the first time for which humidity is given. <i>[val2]</i> is the time interval at which humidity is given. <i>[val3]</i> is the last time at which humidity is given. (All these times are given in minutes)
VALUES= <i>[val]</i>	O	The values for humidity (dimension: See HUNIT) are given for the times as defined at the keyword frame.
TIME_AND_VALUES= <i>[tval][val]</i>	O	In this case it is possible to give humidity at non-equidistant times.
USE_METEO_SDS	D	Keyword refers to general meteo SDS.
SDS_HUMIDITY	O	Keyword refers to the name of the specific meteo SDS data, not yet implemented.
EXP_HUMIDITY	O	Keyword refers to the name of the specific meteo experiment, not yet implemented.

### 2.7.9.3 CLOUD\_COVER

#### Explanation:

CUNIT= <i>[text]</i>	O	Name of the cloud covering unit to display. The maximum length of text is 4 characters.
T_CLOUD_COVER= <i>[val]</i>	D	Percentage of cloud covering (ranges between 0 and 100%) is a constant value. Default=34
SERIES= <i>[text]</i>	O	SERIES can have two possible values: 'regular' or 'irregular'. When SERIES = 'regular' keywords FRAME and VALUES are expected. When SERIES = 'irregular' keyword TIME_AND_VALUES is expected.

FRAME=[ <i>val1</i> ] [ <i>val2</i> ] [ <i>val3</i> ]	O	[ <i>val1</i> ] is the first time for which cloud covering is given. [ <i>val2</i> ] is the time interval at which cloud covering is given. [ <i>val3</i> ] is the last time at which humidity is given. (All these times are given in minutes)
VALUES=[ <i>val</i> ]	O	The values for cloud covering (dimension: See CUNIT) are given for the times as defined at the keyword frame.
TIME_AND_VALUES=[ <i>tval</i> ][ <i>val</i> ]	O	In this case it is possible to give cloud covering at non-equidistant times.
USE_METEO_SDS	D	Keyword refers to general meteo SDS.
SDS_HUMIDITY	O	Keyword refers to the name of the specific meteo SDS data, not yet implemented.
EXP_HUMIDITY	O	Keyword refers to the name of the specific meteo experiment, not yet implemented.

#### 2.7.9.4 SOLAR\_IRRADIATION

##### Explanation:

SUNIT=[ <i>text</i> ]	O	Name of the solar irradiation unit to display. The maximum length of text is 4 characters.
S_SOLAR=[ <i>val</i> ]	D	Solar irradiation in $W/m^{-2}$ . Solar radiation is a constant value. Default=50.0
SERIES=[ <i>text</i> ]	O	SERIES can have two possible values: 'regular' or 'irregular'. When SERIES = 'regular' keywords FRAME and VALUES are expected. When SERIES = 'irregular' keyword TIME_AND_VALUES is expected.
FRAME=[ <i>val1</i> ] [ <i>val2</i> ] [ <i>val3</i> ]	O	[ <i>val1</i> ] is the first time for which solar radiation is given. [ <i>val2</i> ] is the time interval at which solar radiation is given. [ <i>val3</i> ] is the last time at which solar radiation is given. (All these times are given in minutes)
VALUES=[ <i>val</i> ]	O	The values for solar radiation (dimension: See SUNIT) are given for the times as defined at the keyword frame.
TIME_AND_VALUES=[ <i>tval</i> ][ <i>val</i> ]	O	In this case it is possible to give solar irradiation at non-equidistant times.
USE_METEO_SDS	D	Keyword refers to general meteo SDS.
SDS_HUMIDITY	O	Keyword refers to the name of the specific meteo SDS data, not yet implemented.
EXP_HUMIDITY	O	Keyword refers to the name of the specific meteo experiment, not yet implemented.

### 2.7.10 TIDAL\_FORCES (optional)

In this section the tidal forces can be taken into account. This option only can be used together with a spherical or spherical / curvilinear grid. The tidal forces are computed by an implementation of prof. E.J.O. Schrama. The number of included tidal lines can be specified by changing the starting and stopping Doodson numbers or the tolerance level eps.

#### TIDAL\_FORCES

SCHRAMA

DOODSON\_START = [val]

DOODSON\_STOP = [val]

EPS = [val]

#### Explanation:

SCHRAMA	M	Only if this flag keyword is specified, the tidal forces are included.
DOODSON_START=[val]	D	Doodson number where the CTE summation starts. Default = 55.565
DOODSON_STOP=[val]	D	Doodson number where the CTE summation stops. Default = 375.575
EPS=[val]	D	Tolerance level for the used formula. Tidal harmonic amplitudes $H(v)$ are only included when $ H(v)  \geq \text{eps}$ . Default = 0.0

- Notes:
- The tidal forces will be given on the same type of grid as the grid used in WAQUA.
  - The tidal forces are gradients that are computed numerically based on the tidal potentials.

## 2.8 FLOW (mandatory)

In FLOW all information for the hydrodynamics-model used is given. This section is divided in three subsections:

### FLOW

PROBLEM

FORCINGS

CHECKPOINTS

### 2.8.1 PROBLEM (mandatory)

In this subsection the coefficients and parameters defining the model are given. PROBLEM is divided in nine subsections:

#### PROBLEM

TIMEFRAME

METHODVARIABLES

SMOOTHING

DRYING

FRICITION

VISCOSITY

HOR\_VISCOSITY

BARRIERCOEFFICIENTS

DISCHARGECOEFF

WEIRS

VELOCITY\_PROFILE

VERT\_CHEZY

#### 2.8.1.1 TIMEFRAME (mandatory)

In this subsection the start and end time of the simulation are given.

##### TIMEFRAME

DATE = *[text]*

TSTART = *[val]*

TSTOP = *[val]*

TIMEZONE = *[text]*

SUMMERTIME

#### **Explanation:**

DATE= <i>[text]</i>	M	Reference date in the form <i>dd mmm yyyy</i> , e.g. 12 oct 1987. <i>mmm</i> can be: jan, feb, mar, apr, may, jun, jul, aug, sep, oct, nov, dec. Midnight starting this date is time zero for a simulation. Times in minutes, such as TSTART, are elapsed minutes from midnight beginning the simulation start date.
TSTART= <i>[val]</i>	D	Start time of the simulation in elapsed minutes from midnight at the beginning of the simulation start date. It is advised to keep TSTART between 0 and 1440 minutes. Default = 0.0
TSTOP= <i>[val]</i>	M	End time of the simulation in elapsed minutes from midnight at the beginning of the simulation start date.
TIMEZONE=	O	Timezone indicator. Sustained values: “UNKNOWN”, “MET” and “GMT”. When this optional keyword is omitted, program assumes “UNKNOWN”.
SUMMERTIME	D	Summertime indicator. Default: wintertime.

### 2.8.1.2 METHODVARIABLES (mandatory)

In this subsection numeric method variables are defined.

#### METHODVARIABLES

TSTEP *[val]*  
CHECKCONT = *[text]*  
ITERCON = *[ival]*  
ITERMOM = *[ival]*  
ITERACCURWL = *[val]*  
ITERACCURVEL = *[val]*  
THETA = *[val]*  
QUANTF\_RANDOM  
CONSERVATIVE\_ADVECTION  
THREED\_BOTTOM  
RELAX\_BAR

#### **Explanation:**

TSTEP=[ <i>val</i> ]	M	<p>Time step used in the computation (minutes). It is advised that a time step is chosen that can be represented binary, e.g. 1/2, 1/8, 3/32, etc.</p>
CHECKCONT=[ <i>text</i> ]	D	<p>Type of convergence criterium for the continuity equation. This criterium will be based on flow velocities if [<i>text</i>] starts with the characters 'vel' (velocities, case insensitive), or it will be based on the waterlevels if [<i>text</i>] starts with the characters 'wl' (waterlevels, case insensitive).</p> <p>The check on waterlevels is cheaper in terms of the number of iterations required, especially in 3D (TRIWAQ) computations. On the other hand, for accuracy reasons, the check on velocity is advisable.</p> <p>Default = 'vel'.</p> <p>Note: in the sequential version of WAQUA/TRIWAQ (up to export 2000-01) the only available criterium was 'vel'.</p>
ITERCON=[ <i>ival</i> ]	D	<p>Maximum number of iterations for the continuity equation. The number of iteration steps that actually occurred depends on this constant and the iteration accuracy. Limitation: <math>ITERCON \geq 2</math>.</p> <p>Default = 8 (recommended in conjunction with an ITERACCURVEL of 0.005). The recommended value for accurate transport computation (ITERACCURVEL = 0.001) is 16.</p>
ITERMOM=[ <i>ival</i> ]	D	<p>Maximum number of iterations for the momentum equation in 2D and 3D computations.</p> <p>Default = 8.</p> <p>Note: Depending on the values of ITERACCURVEL / ITERACCURWL (especially for parallel runs with horizontal domain decomposition when (one of) these values are chosen smaller than the default) it may be advisable to set ITERMOM to a larger number than the default (= 8).</p> <p>E.g:</p> <p style="margin-left: 40px;">iteraccurvel = 0.0025 – itermom <math>\geq</math> 8</p> <p style="margin-left: 40px;">iteraccurwl = 0.00025 – itermom <math>\geq</math> 12</p>
ITERACCURVEL=[ <i>val</i> ]	M	<p>Convergence criterium for flow velocities in momentum equation and for continuity equation in case CHECKCONT = 'vel'</p>



ITERACCURWL= <i>[val]</i>	O	<p>The standard value is 0.005. The recommended value for accurate transport computation is 0.001.</p> <p>Convergence criterium for waterlevels in continuity equation in case CHECKCONT = 'wl'.</p> <p>The standard value is 0.002. The recommended value for accurate transport computation is 0.0005.</p> <p>If CHECKCONT = 'wl' then this value must be given.</p>
THETA= <i>[val]</i>	D	<p>Coefficient for Euler implicit (THETA=1) or central (THETA=0.5) time integration of the vertical terms in the momentum equation. Meaningful only in TRIWAQ.</p> <p>Default = 0.5</p>
QUANTF_RANDOM	D	<p>QUANTF_RANDOM is a flag keyword. Option to quantify the effects of round-off error on the simulation results.</p> <p>Due to the finite precision by which real numbers are represented by a computer, a simulation with WAQUA/TRIWAQ requires constant rounding off of intermediate results by the computer, which eventually affects the accuracy of the computed simulation results. The extent by which the simulation results are affected may be examined by using this option. The option activates a second implementation for a specific computation in WAQUA/TRIWAQ which results in a different pattern of round-off errors. Compare the results of a simulation run with this option to those of a run without the modification in order to see the potential effect of round-off errors and other seemingly small disturbances on the simulation results.</p> <p>Default = no quantification.</p>
CONSERVATIVE_ADVECTION	D	<p>CONSERVATIVE_ADVECTION is a flag keyword. If this keyword is specified, then a conservative discretisation for advection is used.</p> <p>Default = no conservative advection.</p>
THREED_BOTTOM	D	<p>THREED_BOTTOM is a flag keyword. If this keyword is specified, then the vertical velocity is used in the computation of the bottom drag. Default = no threed_bottom.</p>

RELAX\_BAR

D RELAX\_BAR is a relaxation for the barrier discharge. It must be positive and less than one. When relaxation is used (RELAX\_BAR>0), the barrier velocity is a weighted average of the velocity necessary for the correct barrier discharge and the velocity in the previous (half) timestep. Default = 0 (no relaxation).

Recommended- / standard values, (D) = default:

checkcont	transport	iteraccurvel	iteraccurwl	itercon	itermom
empty /'vel'	no	0.005	n/a	8 (D)	8 (D)
empty /'vel'	yes	0.001	n/a	16	8 (D)
'wl'	no	0.005	0.002	8 (D)	8 (D)
'wl'	yes	0.001	0.0005	16	8 (D)

Recommendations:

- To check the convergence of the solution of the continuity equation, use CHECKCONT ('vel' or 'wl'); 'vel'-check was exclusively used in the sequential version of WAQUA/TRIWAQ (up to export 2000-01).
- Keyword ITERACCURVEL should always be specified:
  - no transport: 0.005 (ITERCON = 8)
  - with transport: 0.001 (ITERCON =16)
- Keyword ITERACCURWL should only be specified when CHECKCONT = 'wl':
  - no transport: 0.002 (ITERCON = 8)
  - with transport: 0.0005 (ITERCON = 16)
- Keyword ITERCON: 8 / 16 (transport no /yes).
- Keyword ITERMOM: use default = 8.

### 2.8.1.3 SMOOTHING

A relatively smooth start-up of the simulation can be obtained as follows:

#### SMOOTHING

TLSMOOTH = [val]  
OLD\_SMOOTHING

#### Explanation:

TLSMOOTH=[val]

- D Is the last time (in elapsed minutes after midnight at the beginning of the simulation start date) for interpolation between initial condition and the boundary condition at time TLSMOOTH at open boundaries. During the initial period (TLSMOOTH - TSTART) the initial water levels and velocities, and the open boundary levels or velocities are interpolated to obtain a relatively smooth “start-up” of the simulation.

Caution: at restarts, when restart-time is before TLSMOOTH, this may cause unexpected changes in results, due to a different smoothing period in the several runs. In this case the TLSMOOTH value in the restart run has to be equal to the original value in the base run.

Default = 0.0

OLD\_SMOOTHING

- D OLD\_SMOOTHING is a flag keyword. If this keyword is specified, then a linear interpolation between the initial condition and the boundary condition is used during the initial period (TLSMOOTH-TSTART). If this keyword is not specified then a ramp function based on a tanh-function is used which gives a smoother start-up than linear interpolation.

Default = smoothing using the tanh ramp function (i.e. no old\_smoothing).

### 2.8.1.4 DRYING (optional)

In this subsection the parameters for the drying and flooding method in the model is given.

See also:

Memo EV/M04.100, 2004

Erik de Goede (Deltares), Edwin Vollebregt and Bas van 't Hof (VORtech Computing).

**DRYING**

CHECK\_WL = 'YES' | 'NO'  
TRESH\_UV\_FLOODING = [val]  
TRESH\_WL\_FLOODING = [val]  
DEPCRIT = [val]  
UPWIND\_ZETA = 'YES' | 'NO'

**Explanation:**

CHECK\_WL=[text]   D         Flag for drying control at water level point.  
Default = 'YES'

Note: In previous versions CHECK\_WL='NO' corresponded to IDRYFLAG=3.

THRES\_UV\_FLOODING=[val]                                D         Threshold value for drying/flooding checks  
at velocity points (m).  
Default = 0.3

THRES\_WL\_FLOODING=[val]                            D         Threshold value for drying/flooding checks  
at water level points (m).  
default = the value of  
THRES\_UV\_FLOODING

DEPCRIT=[val]                                        D         Marginal depths in tidal flats (m).  
Default = 0.3

Notes: - DEPCRIT is only still operational because of compatibility reasons. The user is  
advised to apply keyword THRES\_UV\_FLOODING.  
- If THRES\_UV\_FLOODING is used, then keyword DEPCRIT is neglected.

UPWIND\_ZETA=[text]                                   D         Flag for upwinding for the computation of  
the water elevation at velocity points.  
Default = 'NO'

In general:

- Drying control at velocity-location always takes place.
- In order to get smooth flooding behaviour the computation should be started at high water.

- See also section 3.6 of this User's Guide WAQUA: General information.

### 2.8.1.5 FRICTION (mandatory)

This section has six subsections

#### FRICTION

##### GLOBAL

##### UDIREC

##### VDIREC

##### NIKURADSE

##### ROUGHCOMBINATION

##### FRICOMBINATION

First direction-independent global data is given in subsection GLOBAL. In the subsections UDIREC and VDIREC global and local spatial values can be given for u- and v-direction. Local values can be defined in the BOX format. The layout for the data under UDIREC and VDIREC is in conformity with data fields (par. 2.1.2).

### GLOBAL (mandatory)

In this subsection direction-independent information concerning the computation of the Chezy values is given.

#### GLOBAL

TICVAL = *[val]*

FORMULA = *[text]*

### Explanation:

TICVAL=*[val]*

D Time interval to compute Chézy values from given friction-values. (minutes)  
Default = 1.0

Note: The program will check whether the given time interval is a multiple of the time step of the simulation (TSTEP). If necessary, the time interval will be corrected to fulfil this condition. For a positive number of weirs the time interval will always be reduced to TSTEP. When TICVAL is set to zero (either explicitly or by the program), Chézy calculations will **not** be performed.

FORMULA=[text]

- o Name of the used formula for friction. 'Manning', 'White-Colebrook', 'Chezy', 'Z0-based' and 'Linear' are available. Refer to 'General Information' (Section 1) of this User's Guide WAQUA: About WAQUA.  
Default: 'Manning'

The dimension of the friction-values in this section depends on the chosen formula for friction:

The 'Manning' formula requires the 'Manning's parameter' with dimension  $m^{-1/3}s$ .

The 'White-Colebrook' formula requires the 'White-Colebrook parameter' with dimension m(eter).

The 'Chezy' formula requires the 'Chézy friction coefficient' with dimension  $m^{1/2}/s$ .

The 'Linear' formula requires the 'Linear friction parameter' with dimension  $m/s$ .

Notes: - By introducing zero values the user may create screens.

- The 'Z0-based' friction method is available only in TRIWAQ. It can be used only in the combination with the parabolic vertical viscosity profile (see Sections 2.8.1.10 and 2.14.2 for more information).

If weirs are specified, the 'Z0-based' bottom friction method is not allowed.

The keywords UDIREC and VDIREC are not used in case of a Z0-based bottom friction. For a Z0-based friction method keyword ZZERO (see subsection 2.8.1.10) should be used.

The "Linear friction" method may not be used in combination with 'Chezy correction'. Further more the method may only be used if there is 1 layer only and it cannot be used together with 'friction combination method' (keyword FRICOMBINATION).

## UDIREC (mandatory)

Friction coefficients or parameters at U locations can be defined here. Section UDIREC has two subsections:

UDIREC

GLOBAL

LOCAL

The layout and defaults for subsections GLOBAL and LOCAL are described in paragraph

## 2.1.2 (Data fields).

**VDIREC (mandatory)**

Friction coefficients or parameters at V locations can be defined here. Section VDIREC has two subsections:

VDIREC  
GLOBAL  
LOCAL

The layout and defaults for subsections GLOBAL and LOCAL are described in paragraph 2.1.2 (Data fields).

**NIKURADSE (optional)**

In this subsection information concerning the k-Nikuradse computation is given.

The Nikuradse option is only available in combination with the White-Colebrook roughness method.

NIKURADSE  
GLOBAL  
TIMES  
TFNIKU = [val]      TINIKU = [val]      TLNIKU = [val]  
ROUGH\_CHAR  
<R\_CODE = [ival]      A = [val]      B = [val]      C = [val]      D = [val]      >  
UDIREC  
AREAU = [text]  
VDIREC  
AREAV = [text]

When the subsection NIKURADSE is given its subsections GLOBAL, TIMES, UDIREC and VDIREC are mandatory.

The subsection ROUGH\_CHAR is optional.

**Explanation:**

<u>TFNIKU</u> = [val]	O	Time to do the first k-Nikuradse computation.
<u>TINIKU</u> = [val]	M	Time interval for the k-Nikuradse computation.
<u>TLNIKU</u> = [val]	D	Time to do the last k-Nikuradse computation.

(All times in elapsed simulation minutes)

<i>R_CODE=[ival]</i>	M	<p>Roughness code. Only values between 1 and 999 are valid. The following codes (on head points) are defined (see for detailed codes Table "Relations between Rcode, A and B" under Notes).</p> <table border="0" style="margin-left: 20px;"> <thead> <tr> <th style="text-align: left;">R_CODE</th> <th style="text-align: left;">Meaning</th> </tr> </thead> <tbody> <tr> <td>1</td> <td>code for buildings</td> </tr> <tr> <td>2</td> <td>code for water free surface</td> </tr> <tr> <td>3</td> <td>default k-Nikuradse value</td> </tr> <tr> <td>4-400</td> <td>code for roughness with a static k-Nikuradse value</td> </tr> <tr> <td>401-700</td> <td>code for roughness for the main-channel</td> </tr> <tr> <td>701-950</td> <td>code for vegetation structure types with a k-Nikuradse value depending from the water depth</td> </tr> <tr> <td>951-999</td> <td>code for hedges and wooden banks</td> </tr> </tbody> </table>	R_CODE	Meaning	1	code for buildings	2	code for water free surface	3	default k-Nikuradse value	4-400	code for roughness with a static k-Nikuradse value	401-700	code for roughness for the main-channel	701-950	code for vegetation structure types with a k-Nikuradse value depending from the water depth	951-999	code for hedges and wooden banks
R_CODE	Meaning																	
1	code for buildings																	
2	code for water free surface																	
3	default k-Nikuradse value																	
4-400	code for roughness with a static k-Nikuradse value																	
401-700	code for roughness for the main-channel																	
701-950	code for vegetation structure types with a k-Nikuradse value depending from the water depth																	
951-999	code for hedges and wooden banks																	
<i>A=[val]</i>	M	<p>The meaning of A depends on the value of R_CODE:</p>																



R_CODE	Meaning
1	A has no meaning
2	A has no meaning
3	A is the default k-Nikuradse value
4-400	A is the k-Nikuradse value
401-700	A is alfa in the formula for roughness of the main channel (see formula in User's guide WAQUA, General Information, subsection 3.4.2.5)
701-950	A is the value for vegetation height in the formula for roughness of vegetation structure types (see formula in User's guide WAQUA, General Information, subsection 3.4.2.5)
951-999	A is the value for the height of the hedges in the formula for roughness of hedges (see formula in User's guide WAQUA, General Information, subsection 3.4.2.5)

$B=[val]$

- The meaning of B depends on the value of R\_CODE:

	R_CODE	Meaning
	1	B has no meaning
	2	B has no meaning
	3	B has no meaning
	4-400	B is the k-Nikuradse value
	401-700	B is beta in the formula for roughness of the main channel (see formula in User's guide WAQUA, General Information, subsection 3.4.2.5)
	701-950	B is the value for vegetation density in the formula for roughness of vegetation structure types (see formula in User's guide WAQUA, General Information, subsection 3.4.2.5)
	951-999	A is the value for the density of the hedges in the formula for roughness of hedges (see User's guide WAQUA, General Information, 3.4.2.5)
<i>c=[val]</i>	D	C is a multiplication factor for A. C is only meaningful in case A is meaningful. C will be used in cases of calibration. Default = 1.0
<i>d=[val]</i>	D	D is a multiplication factor for B. D is only meaningful in case B is meaningful. D will be used in cases of calibration. Default = 1.0
<i>AREAU=[text]</i>	M	Area-U tablename. The given filename can contain an explicit pathname. The use of any indication of a parent directory ('..') is allowed.
<i>AREAV=[text]</i>	M	Area-V tablename (see Area-U for the filename).

Notes: - the Area-U and V-table must contain formatted records (format 3I6, F10.0). Each of these records successively contains:

N-grid index (I6)

M-grid index (I6)

roughness code (I6)

fraction (F10.0)

The data records for cell (m,n) must be entered consecutively.

Valid fractions in the AREAU and AREAV tables for r\_codes 1-950 are between 0.0 and 1.0. Also the total fraction for cell (m,n) may not exceed 1.0 as far the r-codes 1 - 950 are concerned.

R_code	Fraction		Description
	min	max	
1-950	0.	1.	Fraction of the gridcell covered by this (r_code) roughness type
951-999	0.	-	Relative length of this roughness type (r_code) in this gridcell. For example if two hedges with the same r_code going from one side to the other side of this gridcell then the fraction should be 2. The relative length is a projection of the line on the middle of the gridcell. One and other depends on the U or V direction.

- Table “Relations between Rcode, A and B”

Rcode	A			B			Description
	def	min	max	def	min	max	
1							
2							
3	0.2	0.05	1.0				default k-Nikuradse
11	0.05	0.05	11.0				open water (not the main-channel)
16	0.25	0.05	1.0				groyne section or shore line
21	0.2	0.1	0.3				smooth grassland
26	0.5	0.15	0.75				normal grassland
27	0.4	0.05	10.0				arable land
31	0.75	0.25	1.5				rough grassland
36	1.0	0.5	5.0				open herbaceous (winter)
41	0.2	0.1	0.5				dense herbaceous (winter)
51-100	0.6	0.01	100.0				fixed layers
101-200	5.0	0.01	100.0				Villages
201-400	0.2	0.01	100.0				user definable k-Nikuradse
401	0.1	0.01	0.5	2.5	1.0	10.0	main-channel

402-700	0.1	0.01	0.5	2.5	1.0	10.0	user definable main-channel
701	6.0	6.0	40.0	0.005	0.0005	0.01	open forest
706	6.0	6.0	40.0	0.025	0.01	0.03	normal forest
711	6.0	6.0	20.0	0.05	0.03	0.06	dense forest
716	4.0	4.0	6.0	0.1	0.03	0.3	shrubs
721	1.0	0.2	4.0	0.13	0.03	0.3	open herbaceous (summer)
726	2.0	0.2	4.0	0.5	0.3	1.0	normal herbaceous
731	2.0	0.2	4.0	2.5	0.5	10.0	dense herbaceous (summer)
736	2.0	0.2	4.0	1.0	0.5	10.0	reed
751-900	4.0	0.2	40.0	0.1	0.0005	10.0	user definable vegetation structure types
901	6.0	6.0	40.0	0.01	0.0005	1.0	tree lane
906-950	6.0	0.2	40.0	0.01	0.0005	1.0	user definable tree lanes
951	2.0	0.2	3.0	1.5	0.1	16.0	hedges
956	5.0	3.0	6.0	1.25	0.1	16.0	wooded bank
961-999	3.0	0.2	6.0	1.5	0.1	16.0	user definable hedges and wooded banks

The program will check the value for A and B if it fits between the minimum and the maximum after the multiplication with C and D. For r-codes between 401 and 999 the program needs the water-depth for the calculation of the k-Nikuradse values. Waterdepths lower than a minimum depth will be replaced (only for the k-Nikuradse calculation) by this minimum. The minimum water depth is 0.25 meter.

Note: TICVAL (interval for Chezy computation) must have a value by which each k-Nikuradse computation is followed by a Chezy computation.

## ROUGHCOMBINATION (optional)

In this subsection information concerning the Roughcombination computation is given.

With the Roughcombination method it is possible to combine several roughness methods at fractions per gridcell. The input for these fractions per gridcell and which roughness method must be used is given in the area files.

It is possible to specify steering parameters for the roughness values. This can be achieved by specifying the roughness code in the section ROUGH\_PARAMETER. For each specified roughness code in this section it is mandatory to specify if a waterlevel in a point or a discharge in a curve is used for steering. The actual roughness values will be given in section ROUGH\_CHAR. If a roughness code was specified in ROUGH\_PARAMETER then it is possible to specify more than one steering value. These steering values can be specified under PARAMETER in section ROUGH\_CHAR.

If for a roughness code multiple parameter values are given, then the actual roughness values will be linear interpolated if the actual value of the waterlevel or discharge is between two given parameters. If the actual value of the waterlevel or the discharge is above the highest or below the lowest given parameter value, constant extrapolation of the roughness values

corresponding to the highest or lowest parameter value are used, respectively.

Some rules must be taken into account for using parameter steered roughness codes:

- In section ROUGH\_PARAMETER the roughness codes must be specified in increasing order.
- In section ROUGH\_PARAMETER each roughness code can only be specified once.
- For each specified roughness code it is mandatory to choose either a waterlevel or a discharge as a steering parameter. If WATERLEVEL is used it is mandatory to specify the corresponding point. If DISCHARGE is used it is mandatory to specify the corresponding curve.
- Each specified point must be a point from the section POINTS and should also be specified as under LEVELSTATIONS in section CHECKPOINTS.
- Each specified curve must be a curve from the section CURVES and should also be specified under a USECTIONS or VSECTIONS in section CHECKPOINTS.
- If a roughness code is specified in section ROUGH\_PARAMETER, it should also be given in section ROUGH\_CHAR **with** a parameter value.
- If a parameter is given in section ROUGH\_CHAR for a roughness code, then this code must also be specified in section ROUGH\_PARAMETER.
- It is not allowed to specify roughness values for a roughness code with and without a parameter value in section ROUGH\_CHAR.
- Per roughness code where multiple parameter values are used, these parameter values must be given in increasing order.

The following roughness methods may be combined: the White-Colebrook formula, the Manning formula, a static Chezy value, the roughness method for the main channel of a river, buildings and vegetation (area 's, lines and points). Except for the last two it is also possible for the user to use different roughness values for increasing and decreasing waterlevels (ebb and flood).

For more information about the used formula's see User's guide WAQUA, General Information, subsection 3.4.2.6

#### ROUGHCOMBINATION

##### GLOBAL

##### TIMES

TFROUC = [val]      TIROUC = [val]      TLROUC = [val]

##### ROUGH\_PARAMETER

| <R\_CODE = [ival]      WATERLEVEL      P [ival]>

<

| <R\_CODE = [ival]      DISCHARGE      C [ival]>

##### ROUGH\_CHAR

```

    <R_CODE [ival]  PARAMETER [val]  A [val] B [val] C [val] D [val] >
UDIREC
    AREAU = [text]
VDIREC
    AREAV = [text]

```

When the subsection ROUGHCOMBINATION is given its subsections GLOBAL, TIMES, UDIREC and VDIREC are mandatory.

The subsections ROUGH\_PARAMETER and ROUGH\_CHAR are optional, however, the restrictions mentioned above apply.

**Explanation:**

TFROUC= <i>[val]</i>	O	Time to do the first Roughcombination computation.
TIROUC= <i>[val]</i>	M	Time interval for the Roughcombination computation.
TLROUC= <i>[val]</i>	D	Time to do the last Roughcombination computation.

(All times in elapsed simulation minutes)

R_CODE= <i>[ival]</i>	M	Roughness code. In general values between 1 and 1999 are valid. In more detail the following codes are defined (see for defaults, minima and maxima per code Table "Relations between Rcode, A, B, C and D" under Notes).
-----------------------	---	---

	R_CODE	Meaning
	1-50	code for buildings and water free surface
	51-100	not defined
	101-300	code for roughness with a static k-Nikuradse value used in the White-Colebrook formula
	301-500	code for roughness with a static k-Manning value used in the Manning formula
	501-600	code for roughness with a static Chezy value
	601-900	code for roughness for the main-channel
	901-1200	not defined
	1201-1400	code for vegetation structure types (area's, like grass)
	1401-1500	not defined
	1501-1600	code for vegetation structure types (points, like trees)
	1601-1700	code for vegetation structure types (lines, like hedges)
	1701-1800	not defined
	1801-1999	code for combinations of roughness area's
WATERLEVEL	O	If WATERLEVEL is specified, the roughness values A, B, C and D are calculated with the waterlevel in the specified point as a steering parameter.
P=[ival]	M	The waterlevel in this point is used as a steering parameter for calculation of the roughness values A, B, C and D for the corresponding roughness code. This keyword is mandatory if the keyword WATERLEVEL is specified.
DISCHARGE	O	If DISCHARGE is specified, the roughness values A, B, C and D are calculated with the discharge in the specified curve as a steering parameter.
c=[ival]	M	The discharge in this curve is used as a steering parameter for calculation of the roughness values A, B, C and D for the corresponding roughness code. This keyword is mandatory if the keyword DISCHARGE is specified.

PARAMETER=[ <i>val</i> ]	M	Values for the steering parameter, which can be either a waterlevel in meters or a discharge in cubic meters per second. During the simulation these values are used to calculate the real roughness values by linear interpolation or constant extrapolation of the corresponding A, B, C and D values.																				
A=[ <i>val</i> ]	M	<p>The meaning of A depends on the value of R_CODE:</p> <table border="0" style="margin-left: 20px;"> <thead> <tr> <th style="text-align: left;">R_CODE</th> <th style="text-align: left;">Meaning</th> </tr> </thead> <tbody> <tr> <td>1-50</td> <td>A has no meaning</td> </tr> <tr> <td>101-300</td> <td>A is the k-Nikuradse value (normal or ebb)</td> </tr> <tr> <td>301-500</td> <td>A is the k-Manning value (normal or ebb)</td> </tr> <tr> <td>501-600</td> <td>A is the Chezy value (normal or ebb)</td> </tr> <tr> <td>601-900</td> <td>A is alfa in the formula for roughness of the main channel (normal or ebb)</td> </tr> <tr> <td>1201-1400</td> <td>A is the value for vegetation height in the formula for roughness of vegetation structure types</td> </tr> <tr> <td>1501-1600</td> <td>A is the value for vegetation height in the formula for roughness of individual trees</td> </tr> <tr> <td>1601-1700</td> <td>A is the value for the height of the hedges in the formula for roughness of hedges</td> </tr> <tr> <td>1801-1999</td> <td>A is the r_code for the first roughness combination.</td> </tr> </tbody> </table>	R_CODE	Meaning	1-50	A has no meaning	101-300	A is the k-Nikuradse value (normal or ebb)	301-500	A is the k-Manning value (normal or ebb)	501-600	A is the Chezy value (normal or ebb)	601-900	A is alfa in the formula for roughness of the main channel (normal or ebb)	1201-1400	A is the value for vegetation height in the formula for roughness of vegetation structure types	1501-1600	A is the value for vegetation height in the formula for roughness of individual trees	1601-1700	A is the value for the height of the hedges in the formula for roughness of hedges	1801-1999	A is the r_code for the first roughness combination.
R_CODE	Meaning																					
1-50	A has no meaning																					
101-300	A is the k-Nikuradse value (normal or ebb)																					
301-500	A is the k-Manning value (normal or ebb)																					
501-600	A is the Chezy value (normal or ebb)																					
601-900	A is alfa in the formula for roughness of the main channel (normal or ebb)																					
1201-1400	A is the value for vegetation height in the formula for roughness of vegetation structure types																					
1501-1600	A is the value for vegetation height in the formula for roughness of individual trees																					
1601-1700	A is the value for the height of the hedges in the formula for roughness of hedges																					
1801-1999	A is the r_code for the first roughness combination.																					
B=[ <i>val</i> ]	O	The meaning of B depends on the value of R_CODE:																				



		R_CODE	Meaning
		1-50	B has no meaning
		101-300	B is the k-Nikuradse value (flood)
		301-500	B is the Manning value (flood)
		501-600	B is the Chezy value (flood)
		601-900	B is beta in the formula for roughness of the main channel (normal or ebb)
		1201-1400	B is the value for vegetation density in the formula for roughness of vegetation structure types
		1501-1600	B is the drag coefficient value in the formula for roughness of individual trees
		1601-1700	B is the value for the density of the hedges in the formula for roughness of hedges
		1801-1999	B is the r_code for the second roughness combination
<i>c=[val]</i>	D	The meaning of C depends on the value of R_CODE:	
		R_CODE	Meaning
		1-50	C has no meaning
		101-300	C has no meaning
		301-500	C has no meaning
		501-600	C has no meaning
		601-900	C is alfa in the formula for roughness of the main channel (flood)
		1201-1400	C is the value for the drag coefficient in the formula for roughness of vegetation structure types
		1501-1600	C has no meaning
		1601-1700	C is the value for the drag coefficient in the formula for roughness of hedges
		1801-1999	C is the percentage of the roughness type given at A. C and D together should be 1.0
<i>d=[val]</i>	D	The meaning of D depends on the value of R_CODE.	

		R_CODE	Meaning
		1-50	D has no meaning
		101-300	D has no meaning
		301-500	D has no meaning
		501-600	D has no meaning
		601-900	D is beta in the formula for roughness of the main channel (flood)
		1201-1400	D is the value for the k-Nikuradse coefficient for vegetation at the surface in the formula for roughness of vegetation structure types
		1501-1600	D has no meaning
		1601-1700	D is the value for the energy loss coefficient in the formula for roughness of hedges
		1801-1999	D is the percentage of the roughness type given at B, C and D together should be 1.0
AREAU=[text]	M		Area-U tablename. The given filename can contain an explicit pathname. The use of any indication of a parent directory ('..') is allowed.
AREAV=[text]	M		Area-V tablename (see Area-U for the filename).

Notes: - The Area-U and V-table must contain formatted records (format 3I6, F10.0). Each of these records successively contains:

- N-grid index (I6)
- M-grid index (I6)
- roughness code (I6)
- fraction (F10.0)

The data records for cell (m,n) must be entered **consecutively**.

- Valid fractions in the AREAU and AREAV tables for r\_codes 1-1600 and 1801-1999 are between 0.0 and 1.0. Also the total fraction for a gridcell (m,n) for the R\_CODE 1-1501 and 1801-1999 may not exceed 1.0.

The program will check the value for A, B, C and D if it fits between the minimum and the maximum

The program needs the waterdepth for the calculation of all roughness types except for the

Table 2.120: *R\_code Fraction Description*

	<b>min</b>	<b>max</b>	
<b>1-1501</b>	0.	1.	Fraction of the gridcell covered by this (r_code) roughness type
<b>1501-1600</b>	0.	1.	Vegetation density of the trees in this gridcell. The density is defined as the number of trees multiplied by the diameter of the trees and divided by the gridcell area
<b>1601-1700</b>	0.	-	Relative length of this roughness type (r_code) in this gridcell. For example if two hedges with the same r_code going from one side to the other side of this gridcell then the fraction should be 2. The relative length is a projection of the line on the middle of the gridcell.
<b>1801-1999</b>	0.	1.	Fraction of the gridcell covered by this (r_code) roughness type

static Chezy method. Waterdepths less than a minimum depth will be replaced by this minimum. The minimum water depth is 0.0001 meter.

If a gridcell is covered by 100 percent of water free surface the user may expect no stream velocity in such a gridcell. Unfortunately the program can not handle such a case perfectly. The program calculates a roughness for this gridcell with a maximum of 99.99 percent of the gridcell covered by the water free surface area which results in a very high roughness value. So the result in a Waqua calculation is a very weak stream velocity through this gridcell, but not necessarily zero. If the user actually wants no stream velocity at all then the user should use screens at such a location.

Each roughness type will result in a Chezy value for this roughness type. The Chezy value of each roughness type in one gridcell will be combined in one overall chezy value for this gridcell. The overall chezy value is constructed out of a parallel and serial chezy value with a theta value of 0.6 (see formula in User's guide WAQUA, General Information, subsection 3.4.2.6)

TICVAL (interval for Chezy computation) must have a value by which each Roughcombination computation is followed by a Chezy computation.

The default roughness method depends on the value given in FORMULA. This default roughness method is used in case the fraction of a gridcell is not covered for the full 100 percent of a roughness type. In such a case the remaining part of the gridcell will be filled with the default roughness method given at FORMULA and with the values given at the default roughness values (R\_CODE 101 or 301 or 501).

Note that for roughness codes 1801-1999 the A and B parameters may contain roughness codes in the same range; thus combinations of roughness combinations are allowed. However, the nesting is restricted to 10 levels.

Table 2.122: *Relations between Rcode, A, B, C and D*

<b>Rcode</b>	<b>Para- meter</b>	<b>Def</b>	<b>min</b>	<b>max</b>	<b>Description</b>
<b>101</b>	a	0.20	0.0001	100.	default k-Nikuradse (normal or ebb)
	b	0.20	0.0001	100.	default k-Nikuradse (flood)
<b>102-300</b>	a	0.20	0.0001	100.	k -Nikuradse (normal or ebb)
	b	0.20	0.0001	100.	k-Nikuradse (flood)
<b>301</b>	a	0.0263	0.001	100.	default Manning (normal or ebb)
	b	0.0263	0.001	100.	default Manning (flood)
<b>302-500</b>	a	0.0263	0.001	100.	Manning (normal or ebb)
	b	0.0263	0.001	100.	Manning (flood)
<b>501</b> hline	a	0.0263	0.001	100.	default Chezy (normal or ebb)
	b	0.0263	0.001	100.	default Chezy (flood)
<b>502-600</b>	a	0.0263	0.001	100.	Chezy (normal or ebb)
	b	0.0263	0.001	100.	Chezy (flood)
<b>601-900</b>	a	0.1	0.001	1.0	main-channel (normal or ebb)
	b	2.5	0.1	100.	main-channel (normal or ebb)
	c	0.1	0.001	1.0	main-channel (flood)
	d	2.5	0.1	100.	main-channel (flood)
<b>1201-1400</b>	a	0.2	0.001	50.	vegetation roughness for area's
	b	0.2	0.0001	100.	vegetation roughness for area's
	c	1.8	0.1	10.	vegetation roughness for area's
	d	0.2	0.001	100	vegetation roughness for area's
<b>1501-1600</b>	a	10.	0.5	50.	vegetation roughness individual trees
	b	1.5	0.1	10.	vegetation roughness individual trees
<b>1601-1700</b>	a	2.0	0.5	10.	vegetation roughness for hedges
	b	0.6	0.01	10.	vegetation roughness for hedges
	c	1.5	0.1	10.	vegetation roughness for hedges
	d	1.2	0.1	10	vegetation roughness for hedges
<b>1801-1999</b>	a	1221	1	1999.	combination vegetation roughness for area's
	b	106	1	1999.	combination vegetation roughness for area's
	c	0.75	0.001	0.999	combination vegetation roughness for area's
	d	0.25	0.001	0.999	combination vegetation roughness for area's

In section 2.19 an example of the input description is given. The values for the vegetation are related to the document “Stromingsweerstand van vegetatie in uiterwaarden” part one and part two Riza rapport 2003.028 and Riza rapport 2003.029 by E.H. van Velzen, P. Jesse, P. Cornelissen and H. Coops.

ROUGHCOMBINATION can not be combined with NIKURADSE or FRICOMBINATION.

## FRICOMBINATION (optional)

In this subsection information is given for the case that more than one roughness method in different locations is to be used and/or that different friction values are to be employed during flood, i.e. rising water level, and ebb (dropped water level), respectively.

### FRICOMBINATION

```

GLOBAL
  LAYOUT = [ival]
MANNING
  UFLOOD
<      BOX : MNMN = ([ival],[ival]) ([ival],[ival])
      | CONST_VALUES = [val]
      <
      | CORNER_VALUES = [val],[val],[val],[val]
      <
      | VARIABLE_VALUES = <[val]>
>
  UEBB
<      BOX : MNMN = ([ival],[ival]) ([ival],[ival])
      | CONST_VALUES = [val]
      <
      | CORNER_VALUES = [val],[val],[val],[val]
      <
      | VARIABLE_VALUES = <[val]>
>
  VFLOOD
<      BOX : MNMN = ([ival],[ival]) ([ival],[ival])
      | CONST_VALUES = [val]
      <
      | CORNER_VALUES = [val],[val],[val],[val]
      <
      | VARIABLE_VALUES = <[val]>
>
  VEBB
<      BOX : MNMN = ([ival],[ival]) ([ival],[ival])
      | CONST_VALUES = [val]
      <
      | CORNER_VALUES = [val],[val],[val],[val]
      <
      | VARIABLE_VALUES = <[val]>
>
  WHITE_COLEBROOK

```

```

    UFLOOD
<     BOX : MNMN = ([ival],[ival]) ([ival],[ival])
        | CONST_VALUES = [val]
        <
        | CORNER_VALUES = [val],[val],[val],[val]
        <
        | VARIABLE_VALUES = <[val]>
>
    UEBB
<     BOX : MNMN = ([ival],[ival]) ([ival],[ival])
        | CONST_VALUES = [val]
        <
        | CORNER_VALUES = [val],[val],[val],[val]
        <
        | VARIABLE_VALUES = <[val]>
>
    VFLOOD
<     BOX : MNMN = ([ival],[ival]) ([ival],[ival])
        | CONST_VALUES = [val]
        <
        | CORNER_VALUES = [val],[val],[val],[val]
        <
        | VARIABLE_VALUES = <[val]>
>
    VEBB
<     BOX : MNMN = ([ival],[ival]) ([ival],[ival])
        | CONST_VALUES = [val]
        <
        | CORNER_VALUES = [val],[val],[val],[val]
        <
        | VARIABLE_VALUES = <[val]>
>
    CHEZY
    UFLOOD
<     BOX : MNMN = ([ival],[ival]) ([ival],[ival])
        | CONST_VALUES = [val]
        <
        | CORNER_VALUES = [val],[val],[val],[val]
        <
        | VARIABLE_VALUES = <[val]>
>
    UEBB
<     BOX : MNMN = ([ival],[ival]) ([ival],[ival])
        | CONST_VALUES = [val]
        <
        | CORNER_VALUES = [val],[val],[val],[val]
        <
        | VARIABLE_VALUES = <[val]>
>
    VFLOOD
<     BOX : MNMN = ([ival],[ival]) ([ival],[ival])

```

```

      | CONST_VALUES = [val]
    <
      | CORNER_VALUES = [val],[val],[val],[val]
    <
      | VARIABLE_VALUES = <[val]>
  >
  VEBB
  <
    BOX : MNMN = ([ival],[ival]) ([ival],[ival])
      | CONST_VALUES = [val]
    <
      | CORNER_VALUES = [val],[val],[val],[val]
    <
      | VARIABLE_VALUES = <[val]>
  >

```

**Explanation:**

LAYOUT	D	See paragraph 2.1.2.1 Default = 1
MANNING	O	Under this section values for the MANNING method can be specified.
WHITE_COLEBROOK	O	Under this section values for the WHITE_COLEBROOK method can be specified.
CHEZY	O	Under this section values for the CHEZY method can be specified.
UFLOOD	M	Values for friction in the U-direction for flood.
VFLOOD	M	Values for friction in the V-direction for flood.
UEBB	O	Values for friction in the U-direction for ebb.
VEBB	O	Values for friction in the V-direction for ebb.
BOX	R	See paragraph 2.1.2.2
MNMN=( [ival], [ival] ) ( [ival], [ival] )	M	See paragraph 2.1.2.2
CONST_VALUES = [val]	O	See paragraph 2.1.2.2
VARIABLE_VALUES = < [val] >	O	See paragraph 2.1.2.2
CORNER_VALUES = [val], [val], [val], [val]	O	See paragraph 2.1.2.2

**Explanation:**

If keyword FRICOMBINATION is specified, at least one of the keywords CHEZY, MANNING or WHITE\_COLEBROOK has to be given. Each sub-keyword and subsequent block is employed to specify the method and the friction parameters for a number of boxes. The method is specified for each box in accordance with the sub-keyword used, i.e. MANNING, WHITE\_COLEBROOK or CHEZY. The flood and ebb values are specified next for the U-direction and for the V-direction as indicated by the subsub-keywords UFLOOD, UEBB, VFLOOD and VEBB, respectively.

- Notes:
- For each method specified, at least UFLOOD and VFLOOD have to be specified
  - If UEBB or VEBB are not specified, the values of UFLOOD and VFLOOD will be copied respectively.
  - Within one method, all boxes under UFLOOD, VFLOOD, UEBB and VEBB should cover the same area.
  - First all boxes specified for MANNING will be processed. Then all boxes for WHITE\_COLEBROOK and finally the boxes for CHEZY. Note that if boxes within different methods are overlapping, the values will be overwritten without a warning.

### 2.8.1.6 VISCOSITY (optional)

The horizontal eddy viscosity coefficient is given here in  $\text{m}^2\text{s}^{-1}$ .

Default = 10.0

#### VISCOSITY

EDDYVISCOSITYCOEFF = *[val]*

CROSSDERIV = *[string]*

FULL\_REYNOLDS

OLD\_BND\_TREATM

#### **Explanation:**

<u>EDDYVISCOSITYCOEFF</u> = <i>[val]</i>	D	Eddy viscosity coefficient. Default = 10.0
<u>CROSS_DERIV</u> = <i>[string]</i>	D	Option is no longer supported. If a value is given it must be 'off'.
<u>FULL_REYNOLDS</u>	D	FULL_REYNOLDS is a flag keyword. If this keyword is specified, then the full Reynolds model for viscosity is used. Default = no full_reynolds.
<u>OLD_BND_TREATM</u>	D	OLD_BND_TREATM is a flag keyword. If this keyword is specified, then the old boundary condition for viscosity, $u = 0$ , is used. If the keyword is not specified then $du/dn=0$ is used. Default = no old_bnd_treatm. <b>note:</b> This option is used if the viscosity is constant for the whole model. For space varying viscosity see the next section.



### 2.8.1.7 HOR\_VISCOSITY (optional)

The space varying horizontal eddy viscosity coefficient is given here in  $m^2s^{-1}$ .

HOR\_VISCOSITY

GLOBAL

LOCAL

#### GLOBAL (mandatory)

Global data can be specified in two ways: first by giving one value for the complete computational grid, second by giving values for each grid point. The order in which these values are to be given is specified by the layout flag.

GLOBAL

LAYOUT = *[ival]*

| CONST\_VALUES = *[val]*

<

| VARIABLE\_VALUES = <*[val]*>

FULL\_REYNOLDS = *[ival]*

#### Explanation:

<u>CONST_VALUES</u> = <i>[val]</i>	O	See paragraph 2.1.2.1 Default = 0
<u>VARIABLE_VALUES</u> = < <i>[val]</i> >	O	See paragraph 2.1.2.1
<u>LAYOUT</u> = <i>[ival]</i>	D	See paragraph 2.1.2.1 Default = 1
<u>FULL_REYNOLDS</u>	D	FULL_REYNOLDS is a flag keyword. If this keyword is specified, then the full Reynolds model for viscosity is used. Default = 0 (no full_reynolds).

#### LOCAL (optional)

See paragraph 2.1.2.2 for this subsection.

Note: This option HOR\_VISCOSITY is used when the viscosity is space varying. The viscosity should be specified in water level grid points.

### 2.8.1.8 BARRIERCOEFFICIENTS (optional)

Contraction or discharge coefficients for subcritical, supercritical and gate-restricting flow are given in this section. These coefficients depend on the flow direction only.

**BARRIERCOEFFICIENTS**

<B [*iseq*]:      CONTRSUBCRITICAL = [*val1*], [*val2*]  
                          CONTRSUPERCRITICAL [*val1*], [*val2*]  
                          RESTRICTING [*val1*], [*val2*] >

**Explanation:**

B[ <i>iseq</i> ]	S	Barrier sequence number as defined in MESH, boundaries, barriers.
CONTRSUBCRITICAL = [ <i>val1</i> ], [ <i>val2</i> ]	M	Contraction coefficients for subcritical flow. The values [ <i>val1</i> ] and [ <i>val2</i> ] will be employed in case of respectively high tide (i.e. in positive direction) and low tide (i.e. in negative direction). Meaningful only in WAQUA.
CONTRSUPERCRITICAL = [ <i>val1</i> ], [ <i>val2</i> ]	M	Contraction coefficients for supercritical flow. The values [ <i>val1</i> ] and [ <i>val2</i> ] will be employed in case of respectively high tide (i.e. in positive direction) and low tide (i.e. in negative direction). Meaningful only in WAQUA.
RESTRICTING = [ <i>val1</i> ], [ <i>val2</i> ]	M	Contraction coefficients for gate-restricting flow. The values [ <i>val1</i> ] and [ <i>val2</i> ] will be employed in case of respectively high tide (i.e. in positive direction) and low tide (i.e. in negative direction).

Notes: - The default value for the non-specified coefficient is 1.0.

- The contraction coefficients for gate-restricting flow can be used in both WAQUA and TRIWAQ models
- Apart from the flow direction, the contraction coefficient for gate-restricting (subcritical) flow may depend on the orifice height. If this is the case, the keyword DISCHARGECEFFICIENTS instead BARRIERCOEFFICIENTS should be completed (see par. 2.8.1.9).
- More information on barriers with flow conditions and their corresponding contraction coefficients can be found in § 3.5.1, Barriers and sluices, of the User's Guide WAQUA: general information.

**2.8.1.9 DISCHARGECEFFICIENTS (optional)**

Information concerning the discharge coefficients for gate-restricting subcritical flow is given in this section. The given discharge coefficients depend on the flow direction and the gate

opening. This section has two subsections.

#### DISCHARGECOEFFICIENTS

SCALE\_MODEL

COEFFICIENTS

First, the modelling of the effect of the barriers on the flow can be given in subsection SCALE\_MODEL. In subsection COEFFICIENTS the discharge coefficients for gate-restricting subcritical flow that depend on both the flow direction as well as the wet opening at the barrier can be given.

#### **SCALE\_MODEL (optional)**

In this subsection the effect of the barrier characteristics such as gate and sill on the flow is determined.

SCALE\_MODEL

| SMALL

<

| LARGE

#### **Explanation:**

SMALL	○	If specified, small-scale modelling will be employed.
LARGE	○	If specified, large-scale modelling will be employed. Default: small-scale modelling in case of TRI-WAQ and large-scale modelling in case of WAQUA.

Notes: - For WAQUA models, only large-scale modelling is possible.

- If the keyword SCALE\_MODEL is specified in the input, it must be followed by either SMALL or LARGE.
- More information on modelling the effect of the barrier characteristics on flow can be found in § 3.5.1, Barriers and sluices, of the User's Guide WAQUA: general information.

#### **COEFFICIENTS (optional)**

In this subsection the discharge coefficients for gate-restricting subcritical flow, which depend on the flow direction and the opening at the barrier, are given. Since, the actual gate heights and sill depths may be given as time series (see FLOW, FORCINGS, BARRIERS), a time frame

can be specified for which the given discharge coefficients have to be indicated.

**COEFFICIENTS**

```

<   T : B [iseq]
    | ORIFICE_HEIGHT = [val]
    <
    | FRAME = [val1][val2]
    DISCO = [val1], [val2]
>

```

**Explanation:**

*B*[iseq]                                   S           Barrier sequence number as defined in MESH, boundaries, barriers.

Note: A special case is B0, which means that the orifice heights or time frame and the discharge coefficients as given below are expanded into all barrier points. As a consequence, the specification of B1...Bn and that of B0 are mutually exclusive.

ORIFICE\_HEIGHT=[val]                   O           Orifice height, i.e. wet opening, at a barrier point with sequence number *[iseq]* for which the discharge coefficients are specified.

Note: The orifice heights must be specified in ascending order.

FRAME=[val1] [val2]                   O           *[val1]* is the first time for which the discharge coefficients are given. *[val2]* is the last time for which the same coefficients are given. These times are given in elapsed minutes from midnight of the simulation start date.

DISCO=[val1], [val2]                   M           Discharge coefficients for given orifice height or in given time frame at given barrier sequence number. The values *[val1]* and *[val2]* are the discharge coefficients as employed during respectively high tide (i.e. in positive direction) and low tide (i.e. in negative direction).

Notes: - For the cases beyond the time frame or orifice heights or if the keyword DISCHARGE\_COEFFICIENTS has not been specified, the values as given in BARRIER\_COEFFICIENTS, restricting will be employed.

- If the keyword `ORIFICE_HEIGHT` is used, the fully open and closed barriers can also be indicated as well. For example, `ORIFICE = -99.9` may represent a closed barrier and `ORIFICE = 99.9` a complete open barrier.
- When the actual gate height and sill depth as given in `FLOW`, `FORCINGS`, `BARRIERS` are such that the corresponding orifice height is in between two adjacent values as given here, the associated discharge coefficient for both inflow and outflow are determined from the corresponding values (specified by `DISCO`) by means of linear interpolation.
- Depending on the barrier configuration either the orifice heights or the time frame, for which the given discharge coefficients have to be specified, must be given. For example, if each barrier has the same opening, discharge coefficients may be specified for various orifice heights. When the orifice height of each barrier is different from the other one during a certain period, discharge coefficients may be given in the corresponding time frame.
- More information on the determination of discharge coefficients can be found in § 3.5.1, Barriers and sluices, of the User's Guide `WAQUA`: general information.

### 2.8.1.10 WEIRS (optional)

In this section some weir related coefficients are given.

#### WEIRS

THETAC [*val*]

GROYNES\_REDUCTION\_FACTOR = [*val*]

OTHERS\_REDUCTION\_FACTOR = [*val*]

AUTO\_SILL\_HEIGHT

VILLEMONTTE

#### **Explanation:**

`THETAC` = [*val*]

D Weighing factor for the loss of energyheight of a weir. It is used as follows:

$$\Delta E_{new} = (1 - \Theta_C) * \Delta E_{new} + \Theta_C * \Delta E_{old}$$

where:

$\Delta E_{new}$  : the computed energy loss of this weir on the current time step (m)

$\Delta E_{old}$  : The energy loss of this weir on the previous time step

$\Theta_C$  : Value of `THETAC` (-)

THETAC can vary between 0. and 1., where 0. means that previous values are not accounted for at all and 1. means that the energyloss of the weir does not change in the time. THETAC can be used in case a model shows instable behaviour. Because THETAC introduces a slackening into the model it can only be used in case of permanence.  
 Default = 0.6.

Note: At (nearly) perfect weirs (i.e. supercritical flow), the recommended value of is 0.6 (at least > 0.5, to prevent numerical oscillations during the simulation).

- |                                  |   |   |
|----------------------------------|---|---|
| GROYNES_REDUCTION_FACTOR = [val] | D | Reduction factor for weirs that are marked as groynes. The groynes reduction factor relates to the energy loss caused by the weir. It can vary between 0. and 1., where 0. means that the energy loss is completely reduced, which in fact means that the weir no longer has any influence, and 1. means there is no reduction of the energy loss at all.<br>Default = 1. |
| OTHERS_REDUCTION_FACTOR = [val]  | D | Reduction-factor for weirs that are not marked as groynes. For its values and the meaning of these values see GROYNES_REDUCTION_FACTOR above.<br>Default = 1.   |

Note: It is recommended to set the values of the reduction factors > 0.

**Explanation:**

- |                  |   |   |
|------------------|---|---|
| AUTO_SILL_HEIGHT | D | Flag keyword to specify whether the sill heights are recomputed automatically for all weirs. If this flag equals zero only the sill heights equal to -99.00 are updated.<br>Default = 0   |
| VILLEMONTE       | D | Flag keyword to specify whether the VILLEMONTE model should be used for weirs or the Wijbenga-model: see also §2.9, Weirs, of WAQUA/TRIWAQ two- and threedimensional shallow water flow model, Technical documentation (SIMONA report 99-01). |

Default = 0.

### 2.8.1.11 VELOCITY\_PROFILE

In this subsection the variables and flags related to the vertical velocity profile are defined. This information is meaningful only for TRIWAQ.

#### VELOCITY\_PROFILE

```

  ZZERO [val]
  | LOG_BOUNDARIES
  <
  | BOUXDIM

```

#### Explanation:

<u>ZZERO</u> =[ <i>val</i> ]	D	<p>Roughness height used in the formula for the vertical velocity log-profile. If the formula for friction is defined as FORMULA = 'Z0_based', Zzero will also be used for the computation of the 3D-Chezy friction coefficients (par. 2.8.1.5).</p> <p>Limitations: <math>Zzero &lt; 0.5 * (\text{depth criterion})</math>; the depth criterion is defined in the section FLOW, PROBLEM, DRYING (par. 2.8.1.4).</p> <p>Default: 0.0112.</p>
<u>LOG_BOUNDARIES</u>	D	<p>If this keyword is specified, the logarithmic vertical velocity profile will be used in the velocity boundary points.</p> <p>Default: uniform vertical velocity profile will be used in the open boundary points.</p>
<u>BOUXDIM</u>	D	<p>If this keyword is specified, the velocity profile is distributed in the vertical in nonuniform manner specified by the keyword LAYER in subsection TIMESERIES of FORCINGS (see Section 2.9.1.3).</p> <p>Default: No vertically distributed velocity profile will be specified.</p>

Note: If VELOCITY\_PROFILE block is not specified in the input **and** the parabolic vertical viscosity profile (see Section 2.14.2) is chosen, the Zzero coefficients will be derived from the 2D friction coefficients defined in section 2.8.1.5. The Z0\_based method is not allowed in such a case to prevent circular reference.

### 2.8.1.12 VERT\_CHEZY

In this subsection a choice can be made between two relations for the calculation of Chezy\_3D as a function of Chezy\_2DH.

```

VERT_CHEZY
  | COMPATIBLE
  <
  | VELOCITY
    
```

#### Explanation:

COMPATIBLE	X	If this keyword is specified, the old relation based on ratios of the layer-thickness is used.
VELOCITY	X	If this keyword is specified, the relation based on velocity-ratios is used. This one gives less differences in predicted waterlevels between 3D en 2 DH (both Waqua and one layer Tri-waq). This choice is mandatory for 3D models ( $k_{max} > 1$ ).



## 2.9 FORCINGS (optional)

### 2.9.1 Initial values, boundaries, barriers and waves

In this subsection initial values and boundary conditions are given. This subsection is divided in thirteen subsections

#### FORCINGS

INITIAL

BOUNDARIES

TIMESERIES

FOURIER

HARMONIC

QHTABLES

DISCHARGES

BAR\_TIMES

BARRIERS

BAR\_SERIES

BAR\_TABLES

OBSERVATIONS

WAVES

#### 2.9.1.1 INITIAL (mandatory)

In this subsection initial values are given. INITIAL has five subsections.

#### INITIAL

WATLEVEL

UVELOCITY

VVELOCITY

READ\_FROM

COMPUTE

#### **WATLEVEL (optional)**

In this subsection initial water levels in meters (m) at water level locations are given. Input for WATLEVEL has a layout according to data fields, described in paragraph 2.1.2.

#### WATLEVEL

GLOBAL

LOCAL

If WATLEVEL is not specified, the water levels across the entire grid will be initialized to zero.

**UVELOCITY (optional)**

In this subsection initial velocities in meters per second ( $ms^{-1}$ ) at u-velocity locations are given. Input for UVELOCITY has a layout according to data fields, described in paragraph 2.1.2.

UVELOCITY  
GLOBAL  
LOCAL

If UVELOCITY is not specified, the u-velocity component across the entire grid will be initialized to zero.

**VVELOCITY (optional)**

In this subsection initial velocities in meters per second ( $ms^{-1}$ ) at v-velocity locations are given. Input for VVELOCITY has a layout according to data fields, described in paragraph 2.1.2.

VVELOCITY  
GLOBAL  
LOCAL

If VVELOCITY is not specified, the v-velocity component across the entire grid will be initialized to zero.

**READ\_FROM (optional)**

In subsection READ\_FROM an SDS-file name, experiment name and time can be specified to read initial fields from an existing experiment on an SDS-file.

READ\_FROM  
EXP\_INITIAL = [text]      SDS\_INITIAL = [text]      TIME\_INITIAL = [val]  
REDEFINE\_LAYER\_THICKNESS

**Explanation:**

<u>EXP_INITIAL</u> = [text]	O	Experiment name.
<u>SDS_INITIAL</u> = [text]	M	SDS-file name. The given file name can contain an explicit path name. The use of any indication of a parent directory ('..') is allowed.

TIME_INITIAL=[ <i>val</i> ]	D	Time (in minutes) in the referred experiment (may differ from TSTART). Map data for this time level must exist on the referred SDS-file. If this keyword is omitted, then the default value TSTART of the new experiment is used; differences between the reference date of the referred and the new experiment are taken into account.
REDEFINE_LAYER_THICKNESS	D	Flag keyword that allows for redefinition of the layer thicknesses between the old and new experiment. If this flag is specified, the number of layers (KMAX) must be equal in both experiments and three-dimensional variables (e.g. velocities) are copied 1-to-1 from the old layers to the new layers. If this flag is specified here, one should also specify the flag in TRANSPORT/FORCINGS/INITIAL/READ_FROM.

- Notes:
- This option can be used to start a new simulation using data of a previous experiment. The only requirement is that the grid sizes (i.e. MMAX, NMAX and STEPSIZE) are the same. Only map-data are used for initialization, therefore the presence of restart data in the referred experiment is not required.
  - The simulation mode (WAQUA or TRIWAQ) may vary between the two experiments.
  - If the keyword REDEFINE\_LAYER\_THICKNESS is not specified, the number of layers may vary between the two experiments. However, only layers from the old experiment may be removed and/or layers may be added in the new experiment.
  - The initial condition for a simulation started using this option may differ slightly from the original simulation, as not all initial data are exactly the same as in that simulation. These discrepancies are caused by the fact that the Chezy-values are not updated after each computational step. To obtain initial condition that is exact the same as condition at the specified time-level in previous simulation option RESTART (see section RESTART) should be used.
  - If in the old experiment no horizontal or vertical turbulence model was selected, a turbulence model may be selected in the new experiment. In this case the turbulent energy and dissipation in the new experiment are initialized to  $10^{-7}$ .
  - If EXP\_INITIAL is not specified, the first experiment on the specified SDS file will be taken.

### COMPUTE (optional)

If this option is specified, the initial velocities will be derived from the water levels using the Chezy-formula for steady flow. This can shorten the running-in period of an experiment, yet

it is only meaningful in the case of quasi-steady flow condition (e.g. flow in a river). Therefore, the option COMPUTE is not available for spherical models.

COMPUTE  
VELOCITIES

**Explanation:**

VELOCITIES	D	Flag for computation of initial velocities. Default = 0 (no velocities, i.e. velocities will not be derived from the initial water levels)
------------	---	---

**2.9.1.2 BOUNDARIES (optional)**

In this subsection the type of the openings is specified.

BOUNDARIES  
 <B : OPEN [*iseq*]      BTYPE = [*text*]      BDEF = [*text*]      REFL = [*val*]  
           WGHTHALFTIME = [*val*]      SAME >  
DIS\_OPTIONS  
           ORIENTATION = [*text*]  
           DISTRIBUTE = [*text*]  
BOUND\_OPTIONS  
           | OLD\_REFL  
           <  
           | NEW\_REFL

**Explanation:**

OPEN [ <i>iseq</i> ]	M	Opening sequence number as defined in MESH.
BTYPE = [ <i>text</i> ]	M	Boundary type definition. Possible values: 'vel' for a velocity opening, 'wl' for a water level opening, 'disch' for a discharge opening, 'Riemann' for a Riemann-type (weakly-reflective) opening, 'disch-ad' for a discharge opening with automatic distribution, 'QH' for a QH-opening.

Limitations: - Horizontal and vertical orientation relative to the grid of the openings are allowed for all types of openings. Diagonals at 45° multiples are only allowed for water level openings.

- The tide openings must be positioned just outside the computational grid (see the computational grid description in § 3.2.1.1 of User's Guide WAQUA: general information).

The default computational grid, if none is explicitly given, extends from  $M=2$  through  $M=M_{MAX}-1$  and from  $N=2$  through  $N=N_{MAX}-1$ . In this case, a tide opening falls on one of the four lines  $M=1$ ,  $M=M_{MAX}$ ,  $N=1$  or  $N=N_{MAX}$ . In case of a velocity opening at  $N=N_{MAX}$  or  $M=M_{MAX}$ , boundary conditions take effect in grid-points at  $N=N_{MAX}-1$  or  $M=M_{MAX}-1$ .

In a grid-point only one type of opening is allowed. This means that a U- and V-velocity opening cannot begin or end at the same grid point.

All points of a discharge opening with automatic distribution must feed into the computational grid. This for instance means that for the default grid a horizontal 'disch-ad' opening may not start at  $M=1$  nor end at  $M=M_{MAX}$  but must start at  $M>1$  and end at  $M<M_{MAX}$ .

In general, the open boundaries feed into the computational grid from just outside. This also implies that the ends of an open boundary do not extend beyond the grid. For example, an opening on the  $N=1$  line would fall within the range  $M=2$  through  $M=M_{MAX}-1$ .

Open boundaries may be defined in any order regardless of their position on the grid.

$BDEF={text}$

M Form of the boundary definition. Possible values: 'series', 'fourier' or 'QH'. 'Fourier' can be specified as Fourier series in subsection FOURIER, or as harmonic constants in subsection HARMONIC. 'QH' must be specified as a QH-relation table in subsection QHTA-BLES.

Note: The order in which open boundaries must be specified is restricted: series type openings must be specified first, followed by fourier type openings, followed by QH type openings. However, within these opening types, the order may be at random.

Limitations: - Riemann boundary conditions can only be applied with  $BDEF = 'series'$ . Riemann invariants can only be applied if the water variations ( $\zeta$ ) are small compared to the local bottom level (depth  $d$ ). The reference plane for the depth should therefore be almost equal to Mean Sea Level. In other words: Riemann invariants type of boundary conditions should not be used in shallow water and "Wadden" areas (wetlands).

$REFL={val}$

D Coefficient for weakly-reflective open boundaries.  
 $REFL = 0$  results in a normal boundary condition (non-reflective)

WGHTHALFTIME= <i>[val]</i>	D	<p>Default = 0.0</p> <p>Coefficient for discharge openings with automatic distribution that determines the influence of weights of previous time-instances. WGHTH = 0.0 results in instantaneous adaptation of the discharge distribution to the current flow situation. Values &gt; 0 (e.g. 0.5 minute) retard the adaptations and may help to circumvent certain instabilities.</p>
SAME	D	<p>Default = 0.5 (min).</p> <p>SAME is a flag. If SAME is specified it is assumed that the conditions are the same at both ends of the opening. For a 'disch-ad' and a 'QH' opening the SAME flag must be specified!</p> <p>If not specified the assumption is: 'not the same'.</p>
DIS_OPTIONS	O	Section with options for discharges.
BOUND_OPTIONS	O	<p>Switch to specify if the new or old implementation of 'weakly reflective open boundary' should be used (see REFL).</p> <p><b>Note:</b> If this keyword is specified in the input, it must be followed by either OLD_REFL or NEW_REFL. This keyword can only be specified after the list of all boundaries and is used for each boundary.</p>
ORIENTATION	O	<p>ORIENTATION indicates the direction of positive discharges:</p> <p>POS_FORWARD = positive discharge corresponds to positive u/v-direction (default);</p> <p>POS_INWARD = positive discharge corresponds to into the domain.</p>
DISTRIBUTE	O	<p>DISTRIBUTE indicates the method for distributing discharges along a boundary:</p> <p>OPEN_ONLY = discharges are distributed over the wet cells along the boundary (default);</p> <p>SCREENS_TOO = discharges are distributed over the wet and dry cells along the boundary;</p> <p>ALL_DRY = if the boundary is completely dry, the discharges are distributed uniformly along the entire boundary, otherwise discharges are applied at wet cells only.</p>

### 2.9.1.3 TIMESERIES (optional)

When in subsection FLOW, FORCINGS, BOUNDARIES series openings are defined, the time series at points A and B must be given (if the SAME flag is given only one point must be specified). The time series are given at user defined points, which must be located at an end point of an opening. For more detailed information about time series refer to Section 2.1.3. If no values are given in TIMESERIES for a certain point and the SAME flag is not applicable, the boundary conditions for this point will be set to zero.

#### TIMESERIES

```

<   S : P [iseq]      TID = [val]      SERIES = [text]      LAYER = [ival]
    | FRAME = [val1] [val2] [val3]
    | VALUES = < [val] >                                     (i.c. series='regular')
    <
    | < TIME_AND_VALUE = [tval] [val] >
    |                                                         (i.c. series='regular')
>

```

#### Explanation:

P [iseq]	M	Point sequence number as defined in mesh
TID = [val]	M	Initial value at point [iseq]. The dimension depends on the chosen boundary type; $m$ or $ms^{-1}$ or $m^3s^{-1}$ .
SERIES = [text]	O	SERIES can have two possible values namely: 'regular' or 'irregular'. When SERIES = 'regular' keywords FRAME and VALUES are expected. When SERIES = 'irregular' keyword TIME_AND_VALUE is expected. When SERIES is not given, a constant value equal to the initial value is taken.
LAYER = [ival]	O	Index of the layer where the time series are given. Special case: LAYER = 0 means a uniform boundary condition in the vertical. This information is only meaningful when the keyword BOUxDIM has been given (see Section 2.8.1.10). Limitation: $0 \leq \text{LAYER} \leq \text{KMAX}$ . Default: 0 <b>Note:</b> The time series must be given for each layer.
FRAME = [val1] [val2] [val3]	O	[val1] is the first time at which a boundary condition is given. [val2] is the time interval at which a boundary condition is given. [val3] is the last time at which a boundary condition is given. (These times are given in (elapsed simulation) minutes)

- |                             |   |   |
|-----------------------------|---|---|
| VALUES= ([val1]... [val2])  | O | The values for open boundaries are given for the times as defined at the keyword frame. (dimension: See TID)  |
| TIME_AND_VALUE=[tval] [val] | O | In this case it is possible to give values for open boundaries at non-equidistant times. Time values must be specified in the format <i>day</i> hour:minute with respect to the simulation starting time. (dimension of values at times: See TID) |

### 2.9.1.4 FOURIER (optional)

The Fourier series are given at user defined points, which must be located at an endpoint of an opening. When in subsection FLOW, FORCINGS, BOUNDARIES Fourier openings are defined, the Fourier-series or the Harmonic constants at points A and B must be given. If the SAME flag is given (also in FLOW, FORCINGS, BOUNDARIES), only one point must be specified.

In the GENERAL part the angular frequencies for all (= N) fourier series are given. In the SERIES part the amplitude, phase etc. are given for each point. For each point a sequence of amplitudes and a sequence of phases must be given that exactly correspond (in number and sequentially) with the number of Fourier series.

#### FOURIER

##### GENERAL

OMEGA =<[val]>

##### SERIES

<S : P [iseq]      TID = [val]      AZERO = [val]  
AMPL =<[val]>  
PHASE =<[val]> >

#### **Explanation:**

- |                  |   |   |
|------------------|---|---|
| OMEGA= < [val] > | M | The angular frequencies are given here for N components in Fourier-related tide input ( $10^{-4}$ rad $s^{-1}$ ). |
| P[iseq]          | M | Point sequence number.  |
| TID=[val]        | M | Initial value at point [iseq] (m).  |
| AZERO=[val]      | M | Amplitude at point [iseq] for zero frequency (m).   |
| AMPL= < [val] >  | M | Sequence of amplitudes for N frequencies at point [iseq] (m).   |
| PHASE= < [val] > | M | Sequence of phases at point [iseq] for N frequencies. (rad)   |



### 2.9.1.5 HARMONIC (optional)

The Harmonic constants are given at user defined points, which must be located at an endpoint of an opening. When in subsection FLOW, FORCINGS, BOUNDARIES Fourier openings are defined, the Fourier-series or harmonic constants at points A and B must be given. If harmonic constants are specified (Fourier series at 1-1-1900) the Fourier series at TSTART will be computed. If the SAME flag is given (also in FLOW, FORCINGS, BOUNDARIES), only one point must be specified.

In the GENERAL part the names of the angular frequencies for all (= N) fourier series are given. In the CONSTANTS part the amplitude, phase etc. are given for each point valid at 1-1-1900. For each point a sequence of amplitudes and a sequence of phases must be given that exactly correspond (in number and sequentially) with the number of angular frequencies.

#### HARMONIC

##### GENERAL

OMEGA = <[val]>

TIMESHIFT = <[val]>

TIHARM = <[val]>

##### CONSTANTS

<S : P [iseq]      TID = [val]      AZERO = [val]

AMPL = <[val]>

PHASE = <[val]> >

#### Explanation:

<u>OMEGA</u> = < [val] >	M	The names of the angular frequencies are given here for N components in Fourier-related tide input. There are 195 commonly used names available, for instance 'M2', 'S2' and 'NU2 '. For a complete list of harmonic constants refer to the appendices.
<u>TIMESHIFT</u> = < [val] >	O	The timeshift in minutes in order to match the time-zone of the harmonic constants with the time-zone of WAQUA. When for instance the time-zone of the harmonic constants is GMT-wintertime and the time-zone of WAQUA is GMT-summertime the timeshift is +60 minutes.
<u>TIHARM</u> = <[val]>	O	Time interval to (re)compute the nodal factors (in minutes).

Note: The program will check whether the given time interval is a multiple of the time step of the simulation. If necessary, the time interval will be corrected to fulfil this condition. When TIHARM is set to zero (either explicitly or by the program), recalculations will *not* be performed.

P[ <i>iseq</i> ]	M	Point sequence number.
TID=[ <i>val</i> ]	M	Initial value at point [ <i>iseq</i> ] (m).
AZERO=[ <i>val</i> ]	M	Amplitude at point [ <i>iseq</i> ] for zero frequency (m).
AMPL= < [ <i>val</i> ] >	M	Sequence of amplitudes for N frequencies at point [ <i>iseq</i> ] (m).
PHASE= < [ <i>val</i> ] >	M	Sequence of phases at point [ <i>iseq</i> ] for N frequencies. (rad)

### 2.9.1.6 QHTABLES (optional)

When in subsection FLOW, FORCINGS, BOUNDARIES QH openings are defined, the QH-table for the openings must be given. A QH-table is given for the complete opening. It contains the relation between the total discharge (Q) through the opening and the corresponding water level (H). A QH-table must contain one QH-pair at least. Successive Q-values must be in ascending order.

```

QH



```

#### Explanation:

OPEN[ <i>iseq</i> ]	M	Opening sequence number as defined in mesh
TID=[ <i>val</i> ]	M	Initial value (wl) at opening [ <i>iseq</i> ]. The dimension: m.
QH=( [ <i>val1</i> ] [ <i>val2</i> ] )	M	[ <i>val1</i> ] represents the total discharge (Q) through the opening. [ <i>val2</i> ] represents the corresponding water level (H).

### 2.9.1.7 DISCHARGES (optional)

In this subsection Discharge sources can be defined. Discharge sources are defined by means of time series (for more detailed information refer to 2.1.3) for every discharge source point. Further the discharges for the outlet-points of powerstations must be specified here.

```

DISCHARGES
<   SOURCE : P [iseq]  SERIES = [text]  LAYER = [ival]  TYPE = [text]  POSITION = [ival]
    | FRAME = [val1][val2][val3]
    | VALUES = < [val] >                                     (i.c. series='regular')
<
    | <TIME_AND_VALUE = [tval][val] >
    |                                                         (i.c. series='regular')
>

```

**Explanation:**

P[ <i>iseq</i> ]	M	Point sequence number as defined in MESH, POINTS.
SERIES=[ <i>text</i> ]	M	SERIES can have two possible values namely: 'regular' or 'irregular'. When SERIES = 'regular' keywords FRAME and VALUES are expected. When SERIES = 'irregular' keyword TIME_AND_VALUE is expected.
LAYER=[ <i>ival</i> ]	D	Index of the layer where the discharge source is located. Special case: LAYER = 0 means that the discharge is equally distributed in the vertical. This information is only meaningful for TRIWAQ. Limitation: $0 \leq \text{LAYER} \leq \text{KMAX}$ . Default: 0
TYPE=[ <i>text</i> ]	O	For bubble screens give here: TYPE = 'bubble screen'.
POSITION=[ <i>ival</i> ]	O	Vertical position of bubble screen.
FRAME=[ <i>val1</i> ] [ <i>val2</i> ] [ <i>val3</i> ]	O	[ <i>val1</i> ] is the first time for which discharge rates are given. [ <i>val2</i> ] is the time interval at which discharge rates are given. [ <i>val3</i> ] is the last time at which discharge rates are given. (These times are given in (elapsed simulation) minutes)
VALUES= < [ <i>val</i> ] >	O	The values for discharge rates are given for the times as defined at the keyword frame ( $m^3s^{-1}$ ).
TIME_AND_VALUE=[ <i>tval</i> ] [ <i>val</i> ]	O	In this case it is possible to give discharge rates at non-equidistant times ( $m^3s^{-1}$ ).

- Limitations:
- Only one discharge source is allowed in a point P with the index *iseq*. Multiple definitions of sources in one point (m, n) are possible if they are specified separately using different point definitions (i.e. the points with different indices). In that case the contributions of the separate sources will be added during the computation.
  - Discharge sources are not allowed at dams or at computational grid enclosures.
  - In TRIWAQ, more than one discharge source is allowed in the same vertical (in point P *iseq*). If LAYER = 0 in a point P *iseq* is specified, no other sources are allowed in this vertical.
  - (Positive) Discharges must be specified for the outlet-points of all powerstations. The discharges for intake-points are identical to these values except from the sign which is reverted, and should not be specified by the user.

### 2.9.1.8 BAR\_TIMES (optional)

In this subsection the period for which barrier steering will be active is specified.

BAR\_TIMES

TFBARS = [val]      TIBARS = [val]      TLBARS = [val]

#### Explanation:

<u>TFBARS</u> = [val]	M	Time first (minutes) to adapt barrier dimensions during computation
<u>TIBARS</u> = [val]	M	Time interval (minutes) to adapt barrier dimensions during computation
<u>TLBARS</u> = [val]	M	Time last (minutes) to adapt barrier dimensions during computation.

The barrier dimensions are computed and adapted only at times equal to  $TFBARS + i \times TIBARS$ . At other times the barrier dimensions remain unchanged.

If the value of TIBARS exceeds that of a time step TSTEP than the barrier dimensions are changed in a special way. Indeed, in such a case the maximum change of a barrier dimension is computed as the specified barrier velocity (see Section 2.9.1.9) multiplied by TIBARS (if no barrier velocity is specified, it is assumed to be infinite).

Since the difference in the barrier dimensions can become large when TIBAR is relatively large w.r.t. TSTEP, it is advised to use a value of TIBARS close to TSTEP.

Notes: - When the keyword BAR\_TIMES is omitted, the following default values are used:

TFBARS: tstart (see flow/problem/timeframe)  
TIBARS: 0.5 \* tstep (see flow/problem/methodvariables)  
TLBARS: tstop (see flow/problem/timeframe)

- Barrier dimensions are computed and adapted at the beginning of (half) a time step.

### 2.9.1.9 BARRIERS (optional)

In this subsection the barrier characteristics are given.

Two different methods for specification of the barrier dimensions are available.

The older one is that time-series are specified for the sill depth, gate height and barrier width, directly under the current keyword. In this case the barrier characteristics are defined in TIMESERIES format (refer to 2.1.3).

The newer method is that time series and tables are defined separately under keywords BAR\_SERIES (section 2.9.1.10) and BAR\_TABLES (section 2.9.1.12). When this method

is used the timeseries and tables are referenced here using keywords GLOBAL and CONDITION.

For every barrier, as defined in MESH, the characteristics have to be given here!

More information on barriers can be found in § 3.5.1, Barriers and sluices, of the User's Guide WAQUA: General Information.

Subsections are

BARRIERS

SILL\_DEPTH

GATE\_HEIGHT

BARRIER\_WIDTH

GLOBAL

CONDITION

**Global layout:**

BARRIERS

B [*iseq*]:

SILL\_DEPTH :

INITIAL [*val*]

VELOCITY = [*val*]

RELATIVE MINIMAL = [*val*]

SERIES = [*text*]

| FRAME = [*val1*][*val2*][*val3*]

| VALUES = <[*val*]>

(i.c. series='regular')

<

| <TIME\_AND\_VALUE = [*tval*][*val*]>

(i.c. series='regular')

|

GATE\_HEIGHT

(TIMESERIES like under SILL\_DEPTH)

BARRIER\_WIDTH

(TIMESERIES like under SILL\_DEPTH)

GLOBAL

| FIXED\_STATE

<

| TB [*iseq*]

| | DISCHARGE

| | C [*iseq1*] | REMOTE [*text1*] (C [*iseq2*] | MINUS [*text2*] | OBS )

| | (LAYER [*ival*])

| | <

| | LEVEL

| | P [*iseq1*] | REMOTE [*text1*] (P [*iseq2*] | MINUS [*text2*] | OBS )

| | <

| | CONSTITUENT [*iseq1*]

```

| | P [iseq2]| REMOTE [text1] (P [iseq3] | MINUS [text2] | OBS )
| | (LAYER [ival])
| <
| | PRESSURE
| | P [iseq1]| REMOTE [text] OBS
<
| TS [iseq]
CONDITION
IF [Condition1] THEN [Action1]
ELSEIF [Condition2] THEN [Action2]
:
ELSE [Action]
END

```

### SILL\_DEPTH (mandatory)

The sill depths are given here. The sign of all sill depths depends on the keyword SILL\_DEPTH under main keyword DEPTH\_CONTROL (see section 2.4.1.1), which is either 'pos\_downwards' or 'pos\_upwards'.

#### Explanation:

INITIAL=[val]	M	Initial sill depth (m).
VELOCITY = [val]	D	Maximum velocity of the sill-level or gate or barrier_width (m / s). Default: maximum velocity is infinite.
RELATIVE	O	Flag indicates whether the given velocity is relative to the opening width, or absolute. Default: absolute velocity is given.
MINIMAL=[val]	O	Gives a minimal velocity for changing the sill-level or gate or barrier_width (m / s). The maximum change of a barrier dimension will be the maximum value of the relative velocity multiplied with the reference value and the minimal velocity.
SERIES=[text]	O	SERIES can have two possible values namely: 'regular' or 'irregular'. When SERIES = 'regular' keywords FRAME and VALUES are expected. When SERIES = 'irregular' keyword TIME_AND_VALUE is expected. When SERIES is not given, a constant value equal to the initial value is taken.

FRAME= <i>[val1]</i> <i>[val2]</i> <i>[val3]</i>	O	<i>[val1]</i> is the first time for which a sill depth is given. <i>[val2]</i> is the time interval at which sill depths are given. <i>[val3]</i> is the last time at which a sill depth is given. These times are given in (elapsed simulation) minutes.
VALUES= < <i>[val]</i> >	O	The values for sill depths are given for the times as defined at the keyword FRAME (m).
TIME_AND_VALUES= <i>[tval]</i> <i>[val]</i>	O	In this case it is possible to give sill depths (m) at non-equidistant times. Warning: keyword must be repeated on each line.

Note: The features of barriers have been described in Section 3.5.1 of this User's Guide WAQUA: General information.

## GATE\_HEIGHT (mandatory)

The gate heights are given here. Gate heights are positive upwards.

### Explanation:

INITIAL <i>[val]</i>	M	Initial gate height (m).
SERIES= <i>[text]</i>	O	See under SILL_DEPTH.
VELOCITY= <i>[val]</i>	D	See under SILL_DEPTH.
RELATIVE	O	See under SILL_DEPTH.
MINIMAL= <i>[val]</i>	O	See under SILL_DEPTH.
FRAME= <i>[val1]</i> <i>[val2]</i> <i>[val3]</i>	O	<i>[val1]</i> is the first time for which a gate height is given. <i>[val2]</i> is the time interval at which gate heights are given. <i>[val3]</i> is the last time at which a gate height is given. (These times are given in minutes.)
VALUES= < <i>[val]</i> >	O	The values for gate heights are given for the times as defined at the keyword FRAME (m).
TIME_AND_VALUES = < <i>[tval]</i> <i>[val]</i> >	O	In this case it is possible to give gate heights (m) at non-equidistant times.

Note: If a gate height is specified for TRIWAQ, then from the free surface to the position of the gate height the flow is set to zero. The program computes for which layers the flow is set to zero. This is similar to the approach for sill depths in TRIWAQ, in which the flow near the bottom is set to zero.

**BARRIER\_WIDTH (mandatory)**

The effective widths for barriers are given here. The effective width is the barrier width divided by the grid size STEPSIZE. BARRIER\_WIDTH is the fraction of the grid space that is open (BARRIER\_WIDTH = 0.0 means entirely closed to flow.)

**Explanation:**

INITIAL= <i>val</i>	M	Initial effective width (dimensionless).
SERIES= <i>text</i>	O	See under SILL_DEPTH.
VELOCITY= <i>val</i>	D	See under SILL_DEPTH.
RELATIVE	O	See under SILL_DEPTH.
MINIMAL= <i>val</i>	O	See under SILL_DEPTH.
FRAME= <i>val1</i> <i>val2</i> <i>val3</i>	O	<i>val1</i> is the first time for which an effective width is given. <i>val2</i> is the time interval at which effective widths are given. <i>val3</i> is the last time at which an effective width is given. (These times are given in (elapsed simulation) minutes.)
VALUES= < <i>val</i> >	O	The values for effective widths are given for the times as defined at the keyword FRAME (dimensionless).
TIME_AND_VALUES= [ <i>tval</i> ] [ <i>val</i> ] >	O	In this case it is possible to give effective widths (dimensionless) at non-equidistant times.

Limitations: - In TRIWAQ, BARRIER\_WIDTH is assumed to be 1.

**GLOBAL (optional)**

Here one can define the initial steering of a barrier by selecting a barrier table or barrier time series that is defined under keywords BAR\_SERIES (section 2.9.1.10) and BAR\_TABLES (section 2.9.1.12). In case of a barrier steering table a parameter definition must be specified.

When a condition is used for a barrier, the fixed state, the table or the time series specified here is used only at the start of the simulation, as long as no condition evaluates to true.

**Explanation:**

FIXED_STATE	X	If this keyword is specified, the barrier parameters will be fixed at their current values. So the barrier will not move at all.
TS [ <i>iseq</i> ]	X	Time series sequence number for the steering of the barrier



TB $[iseq]$	X	Table sequence number for the steering of the barrier. In case a table is defined, a parameter definition is expected. The parameter definition can be either of the next possibilities:
DISCHARGE C $[iseq]$   REMOTE['runid:crv'] (LAYER $[ival]$ )	O	Parameter for the table is the discharge over the cross section of curve number $[iseq]$ in own domain or remote curve with name $crv$ in domain with runid $runid$ . If the curve happens to be a point curve, it should be defined in USECTIONS or VSECTIONS (see § 2.8.3). LAYER has only meaning for TRIWAQ. In case the keyword LAYER is omitted the total discharge over the cross section is used, otherwise the discharge in layer $[ival]$ is used.
DISCHARGE C $[iseq]$   REMOTE['runid:crv'] OBS (LAYER $[ival]$ )	O	Parameter for the table is the difference between predicted and observed discharges over the cross section of curve number $[iseq]$ in own domain or remote curve with name $crv$ in domain with runid $runid$ .
DISCHARGE C $[iseq1]$   REMOTE['runid1:crv1'] C $[iseq2]$   MINUS['runid2:crv2'] (LAYER $[ival]$ )	O	Parameter for the table is the difference between predicted discharges over the cross sections of the two specified curves. Either of the two curves can be located in the own domain or in a remote domain, i.e. the following four combinations are possible: C $[iseq1]$ C $[iseq2]$ REMOTE['runid1:crv1'] C $[iseq2]$ C $[iseq1]$ MINUS['runid2:crv2'] REMOTE['runid1:crv1'] MINUS['runid2:crv2']
LEVEL P $[iseq]$   REMOTE['runid:pnt']	O	Parameter for the table is the water level in point number $[iseq]$ in own domain or remote point with name $pnt$ in domain with runid $runid$ .
LEVEL P $[iseq]$   REMOTE['runid:pnt'] OBS	O	Parameter for the table is the difference between predicted and observed water levels in point number $[iseq]$ in own domain or remote point with name $pnt$ in domain with runid $runid$ .
LEVEL P $[iseq1]$   REMOTE['runid1:pnt1'] P $[iseq2]$   MINUS['runid2:pnt2']	O	Parameter for the table is the difference between predicted water levels in the specified points. Either of the two points can be located in the own domain or in a remote domain, i.e. the following four combinations are possible:

CONSTITUENT $[iseq1]$ $P[iseq2]$   REMOTE['runid:pnt'] (LAYER[ival])	O	$P[iseq1]$ $P[iseq2]$ REMOTE['runid1:pnt1'] $P[iseq2]$ $P[iseq1]$ MINUS['runid2:pnt2'] REMOTE['runid1:pnt1'] MINUS['runid2:pnt2'] Parameter for the table is the concentration of constituent number $[iseq1]$ in point number $[iseq2]$ in own domain or remote point with name $pnt$ in domain with runid $runid$ . LAYER has only meaning for TRIWAQ. In case the keyword LAYER is omitted the average concentration in all layers is used, otherwise the concentration in layer $[ival]$ is used.
CONSTITUENT $[iseq1]$ $P[iseq2]$   REMOTE['runid:pnt'] (LAYER[ival])	O OBS	Parameter for the table is the difference between predicted and observed concentrations of constituent number $[iseq1]$ in point number $[iseq2]$ in own domain or remote point with name $pnt$ in domain with runid $runid$ .
CONSTITUENT $[iseq1]$ $P[iseq2]$   REMOTE['runid1:pnt1'] $P[iseq3]$   MINUS['runid2:pnt2'] (LAYER[ival])	O	Parameter for the table is the difference between predicted concentrations of constituent number $[iseq1]$ in the specified points. Either of the two points can be located in the own domain or in a remote domain, i.e. the following four combinations are possible: $P[iseq2]$ $P[iseq3]$ REMOTE['runid1:pnt1'] $P[iseq3]$ $P[iseq2]$ MINUS['runid2:pnt2'] REMOTE['runid1:pnt1'] MINUS['runid2:pnt2']
PRESSURE $P[iseq]$   REMOTE['runid:pnt']	OBS O	Parameter for the table is the difference between predicted and observed pressures in point number $[iseq]$ in own domain or remote point with name $pnt$ in domain with runid $runid$ . In case of WAQUA the pressure is computed by: $P(x) = \rho(x)g (\zeta(x) + d(x_{[iseq]}))$ In case of TRIWAQ the pressure is the average water pressure in the water column: $P(x) = \frac{1}{\zeta(x)+d(x)}g \int_{-d}^{\zeta} \left[ \int_z^{\zeta} \rho(x, z') dz' \right] dz$

### CONDITION (optional)

Using this part of the input it is possible to change the steering (table or time series) of the barrier depending on certain conditions.

**Explanation:**

```

IF [Condition1] THEN [Action1]
ELSEIF [Condition2] THEN [Action2]
:
ELSE [ActionN]
ENDIF

```

- In this part of the input it is possible to change the steering of the barrier depending on certain conditions.

Figure 2.2 shows the syntax of the if-statement. The figure shows that the ELSEIF part of the statement can be repeated, while the ELSE part is optional.

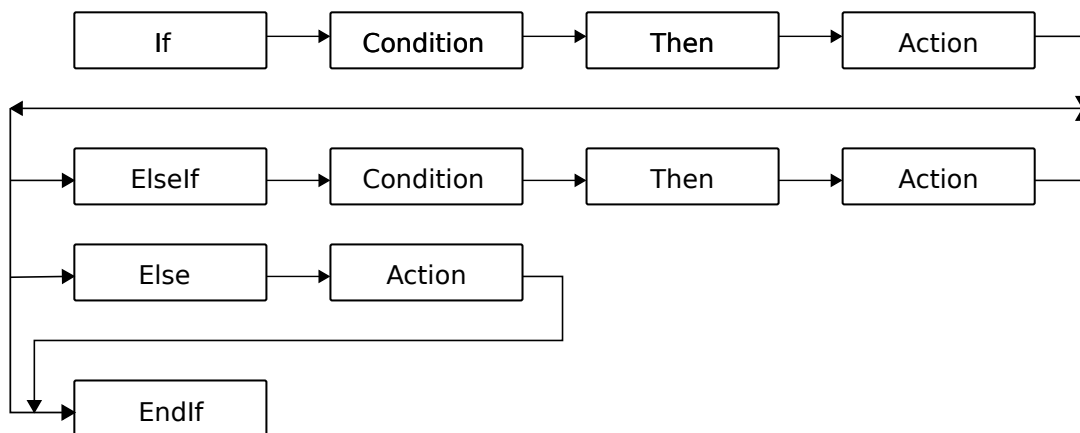

Figure 2.2: Syntax if-statement

At each time-instance at which the barrier steering is evaluated (see keyword `BAR_TIMES` in section 2.9.1.8) the program checks the conditions after the `IF` and `ELSEIF` keywords. As soon as one condition is met, the action, defined after the `THEN` keyword, is executed. If no conditions are true in the `IF-THEN-ELSEIF...` part, the action after the `ELSE` keyword is executed. If the `ELSE` keyword is not given no further action is taken.

- Notes:
- The reference time for a time series (`TIME=0.0`) is the moment of activation during the simulation. This approach differs from most of the other time series in `WAQUA`, because for these time series the reference time is midnight of the date given in `PROBLEM - TIMEFRAME`.
  - In case the action, which is to be executed, does not change the steering parameters no action is taken. For tables this is not important, but for time series it will have effect. The time for the time series will not be set to zero each time when the same condition is true.
  - In case the action, which is to be executed, is the same action that is already active no action is taken. So if `TS 1` is active and the new conditions should activate `TS 1`, no action is taken.

IF, THEN, ELSEIF, ELSE and ENDIF are keywords. Conditions and Actions are composed items.

Figure 2.3 shows the syntax of the composed item Condition. In a condition the keywords AND and OR can be used to compose complex conditions. The keywords AND and OR combine the 'Simple conditions into a combined condition. The evaluation (precedence) is from left to right.

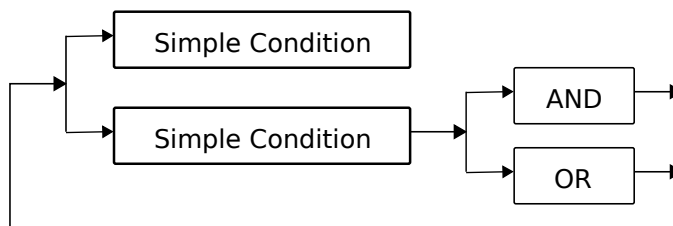

Figure 2.3: Syntax Condition

Figure 2.4 shows the syntax of a 'Simple condition'. The possible computed entities that can be used are:

- Current wind speed (WIND\_SPEED) or wind direction (WIND\_DIRECTION).
- Predicted discharge over a curve in own or remote domain:  
DISCHARGE C[iseq] or  
DISCHARGE REMOTE ['runid:curve name'].  
If the curve happens to be a point curve, it should be defined in USECTIONS or VSECTIONS (see § 2.8.3).
- Difference between predicted discharges over two curves in own or remote domain:  
DISCHARGE C[iseq1] C[iseq2] or  
DISCHARGE REMOTE ['runid:curve name'] C[iseq] or  
DISCHARGE C[iseq] MINUS ['runid:curve name'] or  
DISCHARGE REMOTE ['runid 1:curve name 1'] MINUS ['runid 2:curve name 2']
- Difference between predicted and observed discharges over a curve in own or remote domain:  
DISCHARGE C[iseq] OBS or  
DISCHARGE REMOTE ['runid:curve name'] OBS
- Predicted water level in a point in own or remote domain:  
LEVEL P[iseq] or  
LEVEL REMOTE ['runid:point name'].
- Difference between predicted water levels in two points in own or remote domain:  
LEVEL P[iseq1] P[iseq2] or  
LEVEL REMOTE ['runid:point name'] P[iseq] or  
LEVEL P[iseq] MINUS ['runid:point name'] or  
LEVEL REMOTE ['runid 1:point name 1'] MINUS ['runid 2:point name 2']

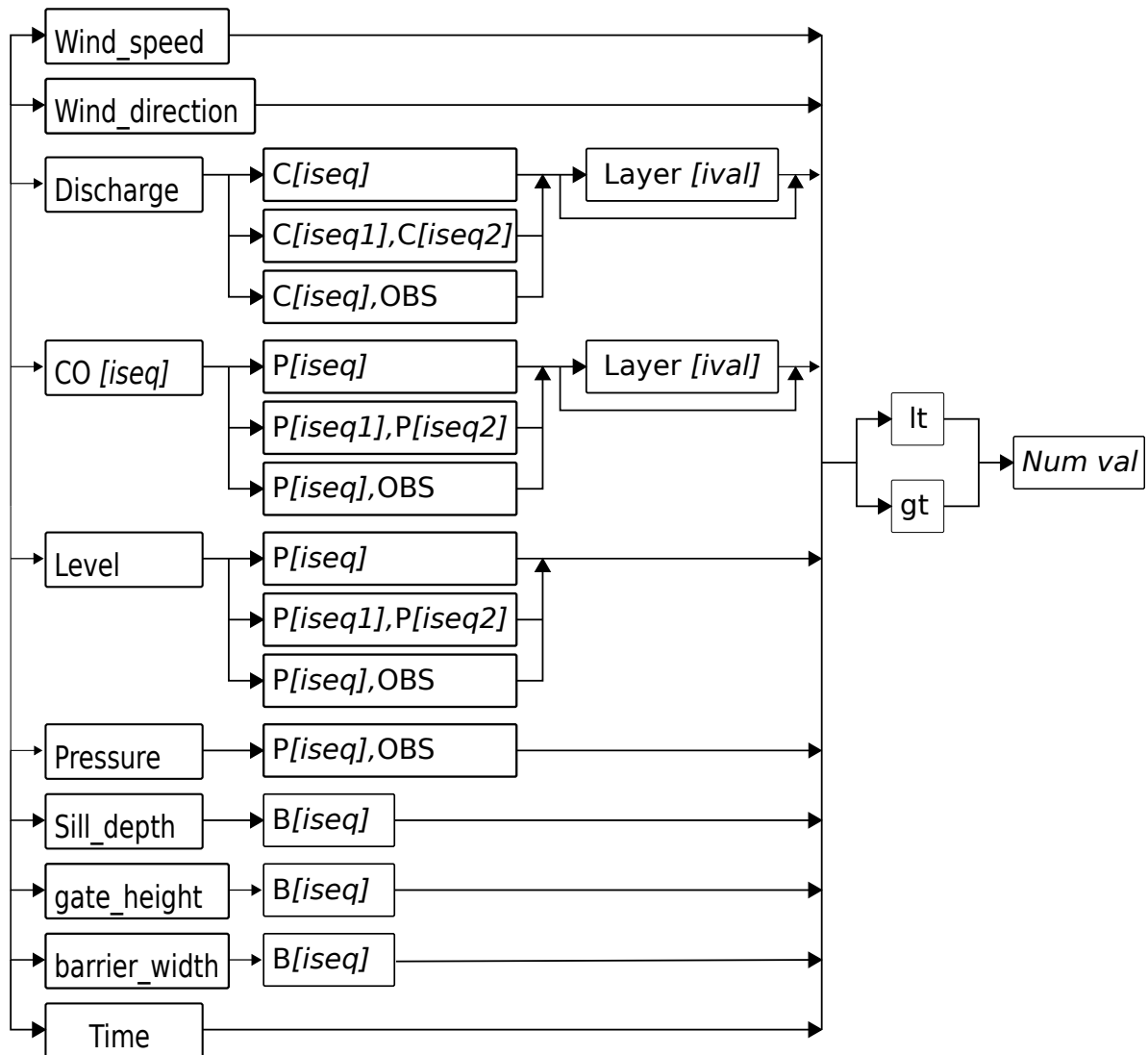

Figure 2.4: Syntax of Simple Condition

- Difference between predicted and observed water levels in a point in own or remote domain:  
 LEVEL P [*iseq*] OBS or  
 LEVEL REMOTE [*'runid:point name'*] OBS
- Predicted concentration of a constituent in a point in own or remote domain:  
 CO [*iseq1*] P [*iseq2*] or  
 CO [*iseq*] REMOTE [*'runid:point name'*].
- Difference between predicted concentrations of a constituent in two points in own or remote domain:  
 CO [*iseq1*] P [*iseq2*] P [*iseq3*] or  
 CO [*iseq1*] REMOTE [*'runid:point name'*] P [*iseq2*] or  
 CO [*iseq1*] P [*iseq2*] MINUS [*'runid:point name'*] or  
 CO [*iseq*] REMOTE [*'runid 1:point name 1'*] MINUS [*'runid 2:point name 2'*]
- Difference between predicted and observed concentrations of a constituent in a point in own or remote domain:  
 CO [*iseq1*] P [*iseq2*] OBS or  
 CO [*iseq*] REMOTE [*'runid:point name'*] OBS
- Difference between predicted and observed pressures in a point in own or remote domain:  
 PRESSURE P [*iseq*] OBS or  
 PRESSURE REMOTE [*'runid:point name'*] OBS
- Actual sill depth (SILL\_DEPTH B [*iseq*]), gate height (GATE\_HEIGHT B [*iseq*]) or relative barrier width (BARRIER\_WIDTH B [*iseq*]) of a barrier.
- Time condition (TIME) under which time series TS [*iseq*] or table TB [*iseq*] is activated.

Figure 2.5 shows the syntax of an 'Action'. An action consists of:

- a reference to a Timeseries (using its sequence number) as defined in FORCINGS / FLOW / BAR\_SERIES
- a reference to a table (using its sequence number) as defined in FORCINGS / FLOW / BAR\_TABLES.
- the keyword FIXED\_STATE. This action will fix the current barrier parameters so that the barrier will not move anymore.

When a table is used, the user has to define a parameter that will be used in the table. The syntax of parameter definitions is the same as in the definition of conditions. However, a few quantities that can be used in conditions are not available for addressing a table, i.e. WIND\_SPEED, WIND\_DIRECTION, SILL\_DEPTH, GATE\_HEIGHT, BARRIER\_WIDTH, and TIME. For the use of tables in computing the barrier dimensions refer to section 2.9.1.12 (BAR\_TABLES).

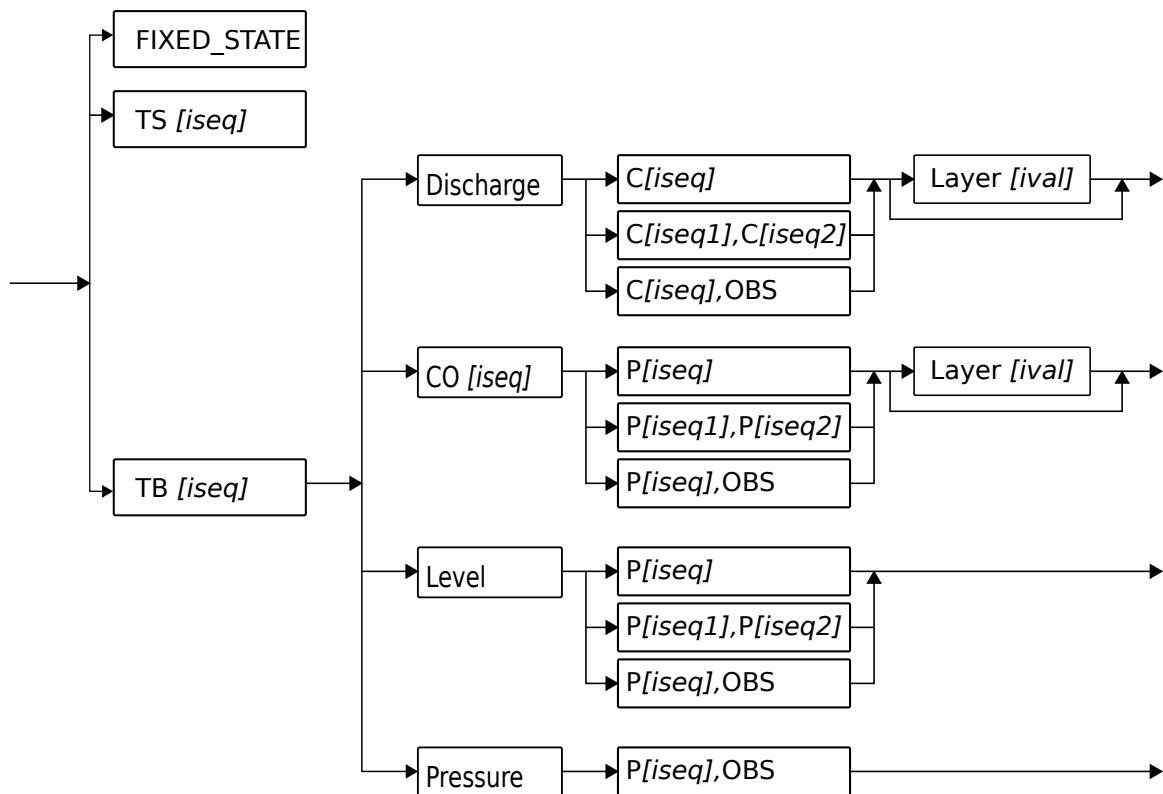

Figure 2.5: Syntax of Action

### 2.9.1.10 BAR\_SERIES (optional)

In this subsection barrier time series can be defined.

BAR\_SERIES

```
<   TS [iseq]:
      SILL ,      GATE ,      WIDTH ,
      SERIES = [text]
      | FRAME = [val1] [val2] [val3]
      | VALUES = < [val] >
    <
      | < TIME_AND_VALUES [tval] [val] ([val2] ([val3])) >
    >
```

#### Explanation:

TS[iseq]	S	Table sequence number
SILL	O	Flag indicating whether the sill level is given in the time series
GATE	O	Flag indicating whether the gate level is given in the time series
WIDTH	O	Flag indicating whether the barrier width is given in the time series

VALUES/TIME\_AND\_VALUES

- O Depending of the above flags the preferred <sup>2</sup> barrier dimensions are given for the specified times. Time values must be specified in the format *day hour:minute* and are relative to the time of activation of the time series. The order in which the barrier dimensions are to be specified is: sill level, gate level, barrier width. E.g. if in the input GATE and WIDTH are specified, two values are expected for each specified time, the first value defines the gate level, the second value defines the barrier width.
- For WAQUA models the sign of the sill depth depends on the keyword SILL\_DEPTH under main keyword DEPTH\_CONTROL, which is either 'pos\_downwards' or 'pos\_upwards'. For TRIWAQ models keyword DEPTH\_CONTROL / SILL\_DEPTH has no meaning.

### 2.9.1.11 OBSERVATIONS (optional)

In this subsection observations can be defined. Subsections are:

OBSERVATIONS

WATERLEVELS

PRESSURES

DISCHARGES

CONCENTRATIONS

### Global Layout

OBSERVATIONS

WATERLEVELS

```
<      STATION  NAME = [text]
      M = [ival]  N = [ival]
      SERIES = [text]
      | FRAME = [val1] [val2] [val3]
      | VALUES = < [val] >
<
      | < TIME_AND_VALUES = [tval] [val] >
```

---

<sup>2</sup>The preferred barrier dimension can be different from the actual barrier dimension because of the limitation defined by the maximum velocity in the 'global' section of the barrier definition



```

>
  PRESSURES
<
  STATION   NAME = [text]
    M = [ival]    N = [ival]
    SERIES = [text]
    | FRAME = [val1] [val2] [val3]
    | VALUES = < [val] >
  <
    | <TIME_AND_VALUES = [tval] [val] >
>
  DISCHARGES
<
  STATION   NAME = [text]
    | MNN = [ival1], [ival2], [ival3]
  <
    | MMN = [ival1], [ival2], [ival3]
    | LAYER = [ival]
    | SERIES = [text]
    | FRAME = [val1] [val2] [val3]
    | VALUES = < [val] >
  <
    | <TIME_AND_VALUES = [tval] [val] >
>
  CONCENTRATIONS
<
  STATION   NAME = [text]
    CONSTITUENT = [ival]
    M = [ival]    N = [ival]
    LAYER = [ival]
    SERIES = [text]
    | FRAME = [val1] [val2] [val3]
    | VALUES = < [val] >
  <
    | <TIME_AND_VALUES = [tval] [val] >
>

```

### WATERLEVELS (optional)

Water level observations are given here.

#### Explanation:

M	M	M-coordinate of the water level station
N	M	N-coordinate of the water level station
NAME	M	Name of the water level station

SERIES= <i>[text]</i>	M	SERIES can have two possible values namely: 'regular' or 'irregular'. When SERIES = 'regular' keywords FRAME and VALUES are expected. When SERIES = 'irregular' keyword TIME_AND_VALUE is expected. When SERIES is not given, a constant value equal to the initial value is taken.
FRAME= <i>[val1]</i> <i>[val2]</i> <i>[val3]</i>	O	<i>[val1]</i> is the first time for which a measurement is given. <i>[val2]</i> is the time interval at which measurements are given. <i>[val3]</i> is the last time at which a measurement is given. These times are given in (elapsed simulation) minutes.
VALUES= < <i>[val]</i> >	O	The values for measurements are given for the times as defined at the keyword FRAME (m).
VALUES/TIME_AND_VALUES	O	In this case it is possible to give measurement data at non-equidistant times.

## PRESSURES (optional)

Pressure observations are given here.

### Explanation:

M	M	M-coordinate of the observation station
N	M	N-coordinate of the observation station
NAME	M	Name of the observation station
SERIES= <i>[text]</i>	M	SERIES can have two possible values namely: 'regular' or 'irregular'. When SERIES = 'regular' keywords FRAME and VALUES are expected. When SERIES = 'irregular' keyword TIME_AND_VALUE is expected. When SERIES is not given, a constant value equal to the initial value is taken.
FRAME= <i>[val1]</i> <i>[val2]</i> <i>[val3]</i>	O	<i>[val1]</i> is the first time for which a measurement is given. <i>[val2]</i> is the time interval at which measurements are given. <i>[val3]</i> is the last time at which a measurement is given. These times are given in (elapsed simulation) minutes.
VALUES= < <i>[val]</i> >	O	The values for measurements are given for the times as defined at the keyword FRAME (m).

VALUES/TIME\_AND\_VALUES O In this case it is possible to give measurement data at non-equidistant times.

## CONCENTRATIONS (optional)

Concentration observations are given here.

### Explanation:

M	M	M-coordinate of the observation station
N	M	N-coordinate of the observation station
LAYER	O	K-coordinate of the observation station. In case LAYER is omitted, the depth averaged concentration is taken.
NAME	M	Name of the observation station
SERIES= <i>[text]</i>	M	SERIES can have two possible values namely: 'regular' or 'irregular'. When SERIES = 'regular' keywords FRAME and VALUES are expected. When SERIES = 'irregular' keyword TIME_AND_VALUE is expected. When SERIES is not given, a constant value equal to the initial value is taken.
FRAME= <i>[val1]</i> <i>[val2]</i> <i>[val3]</i>	O	<i>[val1]</i> is the first time for which a measurement is given. <i>[val2]</i> is the time interval at which measurements are given. <i>[val3]</i> is the last time at which a measurement is given. These times are given in (elapsed simulation) minutes.
VALUES= < <i>[val]</i> >	O	The values for measurements are given for the times as defined at the keyword FRAME (m).
VALUES/TIME_AND_VALUES	O	In this case it is possible to give measurement data at non-equidistant times.

## DISCHARGES (optional)

Discharge observations are given here.

### Explanation:

MNN	O	MNN-coordinates of the discharge-section may be given here, if it is a U-section.
MMN	O	MMN-coordinates of the discharge-section may be given here, if it is a V-section.

LAYER	O	K-coordinate of the observation station. In case LAYER is omitted, the depth integrated discharge is taken.
NAME	M	Name of the observation station
SERIES= <i>[text]</i>	M	SERIES can have two possible values namely: 'regular' or 'irregular'. When SERIES = 'regular' keywords FRAME and VALUES are expected. When SERIES = 'irregular' keyword TIME_AND_VALUE is expected. When SERIES is not given, a constant value equal to the initial value is taken.
FRAME= <i>[val1] [val2] [val3]</i>	O	<i>[val1]</i> is the first time for which a measurement is given. <i>[val2]</i> is the time interval at which measurements are given. <i>[val3]</i> is the last time at which a measurement is given. These times are given in (elapsed simulation) minutes.
VALUES= < <i>[val]</i> >	O	The values for measurements are given for the times as defined at the keyword FRAME (m).
VALUES/TIME_AND_VALUES	O	In this case it is possible to give measurement data at non-equidistant times.

### 2.9.1.12 BAR\_TABLES (optional)

In this subsection barrier steering tables can be defined.

#### BAR\_TABLES

```
<   TB [iseq]:
      VALUES = ([rval11], [rval12], [rval13], [rval14] )
                ([rval21], [rval22], [rval23], [rval24] )
                :
                ([rvaln1], [rvaln2], [rvaln3], [rvaln4] )
>
```

#### **Explanation:**

TB <i>[iseq]</i>	S	Table sequence number
VALUES=		
( <i>[rval11]</i> , <i>[rval12]</i> , <i>[rval13]</i> , <i>[rval14]</i> )		
( <i>[rval21]</i> , <i>[rval22]</i> , <i>[rval23]</i> , <i>[rval24]</i> )		
:		
:		

*([rvaln1], [rvaln2], [rvaln3], [rvaln4])*

M

Definition of barrier table. A table consists of several rows each containing the sill level, gate level, barrier width and a parameter value respectively. The parameter type is defined at the 'global' part of the barrier definition or in the action of a condition.

The parameter values must be given in ascending order.

The barrier dimensions during the computation will be adapted depending of the parameter value. In the table the two consecutive rows for the parameter is searched, such that the actual parameter value lies inside the interval that is described by the parameter values in the table. The preferred barrier dimensions are determined by linear interpolation between the values in the rows.

In case the actual parameter value is smaller than the lowest parameter value in the table, the barrier dimensions are set to the values in the first row of the barrier table.

In case the actual parameter value is larger than the highest parameter value in the table, the barrier dimensions are set to the values in the last row of the barrier table.

### 2.9.1.13 WAVES (optional)

In this subsection the coupling to a wave model can be defined.

Subsections are:

WAVES

FORCE

HEIGHT

PERIOD

DIRECTION

If one of these four subsections is specified then the other subsections must be specified as well. In this case an off-line coupling to a wave model is assumed and the four subsections contain values for the wave-induced force, wave height, wave period and wave direction (see explanation below). If none of the four subsections is given then an on-line coupling to a wave model is established. In this case the wave variables are delivered by the wave model in an OpenMI setting.

## **FORCE (optional)**

The wave-induced force in waterlevel points is given here (in  $N/m^2$ ).

### FORCE

#### UDIREC

GLOBAL (see paragraph 2.1.2.1)

LOCAL (see paragraph 2.1.2.2)

#### VDIREC

GLOBAL (see paragraph 2.1.2.1)

LOCAL (see paragraph 2.1.2.2)

## **Explanation:**

UDIREC	M	The x-component of the wave-induced force in waterlevel points.
VDIREC	M	The y-component of the wave-induced force in waterlevel points.

## **HEIGHT (optional)**

The significant wave height in waterlevel points is given here (in  $m$ ).

### HEIGHT

GLOBAL (see paragraph 2.1.2.1)

LOCAL (see paragraph 2.1.2.2)

## **PERIOD (optional)**

The mean absolute wave period in waterlevel points is given here (in  $s$ ).

### PERIOD

GLOBAL (see paragraph 2.1.2.1)

LOCAL (see paragraph 2.1.2.2)

## **DIRECTION (optional)**

The mean wave direction in waterlevel points is given here.

DIRECTIONUDIRECGLOBAL (see paragraph 2.1.2.1)LOCAL (see paragraph 2.1.2.2)VDIRECGLOBAL (see paragraph 2.1.2.1)LOCAL (see paragraph 2.1.2.2)**Explanation:**

UDIREC	M	The x-component of the wave direction in waterlevel points.
VDIREC	M	The y-component of the wave direction in waterlevel points.

**2.9.2 CHECKPOINTS (optional)**

In this subsection history output can be defined.

CHECKPOINTSLEVELSTATIONSP [*iseq1*] ... P [*iseqN*]CURRENTSTATIONSP [*iseq1*] ... P [*iseqN*]UCTIONSC [*iseq1*] ... C [*iseqN*]VCTIONSC [*iseq1*] ... C [*iseqN*]WEIRSMNMXBOX = (*ival*, [*ival*]; [*ival*], [*ival*])**Explanation:**

LEVELSTATIONS <u>P</u> [ <i>iseq1</i> ] ... <u>P</u> [ <i>iseqN</i> ]	O	Water level stations are selected grid points, defined in MESH (subsection POINTS), at which computed water levels are printed and is written to SDS-file for drawing time histories.
CURRENTSTATIONS <u>P</u> [ <i>iseq1</i> ] ... <u>P</u> [ <i>iseqN</i> ]	O	Current stations are selected water level grid points, defined in MESH, at which current magnitude is calculated and printed and is written to SDS-file for drawing time histories.

UCTIONS  $c[i_{seq1}]... c[i_{seqn}]$

- O U-transport cross sections are selected segments of grid columns (defined in MESH, CURVES) at which mass transport and advective, diffusive and total constituent transport are printed (TRANSPORT-part of simulation), and all but the last of these are written on the SDS-file for drawing time histories. All curves must be vertical (Mstart=M end).

VCTIONS  $c[i_{seq1}]... c[i_{seqn}]$

- O V-transport cross sections are selected segments of grid rows (defined in MESH, CURVES) at which mass transport and advective, diffusive and total constituent transport are printed (TRANSPORT-part of simulation), and all but the last of these are written on the SDS-file for drawing time histories. All curves must be horizontal (Nstart=N end).

WEIRS MNMNBOX = ( $[ival], [ival]; [ival], [ival]$ )

- O Weirs located in boxes specified by MNMNBOX are selected for time-history output (local flow-conditions, discharge, energy loss). A box is defined by specifying its opposite corner points ( $m1,n1;m2,n2$ ), where  $m1 \leq m2$  and  $n1 \leq n2$ . It is possible to define more than one MNMNBOX for time history-output for weirs.



## 2.10 HYDRODYNAMIC (optional)

In this section numerical parameters for non-hydrostatic computations can be specified.

### HYDRODYNAMIC

THETA = [val]  
MAXITER = [ival]  
RELACCURINIT = [val]  
RELACCURRHS = [val]  
RELAXATION = [val]  
PREC\_FREQUEN = [ival]  
BOX\_SCHEME  
IGNORECREEP  
TSTART = [val]

### **Explanation:**

<u>THETA</u> =[val]	D	Coefficient for time integration. Default = 1.0.
<u>MAXITER</u> =[ival]	D	Maximum number of iterations for solving the pressure correction equation. Default = 40.
<u>RELACCURINIT</u> = [val]	D	Relative accuracy with respect to the initial residual. Default = 0.0.
<u>RELACCURRHS</u> =[val]	D	Relative accuracy with respect to the right-hand side. Default = 0.01.
<u>RELAXATION</u> =[val]	O	Relaxation parameter for iterative solver.
<u>PREC_FREQUEN</u> =[ival]	D	Number of times the preconditioner is updated. Default = 10.
<u>BOX_SCHEME</u>	D	This is a flag keyword that specifies whether the box scheme must be used in the discretisation of the gradient matrix. Default = no box scheme.
<u>IGNORECREEP</u>	D	This is a flag keyword that specifies whether creep must be ignored in the discretisation of the gradient matrix. Default = no ignorecreep.
<u>TSTART</u> =[val]	D	Start time for non-hydrostatic computations. Default = 0.0.

## 2.11 TRANSPORT (optional)

In this section the transport part of the model can be defined. TRANSPORT is optional. This section is divided in three subsections.

### TRANSPORT

PROBLEM

FORCINGS

CHECKPOINTS

### 2.11.1 PROBLEM (mandatory)

In this subsection the problem definition of the transport model is given. PROBLEM has six subsections

#### PROBLEM

CONSTITUENTS

SALINITY

TEMPERATURE

METHODVARIABLES

FALL\_VELOCITIES

TURBULENCE\_TRANS

#### 2.11.1.1 CONSTITUENTS (optional)

In this subsection the constituents used in the transport model are defined.

#### CONSTITUENTS

<CO [*iseq*]: POLUTANT = [*text*]      PUNIT = [*text*] >

#### **Explanation:**

<u>CO</u> [ <i>iseq</i> ]	S	Sequence number of constituent.
<u>POLUTANT</u> = [ <i>text</i> ]	M	Name of the constituent. This name will appear in the legend of constituent maps and in the legend of relevant time histories.
<u>PUNIT</u> = [ <i>text</i> ]	M	Name of the unit of concentration for this particular constituent. This name will appear in the legend of constituent maps and in the legend of relevant time histories. The unit name is free and is of no influence on the computation in WAQUA.

Limitation: The maximum length of *[text]* is 20 characters.

### 2.11.1.2 SALINITY (optional)

The constituent number used for salinity is given in this subsection. The salinity pressure gradient can be included in the equation of motion. The use of SALINITY in combination with DENSITIES or DENSITY (refer to 2.12 or 2.13) couples the transport computation with the flow computation.

Note: The unit for salinity is  $kg/m^3$ .

SALINITY

CO *[iseq]*

### 2.11.1.3 TEMPERATURE (optional)

The constituent number used for temperature is given in this subsection. The temperature can be included in the equation of motion. The use of TEMPERATURE in combination with DENSITIES or DENSITY (refer to 2.12 or 2.13) couples the transport computation with the flow computation.

Refer to HEATMODEL (2.15) for more information about the temperature computation.

Note: The unit for temperature is  $^{\circ}C$ .

TEMPERATURE

CO *[iseq]*

### 2.11.1.4 METHODVARIABLES (optional)

In this subsection the variables related to the numerical method are described.

METHODVARIABLES

THETA = *[val]*

ANTICREEP = *[text]*

ITERTRSP = *[val]*

ITERACCURCONC = *[val]*

ADVEC\_SCHEME = *[val]*

**Explanation:**

- THETA D Coefficient for time integration of the vertical terms in the mass-transport equation.  
 THETA = 1 : Euler implicit time integration  
 THETA = 0.5 : central time integration  
 Meaningful only in TRIWAQ.  
 Limitation:  $0.5 \leq \text{THETA} \leq 1.0$   
 Default = 0.5
- ANTICREEP D Option to include ('on') or exclude ('off') the anti-creep terms due to the use of sigma layers.  
 Default: 'off'.  
 The computation of the anti-creep terms is relatively expensive and may not lead to better results. For compatibility reasons or in cases with relatively large bottom slopes, the value 'on' is advised.
- ITERTRSP=*[ival]* D Maximum number of iterations for the transport equation computations.  
 The default = 50. This should be used in conjunction with an iteration accuracy criterium (ITERACCURCONC) of 0.5E-6.
- ITERACCURCONC=*[val]* D Convergence criterium in transport equation.  
 The standard value is 0.5E-6.
- ADVEC\_SCHEME D Switch for alternative advection scheme.  
 The default value is -1, which means 0 for Waqua and 5 for Triwaq. An alternative advection scheme can be used to avoid negative concentrations, because then limiting can be used. Good results are obtained with ADVEC\_SCHEME is 30 or 31. The value is effectively  $10 \times \text{ILIMIT} + \text{ISCHEME}$ , where ILIMIT and ISCHEME have the following meanings:

	1 <sup>st</sup> half step	2 <sup>nd</sup> half step
ISCHEME = 0	2 <sup>nd</sup> upwind	2 <sup>nd</sup> central (WAQUA default)
ISCHEME = 1	2 <sup>nd</sup> central	2 <sup>nd</sup> central
ISCHEME = 2	1 <sup>st</sup> upwind	1 <sup>st</sup> upwind
ISCHEME = 3	2 <sup>nd</sup> upwind	2 <sup>nd</sup> upwind
ISCHEME = 4	3 <sup>rd</sup> upwind	3 <sup>rd</sup> upwind
ISCHEME = 5	3 <sup>rd</sup> upwind	2 <sup>nd</sup> central (TRIWAQ default)
ILIMIT = 0	no limiter	no limiter (default)
ILIMIT = 1	limiter	no limiter
ILIMIT = 2	no limiter	limiter
ILIMIT = 3	limiter	limiter

### 2.11.1.5 FALL\_VELOCITIES (optional)

In this subsection the fall velocities of the constituents are described. Fall velocities can be used to simulate the behaviour of suspended solids in water. Due to gravity the suspended solids will sink to the bottom.

Fall velocities in combination with the 3d transport solver have effect on the concentrations of the suspended solids in the different layers of the model. However there will be no exchange between the water phase and the bottom. In order to model this phenomenon a user routine (WASUST) must be made.

Fall velocities describe a 3d effect of suspended matter. For this reason this feature has no meaning in combination with the 2d transport solver. However in 2d computation fall velocities can be used in within the user routine WASUST.

#### FALL\_VELOCITIES

<CO [*iseq*]= [*val*]>

Fall velocities are given in  $ms^{-1}$ .

### 2.11.1.6 TURBULENCE\_TRANS (optional)

In this subsection the k- $\epsilon$  turbulence model is set. If omitted an algebraic model (zero order closure) will be employed.

Meaningful only in TRIWAQ.

#### TURBULENCE\_TRANS

ENERGY

DISSIPATION

HOR\_ENERGY

HOR\_DISSIPATION

#### **Explanation:**

ENERGY

- Flag for vertical turbulent kinetic energy k. This specification is only meaningful in combination with keyword DISSIPATION (see below). If omitted an algebraic model is applied.

DISSIPATION

- Flag for dissipation rate of vertical turbulent energy  $\epsilon$ .

HOR\_ENERGY

- Flag for horizontal turbulent kinetic energy k. This specification is only meaningful in combination with keyword HOR\_DISSIPATION (see below).

HOR\_DISSIPATION

- o Flag for dissipation rate of horizontal turbulent energy  $\epsilon$ .

Notes: - The variables ENERGY and DISSIPATION contain KMAX+1 layers in the vertical direction, which are numbered from 0 to KMAX, whereas CONSTITUENTS contain KMAX layers (KMAX is defined in Section 2.6.1.1). It should be noted that the vertical turbulence model can only be applied for KMAX > 1.

- The variables HOR\_ENERGY and HOR\_DISSIPATION are depth-averaged arrays and can also be used if KMAX = 1.
- The variant of vertical k- $\epsilon$  model may be specified by means of the keyword VERT\_VARIANT, for the horizontal k- $\epsilon$  model HOR\_VARIANT can be used (see Section 2.14.4).

## 2.11.2 FORCINGS (mandatory)

In this subsection forcings are set. This subsection is divided in four subsections.

FORCINGS

INITIAL

BOUNDARIES

DISCHARGES

POWERSTATIONS

### 2.11.2.1 INITIAL (optional)

In this subsection initial values are set. INITIAL has three subsections

INITIAL

CONSTITUENT

TURBULENCE\_TRANS

READ\_FROM

### CONSTITUENT (optional)

The initial concentration values are defined separately for every constituent (in the case of TRIWAQ: per constituent for all grid points in each layer). The values for a constituents are given in the data field format (see par. 2.1.2.).

CONSTITUENT

< CO [*iseq*]

GLOBAL (see paragraph 2.1.2.1)

LOCAL (see paragraph 2.1.2.2)

>

**Explanation:**

*co[iseq]* M Constituent number.

**TURBULENCE\_TRANS (optional)**

In this subsection the turbulent kinetic energy  $k$  and dissipation rate  $\epsilon$  are initialised. Meaningful only in TRIWAQ.

TURBULENCE\_TRANSENERGYDISSIPATIONHOR\_ENERGYHOR\_DISSIPATION**Explanation:**

ENERGY O Initial values for vertical turbulent kinetic energy.

ENERGYGLOBAL (see paragraph 2.1.2.1)LOCAL (see paragraph 2.1.2.2)

DISSIPATION O Initial values for dissipation rate of vertical turbulent kinetic energy.

DISSIPATIONGLOBAL (see paragraph 2.1.2.1)LOCAL (see paragraph 2.1.2.2)

HOR\_ENERGY O Initial values for horizontal turbulent kinetic energy.

HOR\_ENERGYGLOBAL (see paragraph 2.1.2.1)LOCAL (see paragraph 2.1.2.2)

HOR\_DISSIPATION O Initial values for dissipation rate of horizontal turbulent kinetic energy

HOR\_DISSIPATION

GLOBAL (see paragraph 2.1.2.1)

LOCAL (see paragraph 2.1.2.2)

- Notes:
- The initial values for ENERGY and DISSIPation are defined for all grid points in each layer. The values are given in the data field format (see Section 2.1.2).
  - If no initial values are defined for either k or  $\epsilon$  (see Subsection 2.11.1.6), then these values are set to  $10^{-7}$ .
  - The variables ENERGY and DISSIPation contain KMAX+1 layers, which are numbered from 0 to KMAX. Initial values specified for the layer number of -1 denotes a uniform vertical distribution.
  - If no initial values are defined for either HOR\_ENERGY and HOR\_DISSIPation (see Subsection 2.11.1.6), then these values are set to  $10^{-2}$  and  $10^{-1}$ , respectively.

**READ\_FROM (optional)**

In the subsection READ\_FROM a SDS-file name, experiment name and time can be specified to read initial concentration fields and turbulence fields from an existing experiment on a SDS-file.

READ\_FROM

EXP\_INITIAL = [text]

SDS\_INITIAL = [text]

TIME\_INITIAL = [val]

REDEFINE\_LAYER\_THICKNESS

**Explanation:**

EXP_INITIAL=[text]	O	Experiment name.
SDS_INITIAL=[text]	M	SDS-file name. The given file name can contain an explicit path name. The use of any indication of a parent directory ('..') is allowed.
TIME_INITIAL=[val]	D	Time (in minutes) in the referred experiment (may differ from TSTART). Map data for this time level must exist on the referred SDS-file. If this keyword is omitted, then the default value TSTART of the new experiment is used; differences between the reference date of the referred and the new experiment are taken into account.



REDEFINE\_LAYER\_THICKNESS

D Flag keyword that allows for redefinition of the layer thicknesses between the old and new experiment. If this flag is specified, the number of layers (KMAX) must be equal in both experiments and three-dimensional variables (e.g. velocities) are copied 1-to-1 from the old layers to the new layers. If this flag is specified here one should also specify the flag at FLOW/FORCINGS/INITIAL/READ\_FROM.

- Notes:
- This option can be used to start a new simulation using data of a previous experiment. The only requirement is that the grid sizes (i.e. MMAX, NMAX and STEPSIZE) are the same. So, in contrast to RESTART, for the READ\_FROM option the reference date (DATE) as defined in TIMEFRAME may differ from the initial reference date as stored in the SDS-file. Only map-data are used for initialization, therefore the presence of restart data in the referred experiment is not required.
  - The simulation mode (WAQUA or TRIWAQ) may vary between the two experiments.
  - If the keyword REDEFINE\_LAYER\_THICKNESS is not specified, the number of layers may vary between the two experiments. However, only layers from the old experiment may be removed and/or layers may be added in the new experiment.
  - The initial condition for a simulation started using this option may differ slightly from the original simulation, as not all initial data are exactly the same as in that simulation. These discrepancies are caused by the fact that the Chezy-values are not updated after each computational step. To obtain initial condition that is exact the same as condition at the specified time-level in previous simulation option RESTART (see section RESTART) should be used.
  - If in the old experiment no horizontal or vertical turbulence model was selected, a turbulence model may be selected in the new experiment. In this case the turbulent energy and dissipation in the new experiment are initialized to  $10^{-7}$ .
  - If EXP\_INITIAL is not specified, the first experiment on the specified SDS file will be taken.

### 2.11.2.2 BOUNDARIES (optional)

The boundary values for the constituents are given in this subsection. Under keyword RETURN\_TIME the constituent return time can be given. For each end point of an opening and each constituent, time series for the concentrations can be given. The pre-processor will take into account the flag SAME (for same conditions at both ends of the opening) that is specified in Section 2.9.1.2 (FLOW, FORCINGS, BOUNDARIES).

If boundaries are specified, then a constituent return time is mandatory for all endpoints of openings.

If no concentration values are given in TIMESERIES for a constituent in a certain point, the boundary conditions for this constituent at this point will be set to zero.

**BOUNDARIES**

```

RETURNTIME :
  <CRET : P [iseq]      TCRETA = [val]>
TIMESERIES
<      TS :   CO [iseq1]   P [iseq2]   SINIT = [val]   SERIES = [text]   LAYER = [ival]
      | FRAME = [val1][val2][val3]
      | VALUES = <[val]>                                     (i.c. series='regular')
<
      | <TIME_AND_VALUE = [tval][val]>
      |                                                         (i.c. series='regular')
>

```

**Explanation:**

TCRETA=[val]	M	Constituent return time in minutes at end of opening after the current reverses to inward flow. This value will be set to the nearest non-zero multiple of TIMESTEP.
CO [iseq]	M	Constituent sequence number
P [iseq2]	M	Point sequence number as defined in MESH, BOUNDARIES, OPENINGS.
CINIT=[val]	M	Initial concentration of constituent [iseq1] at boundary point (dimensionless).
SERIES=[text]	O	SERIES can have two possible values namely: 'regular' or 'irregular'. When SERIES = 'regular' keywords FRAME and VALUES are expected. When SERIES = 'irregular' keyword TIME_AND_CONCENTRATIONS is expected.
LAYER=[ival]	O	Index of the layer where the time series are given. Special case: LAYER = 0 means a uniform boundary condition in the vertical. This information is only meaningful when the keyword BOUXDIM has been given (see Section 2.8.1.10). Limitation: $0 \leq \text{LAYER} \leq \text{KMAX}$ . Default: 0 <b>Note:</b> The time series must be given for each layer.

FRAME=[ <i>val1</i> ] [ <i>val2</i> ] [ <i>val3</i> ]	O	[ <i>val1</i> ] is the first time for which concentrations are given. [ <i>val2</i> ] is the time interval at which concentrations are given. [ <i>val3</i> ] is the last time at which concentrations are given. (These times are given in (elapsed simulation) minutes.)
VALUES= < [ <i>val</i> ] >	O	The values for concentrations are given for the times as defined at the keyword frame (dimensionless).
TIME_AND_VALUES=[ <i>tval</i> ] [ <i>val</i> ]	O	In this case it is possible to give concentrations (dimensionless) at non-equidistant times.

### 2.11.2.3 DISCHARGES (optional)

In this subsection concentrations in sources (defined in section 2.9.1.7) will be given. These discharges must be defined in the same points (and layers, if applicable) as in the FLOW, FORCINGS, DISCHARGES. If the specification of a discharge at certain points are omitted in the TIMESERIES block, the concentrations of the constituents at those points will be set to zero. When discharges are negative (connected to a sink), concentrations which are existing in the model will be used.

#### DISCHARGES

```
<  SOURCE :   CO [iseq2]   P [iseq1]   SERIES =[text]   LAYER =[ival]
      | FRAME = [val1][val2][val3]
      | VALUES = <[val]>                                     (i.c. series='regular')
<
      | <TIME_AND_VALUE = [tval][val]>
      |                                                         (i.c. series='regular')
>
```

#### Explanation:

CO[ <i>iseq2</i> ]	M	Sequence number of constituent.
P[ <i>iseq1</i> ]	M	Point number of constituent
SERIES= <i>[text]</i>	M	SERIES can have two possible values namely: 'regular' or 'irregular'. When SERIES = 'regular' keywords FRAME and VALUES are expected. When SERIES = 'irregular' keyword TIME_AND_VALUES is expected.
LAYER= <i>[ival]</i>	D	Index of the layer where the discharge source is located. Special case: LAYER = 0 means that the discharge is equally distributed in the vertical. This information is only meaningful for TRIWAQ.

- Limitations:  $0 \leq \text{layer} \leq \text{KMAX}$   
 Default: 0
- FRAME=*[val1]* *[val2]* *[val3]*                    O     *[val1]* is the first time for which concentrations are given. *[val2]* is the time interval at which concentrations are given. *[val3]* is the last time at which concentrations are given. (These times are given in (elapsed simulation) minutes.)
- VALUES= < *[val]* >                                    O     The values for concentrations (dimensionless) are given for the times as defined at the keyword frame.
- TIME\_AND\_VALUES=*[tval]* *[val]*                    O     In this case it is possible to give concentrations (dimensionless) at non-equidistant times.

#### 2.11.2.4 POWERSTATIONS (optional)

In this subsection the concentration-changes in powerstations (defined in section 2.6.9) will be given. A positive value means that the concentration of the constituent is increased by the powerstation between the intake and the disposal by the powerstation.

##### POWERSTATIONS

```
<  SOURCE :  CO [iseq2]  POWER [iseq1]  SERIES =[text]
      | FRAME = [val1][val2][val3]
      | VALUES = <[val]>                                     (i.c. series='regular')
<
      | <TIME_AND_VALUE = [tval][val]>
      |
>
```

##### Explanation:

- CO*[iseq2]*    M     Sequence number of constituent.
- POWER*[iseq1]*                                        M     Sequence number of powerstation.
- SERIES=*[text]*                                        M     SERIES can have two possible values namely: 'regular' or 'irregular'. When SERIES = 'regular' keywords FRAME and VALUES are expected. When SERIES = 'irregular' keyword TIME\_AND\_VALUES is expected.
- FRAME=*[val1]* *[val2]* *[val3]*                    O     *[val1]* is the first time for which concentration-changes are given. *[val2]* is the time interval at which changes are given. *[val3]* is the last time at which changes are given. (These times are given in (elapsed simulation) minutes.)

- |                              |   |   |
|------------------------------|---|---|
| VALUES= < [val] >            | O | The values for concentration-changes (dimensionless) are given for the times as defined at the keyword frame. |
| TIME_AND_VALUES=[tval] [val] | O | In this case it is possible to give concentration-changes (dimensionless) at non-equidistant times.           |

### 2.11.3 CHECKPOINTS (optional)

In CHECKPOINTS the constituent stations can be selected. Constituent stations are selected grid points, defined in MESH, at which computed constituent concentration is printed and is saved for histories on the SDS-file. Section 2.6.2 (MESH, POINTS) describes how user points and names can be defined. These points can be referenced here.

Warning: If no constituent stations are defined for TRANSPORT, and if no USECTIONS or VSECTIONS are defined, there will be no history data for the constituents. This could lead to problems during post-processing.

#### CHECKPOINTS

CONSTITUENT\_STATIONS <P [iseq]>

#### **Explanation:**

P[iseq]	M	Numbers of user defined points.
---------	---	---------------------------------

### 2.11.4 USERDATA\_TRANSPORT (optional)

The keyword USERDATA\_TRANSPORT triggers the use of a user routine in the transport module. The application of these user routines is described in the corresponding section of the general information and in the user's guide for the processor WAQPRO. Subsection USERDATA\_TRANSPORT has 7 subsections.

#### USERDATA\_TRANSPORT

CONTROL

REALS

INTEGERS

TIMEFUNCTIONS

INPUT\_SPATIAL\_DATA

TIME\_DEPENDENT\_DATA

OUTPUT\_SPATIAL\_DATA

### 2.11.4.1 CONTROL (mandatory)

In this subsection the length of the work array in the user routine and the type number of the user routine can be given.

#### CONTROL

TYPE = [ival]  
LENWRK = [ival]

#### **Explanation:**

<u>TYPE</u> = [ival]	M	Type number of user routine. A type number $\geq 100$ indicates a standard (included in the mother version) user routine. Type number 0-99 are available for a user routine built by the user.
<u>LENWRK</u> = [ival]	M	Parameter for the length of the work array use in the user routine. The work array has the dimensions <code>WORK(NMAX,-2:MMAX+3,LENWRK)</code> , where <code>(NMAX,-2:MMAX+3)</code> are the dimensions needed for one data field.

### 2.11.4.2 REALS (optional)

In REALS the data array `USER` of `USERDATA_TRANS` in the local data structure can be filled with single real values. Positions that are not used are set to zero.

#### REALS

<USER [iseq]= [val]>

#### **Explanation:**

<u>USER</u> [iseq]= [val]	S	Sequence number of real value, followed by value.
---------------------------	---	---

### 2.11.4.3 INTEGERS (optional)

In INTEGERS the data array `IUSER` of `USERDATA_TRANS` in the local data structure can be filled with single integer values. Positions that are not used are set to zero.

#### INTEGERS

<IUSER [iseq]= [ival]>



## FOURIER (optional)

### FOURIER

#### GENERAL

OMEGA = <[val]>

#### SERIES

<F : ISEQ = [ival]  
AZERO = [val]  
AMPL = <[val]>  
PHASE = <[val]> >

### Explanation:

OMEGA= < [val] >	M	The angular frequencies are given here for N components ( $10^{-4}rads^{-1}$ ).
ISEQ= [ival]	M	Sequence number of Fourier series.
AZERO= [val]	M	Amplitude at point [iseq] for zero frequency (m).
AMPL= < [val] >	M	Sequence of amplitudes for N frequencies at point [iseq] (m).

The function used is:

$$f_i(t) = A_{i0} + \sum_j A_{ij} \cos((\omega \cdot 10^4)t + \varphi_{ij})$$

where:

$f_i(t)$	=	function value, where i is the value of ISEQ
$A_{i0}$	=	amplitude at zero frequency (AZERO)
$j$	=	Fourier component
$A_{ij}$	=	amplitude of the j-th component (AMPL)
$\omega_j$	=	angular frequency of the j-th component (OMEGA)
$\varphi_{ij}$	=	phase of the j-th component (PHASE)

### 2.11.4.5 INPUT\_SPATIAL\_DATA (optional)

In this subsection the input spatial data can be given.

#### INPUT\_SPATIAL\_DATA

< IS [iseq]  
GLOBAL  
LOCAL  
>



**GLOBAL (mandatory)**

Global data can be specified in two ways: first by giving one value for the complete computational grid, second by giving values for each grid point. The order in which these values are to be given is specified by the layout flag.

GLOBAL

```

  LAYOUT = [ival]
  | CONST_VALUES = [val]
<
  | VARIABLE_VALUES = <[val]>

```

**Explanation:**

<u>CONST_VALUES</u> = [val]	O	See paragraph 2.1.2.1 Default = 0
<u>VARIABLE_VALUES</u> = < [val] >	O	See paragraph 2.1.2.1
<u>LAYOUT</u> = [ival]	D	See paragraph 2.1.2.1 Default = 1

**LOCAL (mandatory)**LOCAL

```

<   BOX : MNMN = ([ival],[ival])([ival],[ival])
    | CONST_VALUES = [val]
    <
    | CORNER_VALUES = [val],[val],[val],[val]
    <
    | VARIABLE_VALUES = <[val]>
>

```

**Explanation:**

<u>BOX</u>	R	See paragraph 2.1.2.2
<u>MNMN</u> =( [ival], [ival])( [ival], [ival])	M	See paragraph 2.1.2.2
<u>CONST_VALUES</u> = [val]	O	See paragraph 2.1.2.2
<u>CORNER_VALUES</u> = [val],[val][val],[val]	O	See paragraph 2.1.2.2
<u>VARIABLE_VALUES</u> = < [val] >	O	See paragraph 2.1.2.2

**2.11.4.6 TIME\_DEPENDENT\_DATA (optional)**

In this subsection the time dependent spatial data can be given.

TIME\_DEPENDENT\_DATA

```

<   TDS

```



**Explanation:**

BOX	R	See paragraph 2.1.2.2
MNMN=( <i>ival</i> , <i>ival</i> )( <i>ival</i> , <i>ival</i> )	M	See paragraph 2.1.2.2
CONST_VALUES = <i>val</i>	O	See paragraph 2.1.2.2
CORNER_VALUES= <i>val</i> , <i>val</i> [ <i>val</i> ],[ <i>val</i> ]	O	See paragraph 2.1.2.2
VARIABLE_VALUES = < <i>val</i> >	O	See paragraph 2.1.2.2

**2.11.4.7 OUTPUT\_SPATIAL\_DATA (optional)**

Output spatial data have the same structure as input spatial data. The difference is that output spatial data are written to the SDS file on so-called map times. That is why the possibility exist to give these data a name and a unit that can be used by the post processing.

OUTPUT\_SPATIAL\_DATA

```
<   OS [iseq]
      NAMES
          NAME = [text]
          UNIT = [text]
      GLOBAL      (see paragraph 2.1.2.1)
      LOCAL      (see paragraph 2.1.2.2)
>
```

**Explanation:**

<u>OS</u> [ <i>iseq</i> ]	S	Output spatial data sequence number.
<u>NAMES</u>	O	Each name and unit definition must start with this keyword.
<u>NAME</u> = [ <i>text</i> ]	M	Name of this field. The maximum length of the text for this field is 20 characters.
<u>UNIT</u> = [ <i>text</i> ]	M	Unit of this field. The maximum length of the text for this field is also 20 characters.

## 2.12 DENSITY (optional)

Coefficients for the equation of state can be given here. The keyword DENSITY does the same as DENSITIES, but can do more: by specifying DENSITY it is possible to specify constant (in time) space varying fields for salinity and/or water temperature.

### DENSITY

#### PARAMETERS

CEQSTT = [val]

TEMPWATER = [val]

RHOREF = [val]

SALINITY = [val]

ALFA\_CHEZY = [val]

#### SPACE\_VAR\_SALINITY

##### GLOBAL

###### LAYOUT

| CONST\_VALUES = [val]

<

| VARIABLE\_VALUES = <[val]>

##### LOCAL

< BOX : MNMN = ([ival],[ival])([ival],[ival])

| CONST\_VALUES = [val]

<

| CORNER\_VALUES = [val],[val],[val],[val]

<

| VARIABLE\_VALUES = <[val]>

>

#### SPACE\_VAR\_TEMPWATER

##### GLOBAL

###### LAYOUT

| CONST\_VALUES = [val]

<

| VARIABLE\_VALUES = <[val]>

##### LOCAL

< BOX : MNMN = ([ival],[ival])([ival],[ival])

| CONST\_VALUES = [val]

<

| CORNER\_VALUES = [val],[val],[val],[val]

<

| VARIABLE\_VALUES = <[val]>

>

#### PRESGRAD

##### UDIREC

###### GLOBAL

```

      LAYOUT
      | CONST_VALUES = [val]
    <
      | VARIABLE_VALUES = <[val]>
    LOCAL
<
      BOX : MNMN = ([ival],[ival])([ival],[ival])      LAYER = [ival]
      | CONST_VALUES = [val]
      <
      | CORNER_VALUES = [val],[val],[val],[val]
      <
      | VARIABLE_VALUES = <[val]>
>
VDIREC
  GLOBAL
    LAYOUT
    | CONST_VALUES = [val]
  <
    | VARIABLE_VALUES = <[val]>
  LOCAL
<
    BOX : MNMN = ([ival],[ival])([ival],[ival])      LAYER = [ival]
    | CONST_VALUES = [val]
    <
    | CORNER_VALUES = [val],[val],[val],[val]
    <
    | VARIABLE_VALUES = <[val]>
>

```

**Explanation:**

CEQSTT=[val]	D	Is a constant in the equation of state (WAQUA: ALPH0). Default = 0.698
TEMPWATER=[val]	D	Water temperature in the equation of state (° C). Default = 14.0
RHOREF=[val]	D	Reference density (kg l <sup>-1</sup> ). Default = 1.0
SALINITY=[val]	D	Salinity of water (kg m <sup>3</sup> ). Default = 0.0
ALFA_CHEZY=[val]	D	Coefficient ( $\alpha$ ) used in the correction of the Chezy values for the salinity gradients. This coefficient must be $\geq 0$ . Default = 0.0 (i.e. no correction of the Chezy values)
SPACE_VAR_SALINITY	O	If this keyword is given, a constant field in time for salinity can be specified.

SPACE_VAR_TEMPWATER	O	If this keyword is given, a constant field in time for water temperature can be specified.
PRESGRAD	O	If this keyword is given, a constant field in time for the pressure gradient due to density can be specified ( $\text{ms}^{-2}$ ). In this case the density gradient terms will not be computed anymore.
UDIREC	M	Pressure gradient term in u direction
VDIREC	M	Pressure gradient term in v direction
BOX	R	See paragraph 2.1.2.2
MNMN=( <i>ival</i> , <i>ival</i> )( <i>ival</i> , <i>ival</i> )	M	See paragraph 2.1.2.2
LAYER = <i>ival</i>	O	See paragraph 2.1.2.2
CONST_VALUES = <i>val</i>	O	See paragraph 2.1.2.2
VARIABLE_VALUES = < <i>val</i> >	O	See paragraph 2.1.2.2
CORNER_VALUES = <i>val</i> , <i>val</i> , <i>val</i> , <i>val</i>	O	See paragraph 2.1.2.2

- Notes:
- There are three options to specify salinity. As a constant value for the whole field, as a special constituent or as a space varying field. It is only allowed to use one of the three options because of ambiguity.
  - There are three options to specify temperature. As a constant value for the whole field, as a special constituent or as a space varying field. It is only allowed to use one of the three options because of ambiguity.
  - If  $\text{ALFA\_CHEZY} \geq 0$  is specified, the value of the Chezy friction coefficient in each grid point will be corrected for the local salinity gradient. This correction will be performed before each half time step of the simulation. One of constituents must be defined as salinity (see also section 2.11.1.2). For the description of the correction procedure refer to: WAQUA User's Guide, General Information part.
  - In the program the value of the specified  $\text{ALFA\_CHEZY}$  will be multiplied by factor 1000.
  - It is not allowed to use  $\text{DENSITIES}$  and  $\text{DENSITY}$  at the same time.
  - If  $\text{PRESGRAD}$  is specified, it is mandatory to specify a field in the U and the V direction. This should be terms of the order  $\text{ms}^{-2}$ .
  - It is not allowed to use the  $\text{PRESGRAD}$  option and  $\text{SPACE\_VAR}$  fields at the same time.

## 2.13 DENSITIES (optional)

Coefficients for the equation of state are given here. By specifying keyword DENSITIES user indicates that the computation of flow is to be coupled with the computation of transport by means of equation of state (refer to WAQUA User's Guide, General Information part). See also section 2.11.1.2.

### DENSITIES

CEQSTT = [val]      TEMPWATER = [val]      RHOREF = [val]  
SALINITY = [val]  
ALFA\_CHEZY = [val]

### Explanation:

<u>CEQSTT</u> =[val]	D	Is a constant in the equation of state (WAQUA: ALPH0). Default = 0.698
<u>TEMPWATER</u> =[val]	D	Water temperature in the equation of state (° C). Default = 14.0
<u>RHOREF</u> =[val]	D	Reference density (kg l <sup>-1</sup> ). Default = 1.0
<u>SALINITY</u> =[val]	D	Salinity of water (kg m <sup>-3</sup> ). Default = 0.0
<u>ALFA_CHEZY</u> =[val]	D	Coefficient ( $\alpha$ ) used in the correction of the Chezy values for the salinity gradients. This coefficient must be $\geq 0$ . Default = 0.0 (i.e. no correction of the Chezy values)

- Notes:
- DENSITIES is an old keyword. The new keyword DENSITY (See Section 2.12) can do the same and even more. It is not allowed to use DENSITIES and DENSITY at the same time.
  - It is also possible to use a constant (in time) field instead of a scalar for salinity or tempwater, but then DENSITY should be used.
  - If the salinity is defined as a special constituent, the specification of constant salinity is not allowed because of ambiguity.
  - If  $\text{ALFA\_CHEZY} \geq 0$  is specified, the value of the Chezy friction coefficient in each grid point will be corrected for the local salinity gradient. This correction will be performed before each half time step of the simulation. One of constituents must be defined as salinity (see also section 2.11.1.2). For the description of the correction procedure refer to: WAQUA User's Guide, General Information part.
  - In the program the value of the specified ALFA\_CHEZY will be multiplied by factor 1000.

## 2.14 TURBULENCE\_MODEL (optional)

In this section the turbulence model (relevant for TRIWAQ) will be defined. This section consists of 7 subsections. If this keyword is omitted, all the defaults, as described below, will be used.

TURBULENCE\_MODEL

WALL\_DEFINITION

VERTVISCOSITY

VERTDIFFUSION

VERT\_VARIANT

HOR\_VARIANT

HLES

EMPIRICAL\_CONSTANTS

### 2.14.1 WALL\_DEFINITION (optional)

In this subsection (relevant only for TRIWAQ) the wall type is defined.

WALL\_DEFINITION

| ROUGH

<

| SMOOTH

#### Explanation:

SMOOTH	○	If specified, smooth wall type will be used
ROUGH	○	If specified, rough wall type will be used

- Notes:
- Specification of wall type is allowed only if the parabolic vertical viscosity profile is used (refer to subsection 2.14.2).
  - If the keyword WALL\_DEFINITION is specified in the input, it must be followed by specification of either SMOOTH or ROUGH wall type.
  - If the keyword WALL\_DEFINITION is not specified in the input, the rough wall type will be used.

### 2.14.2 VERTVISCOSITY (optional)

In this subsection the vertical eddy viscosity profile and related parameters are defined. VERTVISCOSITY consists of 2 parts:

VERTVISCOSITY

CONSTANT



PARABOLIC

- Notes:
- If the keyword VERTVISCOSITY is specified in the input, it must be followed by either CONSTANT or PARABOLIC.
  - If the keyword VERTVISCOSITY is not specified in the input, parabolic vertical viscosity will be used.

**2.14.2.1 CONSTANT (optional)**

In this subsection the constant (i.e. uniform) vertical eddy viscosity profile can be defined. Uniform vertical viscosity is allowed in TRIWAQ.

CONSTANT

$$\underline{\text{VVISCOSITY}} = [val]$$

**Explanation:**

$\text{VVISCOSITY}=[val]$	D	Constant vertical eddy viscosity coefficient. Default = 0.0
---------------------------	---	--

**2.14.2.2 PARABOLIC (optional)**

In this subsection the parabolic vertical eddy viscosity profile and related parameters can be defined. This definition is allowed only in TRIWAQ.

PARABOLIC

$$\underline{\text{VFACTOR}} = [val]$$

$$\underline{\text{VINITIAL}} = [val]$$

LRICH

**Explanation:**

$\text{VFACTOR} = [val]$	D	Factor on parabolic vertical eddy viscosity profile. Default = 0.58
$\text{VINITIAL} = [val]$	D	Initial value for the vertical eddy viscosity coefficients. Default = 0.0
LRICH	D	Flag: if specified, the Richardson number will be used for damping of vertical eddy viscosity and diffusion coefficients due to density gradients.

Limitation: this option can be used only if one of the constituents is defined as SALINITY or TEMPERATURE.

Default: the Richardson number will not be used for damping of vertical eddy viscosity and diffusion coefficients due to density gradients.

### 2.14.3 VERTDIFFUSION (optional)

In this subsection the vertical diffusion profile and related parameters are defined. VERTDIFFUSION consists of 2 parts:

VERTDIFFUSION

CONSTANT

PARABOLIC

- Notes:
- If the keyword VERTDIFFUSION is specified in the input, it must be followed by either CONSTANT or PARABOLIC.
  - If the keyword VERTDIFFUSION is not specified in the input, constant vertical diffusion will be used.

#### 2.14.3.1 CONSTANT (optional)

In this subsection the constant (i.e. uniform) vertical diffusion profile can be defined. Uniform vertical diffusion is allowed in TRIWAQ.

CONSTANT

VDIFFUSION = [val]

#### Explanation:

VDIFFUSION= [val]

D      Constant vertical diffusion coefficient.  
Default = 0.0

#### 2.14.3.2 PARABOLIC (optional)

In this subsection the parabolic vertical diffusion profile and related parameters can be defined. This definition is allowed only in TRIWAQ and only if the parabolic vertical viscosity is also specified in the input. In this subsection formulas for the computation of vertical viscosity and diffusion are defined. At this moment only one formula (Munk-Anderson) is available. Also the Prandtl-Schmidt number, that will be used in the case of no stratification, can be given here.

PARABOLICMUNK\_ANDERSON  
PRANDTL\_SCHMIDT**MUNK\_ANDERSON (mandatory)**

The parameters in the Munk-Anderson formula for vertical viscosity and diffusion are defined here.

MUNK\_ANDERSONALFAA = [val]  
BETAA = [val]  
ALFAB = [val]  
BETAB = [val]**Explanation:**

<u>ALFAA</u> = [val]	D	Exponent in the Munk-Anderson formula for vertical viscosity Default = 0.5
<u>BETAA</u> = [val]	D	Base number in the Munk-Anderson formula for vertical viscosity Default = 10.0
<u>ALFAB</u> = [val]	D	Exponent in the Munk-Anderson formula for vertical diffusion Default = 1.5
<u>BETAB</u> = [val]	D	Base number in the Munk-Anderson formula for vertical diffusion Default = 3.33

**PRANDTL\_SCHMIDT (optional)**

The Prandtl-Schmidt number for the case of no stratification is defined here.

PRANDTL\_SCHMIDT  
DEFPSN = [val]**Explanation:**

<u>DEFPSN</u> = [val]	D	Prandtl-Schmidt number. Default = 0.7.
-----------------------	---	---

### 2.14.4 VERT\_VARIANT (optional)

In this subsection the variant of vertical k- $\epsilon$  model can be defined. If omitted the standard k- $\epsilon$  model will be employed. This definition is allowed only if the keyword TURBULENCE\_TRANS has been specified (see Section 2.11.1.6). VERT\_VARIANT must be followed by one of the following subkeywords:

```
VERT_VARIANT
  | STANDARD
  <
  | RNG
  <
  | EXTENDED
```

#### Explanation:

STANDARD	○	If specified, the standard vertical k- $\epsilon$ model will be used
RNG	○	If specified, the RNG vertical k- $\epsilon$ model will be used
EXTENDED	○	If specified, the extended vertical k- $\epsilon$ model will be used

Notes: - The variants RNG and EXTENDED may only be selected in combination with non-hydrostatic computations. See keyword HYDRODYNAMIC in paragraph 2.10.

### 2.14.5 HOR\_VARIANT (optional)

In this subsection the variant of horizontal k- $\epsilon$  model can be defined. If omitted the standard k- $\epsilon$  model will be employed. This definition is allowed only if the keyword TURBULENCE\_TRANS has been specified (see Section 2.11.1.6). HOR\_VARIANT must be followed by one of the following subkeywords:

```
HOR_VARIANT
  | STANDARD
  <
  | RNG
  <
  | EXTENDED
```

#### Explanation:

STANDARD	O	If specified, the standard horizontal k- $\epsilon$ model will be used
RNG	O	If specified, the RNG horizontal k- $\epsilon$ model will be used
EXTENDED	O	If specified, the extended horizontal k- $\epsilon$ model will be used

## 2.14.6 HLES (optional)

In this subsection the input for the viscosity turbulence model HLES can be given. HLES stands for Horizontal Large Eddy Simulation and simulates a turbulent flow by adapting the effective viscosity and diffusivity. HLES has the following subkeywords:

### HLES

TFHLES

TLHLES

SLOPE

DIMENSION

PRANDTL\_SCHMIDT

LOWPASS

RELAXATION

MOL\_DIFFUSIVITY

NO\_ELDER

LIMIT\_VISC

### Explanation:

TFHLES= <i>[val]</i>	D	Time first that the HLES calculation is done. Default = TSTART
TLHLES= <i>[val]</i>	D	Time last that the HLES calculation is done. Default = TSTOP
SLOPE= <i>[val]</i>	D	Slope in log-log spectrum (range: [1,3]). Default = 1.666666
DIMENSION= <i>[ival]</i>	D	Dimension Number. In the current version this number must be 2. Default = 2
PRANDTL_SCHMIDT= <i>[val]</i>	D	Prandtl-Schmidt number (range: [0.5,1]). Default = 0.7
LOWPASS= <i>[val]</i>	D	Spatial low-pass filter coefficient (range: [0.2,1]). Default = 0.333333
RELAXATION= <i>[val]</i>	D	Relaxation time in minutes (range: $\geq 0.0$ or equal to -1 for no relaxation). Default = -1.0
MOL_DIFFUSIVITY= <i>[val]</i>	D	Molecular diffusivity (range $\geq 0.0$ ).

		Default = 0.0
NO_ELDER	O	If specified, Elder correction will not be used.
LIMIT_VISC	D	Limitation of computed viscosity. Default = 99.0

Notes: The following rules apply for using HLES.

- HLES can not be used in combination with the depth averaged horizontal k-epsilon turbulence model. Therefore, if HLES is used the keywords HOR\_VARIANT, HOR DISSIP and HOR\_ENERGY may not be used.
- HLES can only be used in 2D simulations, e.g. WAQUA or TRIWAQ with kmax = 1.
- To avoid stability problems, a limitation of e.g. LIMIT\_VISC = 4.0 can be given.
- HLES is driven by differences in velocity. Therefore the computation of the velocity should be accurate; this can be checked by running your model two times, and use in the second run the option Quantf\_Random (see section 2.8.1.2).
- HLES is calculated every half time step between TFHLES and TLHLES.

## 2.14.7 EMPIRICAL\_CONSTANTS (optional)

In this subsection the empirical constants used in the horizontal and vertical k- $\epsilon$  model and also in the log wall-law can be specified. The default closure constants used are those that are commonly accepted in the literature. However, the user has the option to use his own constants in the k- $\epsilon$  model or wall-law. The following constants are available:

### EMPIRICAL\_CONSTANTS

KAPPA = [val]  
E\_SMOOTH = [val]  
C\_MU = [val]  
SIGMA\_K = [val]  
SIGMA\_EPS = [val]  
CEPS\_ONE = [val]  
CEPS\_TWO = [val]  
ETA\_ZERO = [val]  
GAMMA = [val]  
CEPS\_THREE = [val]  
HOR\_C\_MU = [val]  
HOR\_SIGMA\_K = [val]  
HOR\_SIGMA\_EPS = [val]  
HOR\_CEPS\_ONE = [val]  
HOR\_CEPS\_TWO = [val]  
HOR\_ETA\_ZERO = [val]  
HOR\_GAMMA = [val]  
HOR\_CEPS\_THREE = [val]

BREAKING\_WAVESFV = [val]**Explanation:**

KAPPA = [val]	D	The Von Karman constant Limitation: $0.40 \leq \text{KAPPA} \leq 0.42$ Default = 0.41
E_SMOOTH = [val]	D	Constant needed for the modelling of turbulent flow near a hydraulically smooth wall (“law of the wall”) Limitation: $7.45 \leq \text{E\_SMOOTH} \leq 10.0$ Default = 8.43
C_MU = [val]	D	Constant used for the vertical k- $\epsilon$ model Limitation: $0.01 \leq \text{C\_MU} \leq 0.36$ Default = 0.09
SIGMA_K = [val]	D	Constant used for the equation of vertical turbulent kinetic energy k Limitation: $0.70 \leq \text{SIGMA\_K} \leq 1.40$ Default = 1.0
SIGMA_EPS = [val]	D	Constant used for the equation of vertical dissipation rate $\epsilon$ Limitation: $0.70 \leq \text{SIGMA\_EPS} \leq 1.40$ Default = 1.3
CEPS_ONE = [val]	D	Constant used for the equation of vertical dissipation rate $\epsilon$ Limitation: $1.00 \leq \text{CEPS\_ONE} \leq 1.55$ Default = 1.44
CEPS_TWO = [val]	D	Constant used for the equation of vertical dissipation rate $\epsilon$ Limitation: $1.50 \leq \text{CEPS\_TWO} \leq 2.00$ Default = 1.92

Note: The default values mentioned above are associated with the standard vertical k- $\epsilon$  model. In case of vertical RNG model, the following values should be used:

C\_MU = 0.085  
 SIGMA\_K = 0.7179  
 SIGMA\_EPS = 0.7179  
 CEPS\_ONE = 1.42  
 CEPS\_TWO = 1.68

In case of vertical extended model, the following values should be used:

C\_MU = 0.09  
 SIGMA\_K = 0.75  
 SIGMA\_EPS = 1.15  
 CEPS\_ONE = 1.35  
 CEPS\_TWO = 1.9

The constants will be set according to the above mentioned values as soon as the vertical RNG or extended model is used (see Section 2.14.4).

**Explanation:**

ETA_ZERO = [val]	D	Constant used for the vertical RNG k-ε model Limitation: $2.0 \leq \text{ETA\_ZERO} \leq 16.0$ Default = 4.38
GAMMA = [val]	D	Constant used for the vertical RNG k-ε model Limitation: $0.01 \leq \text{GAMMA} \leq 0.015$ Default = 0.012
CEPS_THREE = [val]	D	Constant used for the vertical extended model Limitation: $0.00 \leq \text{CEPS\_THREE} \leq 0.40$ Default = 0.05
HOR_C_MU = [val]	D	Constant used for the standard horizontal k-ε model Limitation: $0.01 \leq \text{HOR\_C\_MU} \leq 0.36$ Default = 0.09
HOR_SIGMA_K = [val]	D	Constant used for the equation of horizontal turbulent energy k Limitation: $0.70 \leq \text{HOR\_SIGMA\_K} \leq 1.40$ Default = 1.0
HOR_SIGMA_EPS = [val]	D	Constant used for the equation of horizontal dissipation rate ε Limitation: $0.70 \leq \text{HOR\_SIGMA\_EPS} \leq 1.40$ Default = 1.3
HOR_CEPS_ONE = [val]	D	Constant used for the equation of horizontal dissipation rate ε Limitation: $1.00 \leq \text{HOR\_CEPS\_ONE} \leq 1.55$ Default = 1.44
HOR_CEPS_TWO = [val]	D	Constant used for the equation of horizontal dissipation rate ε Limitation: $1.50 \leq \text{HOR\_CEPS\_TWO} \leq 2.00$ Default = 1.92



Note: The default values mentioned above are associated with the standard horizontal k- $\epsilon$  model. In case of RNG model, the following values should be used:

HOR\_C\_MU = 0.085  
 HOR\_SIGMA\_K = 0.7179  
 HOR\_SIGMA\_EPS = 0.7179  
 HOR\_CEPS\_ONE = 1.42  
 HOR\_CEPS\_TWO = 1.68

In case of extended model, the following values should be used:

HOR\_C\_MU = 0.09  
 HOR\_SIGMA\_K = 0.75  
 HOR\_SIGMA\_EPS = 1.15  
 HOR\_CEPS\_ONE = 1.35  
 HOR\_CEPS\_TWO = 1.9

The constants will be set according to the above mentioned values as soon as the horizontal RNG or extended model is used (see Section 2.14.5).

HOR_ETA_ZERO = [val]	D	Constant used for the horizontal RNG k- $\epsilon$ model Limitation: $2.0 \leq \text{HOR\_ETA\_ZERO} \leq 16.0$ Default = 4.38
HOR_GAMMA = [val]	D	Constant used for the horizontal RNG k- $\epsilon$ model Limitation: $0.01 \leq \text{HOR\_GAMMA} \leq 0.015$ Default = 0.012
HOR_CEPS_THREE = [val]	D	Constant used for the horizontal extended model Limitation: $0.00 \leq \text{HOR\_CEPS\_THREE} \leq 0.40$ Default = 0.05
BREAKING_WAVES	D	BREAKING_WAVES is a flag keyword. If this keyword is specified then an eddy viscosity model for breaking waves is used. Default = no breaking_waves.
FV = [val]	O	Empirical constant in eddy viscosity model for breaking waves.

## 2.15 HEATMODEL (optional)

In this section the heatmodel (relevant for the temperature model) will be defined.

### HEATMODEL

```
| HEATEXCHANGE
|   SWEERS
<
| HEATBALANCE
|   | LUDIKHUIZEN
|     | BOWEN_RATIO = [val]
|     | GIVEN_RADIATION
|     | SOLAR_REFLECTION = [val]
|   <
|     | DEGOEDE
|       | THERMALEMISSIV = [val]
|       | STANTON = [val]
|       | DALTON = [val]
|   SWEERS_WIND
|     | A_FIT = [val]
|     | B_FIT = [val]
|     | POWER = [val]
|     | AREAWATER = [val]
|   BACK_TEMPERATURE
|     | TUNIT = [text]
|       | TEMPERATURE = [val]
|     <
|       | SERIES = [text]
|         | FRAME = [val1][val2][val3]
|         | VALUES = <[val]> (i.c. series='regular')
|       <
|         | <TIME_AND_VALUE = [tval][val]> (i.c. series='regular')
```

Note: The wind for the HEATMODEL is taken from the section GENERAL/WIND or GENERAL/SPACE\_VAR\_WIND.

### 2.15.1 HEATEXCHANGE (optional)

In this subsection heat exchange is specified.

HEATEXCHANGE  
SWEERS

**Explanation:**

SWEERS

M

The SWEERS model will be used

**2.15.2 HEATBALANCE (optional)**

In this subsection the heat balance module and related parameters at the watersurface are defined.

HEATBALANCE

```
| LUDIKHUIZEN
<
| DEGOEDE
```

**2.15.2.1 LUDIKHUIZEN (optional)**

In this subsection the Ludikhuizen model can be specified.

BOWEN\_RATIO = [val]GIVEN\_RADIATIONSOLAR\_REFLECTION = [val]**Explanation:**BOWEN\_RATIO= [val]

D

Ratio of the difference between air and water.  
Default = 0.65GIVEN\_RADIATION

O

Given solar radiation. If specified, the values given under METEO\_DATA and SOLAR\_IRRADIATION will be used as the net radiation (atmospherical and solar radiation are combined)

SOLAR\_REFLECTION= [val]

D

Reflection coefficient  $\alpha$  on watersurface and suspended material.  
Default = 0.06**2.15.2.2 DEGOEDE (optional)**

In this subsection the model of De Goede can be specified.

THERMALEMISSIV = [val]STANTON = [val]DALTON = [val]

**Explanation:**

$THERMAL\_EMISSIV=[val]$	D	Thermal emissivity from the surface. Default = 0.985
$STANTON=[val]$	D	Stanton number; amount which scales the effect from difference in temperature between air and water. Default = 0.00145
$DALTON=[val]$	D	Dalton number; amount which scales the energy lost via evaporation. Default = 0.0015

**2.15.3 SWEERS\_WIND (optional)**

In this subsection the wind function of Sweers can be specified

$A\_FIT = [val]$   
 $B\_FIT = [val]$   
 $POWER = [val]$   
 $AREAWATER = [val]$

**Explanation:**

$A\_FIT=[val]$	D	Fitting constant dependent on the location (water, land or height) of the wind data. Default=3.5
$B\_FIT=[val]$	D	Fitting constant dependent on the location (water, land or height) of the wind data. Default=2.05
$POWER=[val]$	D	Prefactor in heat loss model. Should be omitted when applying on Noordzeekanaal. Default=0.05
$AREAWATER=[val]$	D	Background area in m <sup>2</sup> . Default=100 x 10 <sup>6</sup> m <sup>2</sup> .

**2.15.4 BACK\_TEMPERATURE (optional)**

In this subsection the background temperature and related parameters are defined.

$BACK\_TEMPERATURE$   
 $\quad TUNIT = [text]$   
 $\quad | \quad TEMPERATURE = [val]$   
 $\quad <$

```

| SERIES = [text]
|   | FRAME = [val1][val2][val3]
|   | VALUES = <[val]>
|   <
|   | <TIME_AND_VALUE = [tval][val]>
|   |

```

(i.c. series='regular')

(i.c. series='regular')

**Explanation:**

- |                             |   |  |
|-----------------------------|---|--|
| TUNIT=[text]                | O | Name of the background temperature unit to display in eg. degrees Celcius ( $^{\circ}\text{C}$ ).  |
| TEMPERATURE=[val]           | D | Background air temperature in degrees Celcius. The background temperature is a constant value.<br>Default=20 $^{\circ}\text{C}$ .  |
| SERIES=[text]               | O | SERIES can have two possible values: 'regular' or 'irregular'. When SERIES = 'regular' keywords FRAME and VALUES are expected. When SERIES = 'irregular' keyword TIME_AND_VALUES is expected.  |
| FRAME=[val1] [val2] [val3]  | O | [val1] is the first time for which the background temperature is given.<br>[val2] is the time interval at which background temperature is given.<br>[val3] is the last time at which background temperature is given. (All these times are given in minutes) |
| VALUES= [val]               | O | The values for background temperature (dimension: See TUNIT) are given for the times as defined at the keyword frame.  |
| TIME_AND_VALUES=[tval][val] | O | In this case it is possible to give background temperature at non-equidistant times.   |

## 2.16 DISPLAYS (optional)

In section DISPLAYS graphics output is controlled. It is only meaningful for rectilinear postprocessing. DISPLAY is divided in eight subsections.

### DISPLAYS

GRIDDISP

OUTLINES

TITLE

LEGEND

POSCLOCK

WINDARROW

PERMTITLES

ISOLINES

### 2.16.1 GRIDDISP (optional)

In this subsections the margins of the display are defined. XLEFTMARG, XRIGHTMARG, YBOTMARG and YTOPMARG are the margins around the grid in displays. XRIGHTMARG and YTOPMARG are minimum margins on the right and top, so that the grid is not distorted away from RATIODXDY.

RATIODXDY is the ratio of DX to DY, that is the ratio between the width and height of a grid space on displays.

#### GRIDDISP

<u>XLEFTMARG</u> = [val]	<u>XRIGHTMAR</u> = [val]
<u>YBOTMARG</u> = [val]	<u>YTOPMARG</u> = [val]
<u>RATIODXDY</u> = [val]	

#### **Explanation:**

XLEFTMARG=[val]	D	8.0 grid space units
XRIGHTMAR=[val]	D	8.0 grid space units
YBOTMARG=[val]	D	8.0 grid space units
YTOPMARG=[val]	D	8.0 grid space units
RATIODXDY=[val]	D	1.0

### 2.16.2 OUTLINES (optional)

In this subsection boundary outlines are defined. This section has 2 subsections

#### OUTLINES

GENERAL

LINES**2.16.2.1 GENERAL (optional)**

In this subsection the parameters for the adjustment of the position of all land boundary outlines are given, in grid units. Normally XSHIFT = 0.0 and YSHIFT = 0.0, unless a correction for the outlines is wanted because of a different previously used reference point, or inaccurately positioned outlines.

GENERAL

$$\underline{\text{XSHIFT}} = [val] \quad \underline{\text{YSHIFT}} = [val]$$
**Explanation:**

- |                       |   |   |
|-----------------------|---|---|
| $\text{XSHIFT}=[val]$ | ○ | Shift in X-direction expressed in M grid units. |
| $\text{YSHIFT}=[val]$ | ○ | Shift in Y-direction expressed in N grid units. |

**2.16.2.2 LINES (optional)**

Boundary outlines are defined in this section.

LINES

$$\langle \underline{\text{L}} : \underline{\text{LINETYPE}} = ([val1], [val2], [val3]) \\ \underline{\text{COORD}} = \langle ([val1], [val2]) \rangle \rangle$$
**Explanation:**

- |   |   |  |
|---|---|--|
| $\text{LINETYPE}=( [val1], [val2], [val3] )$      | ○ | Line type of boundary outline:<br>$[val1]$ is the normalized line width.<br>$[val2]$ is the dash length (in grid units).<br>$[val3]$ is the space length between dashes (in grid units). If $[val3]$ is zero the line will be solid. |
| $\text{COORD} = \langle ([val1], [val2]) \rangle$ | ○ | Is a series of (M, N) coordinates for the boundary outlines. M and N are real values.  |

**2.16.3 TITLE (optional)**

In this subsection the position (FX, FY) (in grid units), character size CHARSIZE (= default 1.0) and the title TEXT (maximum of 72 characters) of the title that is displayed on maps is given.

TITLE

FX = [val]  
FY = [val]  
CHARSIZE = [val]  
TEXT = [text]

**Explanation:**

FX=[val], fy=[val]	D	(M, N) position of TITLE. Default (1, 1)
CHARSIZE=[val]	D	Character size in TITLE. Default = 1.5
TEXT=[text]	O	A maximum of 72 characters.

### 2.16.4 LEGEND (optional)

The legend is defined in this section

LEGEND

FX = [val]  
FY = [val]  
CHARSIZE = [val]  
ISOFORMAT = [val]  
ISOCOL = [val]

**Explanation:**

FX=[val], fy=[val]	D	(M, N) position of legend Default (1, 1)
CHARSIZE=[val]	D	Character size in legend. See also TITLE. Default = 1.5
ISOFORMAT=[val]	D	is a code for the format of isoline values in the legend. (See FMTISO in WAQUA IDP user's Guide.) Default = 2
ISOCOL=[val]	D	Number of columns of isoline values to display in the legend on maps.

### 2.16.5 POSCLOCK (optional)

Parameters for plotting of a clock on maps are given in this subsection.



**POSCLOCK** $\underline{\text{FX}} = [val]$  $\underline{\text{FY}} = [val]$  $\underline{\text{CHARSIZE}} = [val]$  $\underline{\text{CLOCKRAD}} = [val]$ **Explanation:**

$\text{FX}=[val], \text{fy}=[val]$	D	(M, N) position of the centre of the clock on maps. Default = (1, 1)
$\text{CHARSIZE}=[val]$	D	Character size. See also TITLE. Default = 0.75
$\text{CLOCKRAD}=[val]$	D	Radius of the clock, in grid space units Default = 1.0

**2.16.6 WINDARROW (optional)**

Parameters for plotting of north direction and wind arrow on maps are given in this subsection.

**WINDARROW** $\underline{\text{FX}} = [val]$  $\underline{\text{FY}} = [val]$  $\underline{\text{CHARSIZE}} = [val]$  $\underline{\text{LENGTH}} = [val]$  $\underline{\text{VECTWIDTH}} = [val]$ **Explanation:**

$\text{FX}=[val], \text{fy}=[val]$	D	(M, N) position of the north and wind arrow on maps. Default = (1, 1)
$\text{CHARSIZE}=[val]$	D	Character size. See also TITLE. Default = 0.75
$\text{LENGTH}=[val]$	D	Length of the north direction arrow (in grid space units). Default = 1.0
$\text{VECTW}=[val]$	D	The number of units of wind speed corresponding to a vector as long as the width of a grid space unit, on displays. Default = 10.0

## 2.16.7 PERMTITLES (optional)

Permanent titles may be given, to be displayed on maps. Usually these titles will be geographical names, for orientation of the displayed computational results.

### PERMTITLES

<T : XPOS = [val]      YPOS = [val]      SIZE = [val]  
                  WIDTH = [val]      ANGLE = [val]      TITLE = [text] >

### Explanation:

<u>XPOS</u> = [val], <u>ypos</u> = [val]	M	(M, N) position of title.
<u>SIZE</u> = [val]	D	Normalized character size of title. Default = 1.0
<u>WIDTH</u> = [val]	D	Normal line width of title. Default = 1.0
<u>ANGLE</u> = [val]	D	Orientation of the title line. 0 is horizontal, 90 is vertical. Default = 0.0
<u>TITLE</u> = [text]	M	Title. Maximum length is 28.

## 2.16.8 ISOLINES (optional)

Lines which connect coordinates with equal values  
(e.g. velocity, waterlevel, mass transport, constituents)

### ISOLINES

SONUM = [val]  
MGRID = [ival]

### Explanation:

<u>SIZEISONUM</u> [val]	D	Character size for displaying ISOLINES values. Default = 1.0
<u>ISONUMGRID</u> [ival]	D	Grid interval for display of ISOLINES sequence numbers. Default = 2

## 2.17 SDSOUTPUT (optional)

In this section the times for writing map-data, time history-data, restart data and derived output-data (time-integrals, harmonic analyses, minimum/maximum values, incremental class-changes for making animations) is controlled. SDSOUTPUT has nine subsections

### SDSOUTPUT

MAPS

HISTORIES

INTEGRATION

RESTART

HARMONIC\_TIDE

KALMAN\_HISTORIES

CALCMAXVALUES

CALCMINVALUES

INCREMENTAL

Notes: The following rules apply to all types of data that can be specified with the command SDSOUTPUT, except HARMONIC\_TIDE.

- no data will be written to the SDS file unless at least Time Interval has been specified in the input;
- if either Time first or Time last (or both) are specified, Time interval must be specified;
- if at least Time interval has been specified, two default values are applicable:

Time first = Tstart and

Time last = Tstop;

- when CALCMAXVALUES and CALCMINVALUES are used, the time interval is not mandatory and defaults to Tstep;
- in the current version of WAQUA the data needed to calculate the mass balance is present within the computational routines only, and is not presented in the history data.

The program will check whether:

- time interval is a multiple of Time step of the simulation;
- the specified values are within the simulation frame;
- times to write data coincide with end of a simulation step.

If necessary, the time values specified by the user will be corrected to fulfil the conditions stated above.

## 2.17.1 MAPS (optional)

In this subsection time first, time interval and time last to write map-data to the SDS-file are specified.

### MAPS

TFMAPS = *[val]*      TIMAPS = *[val]*      TLMAPS = *[val]*  
TMAPS = *[vals]*  
NO\_SCREENS  
NO\_VELOCITIES  
NO\_CHEZY  
NO\_TOTAL\_WATER\_DEPTH  
NO\_TRANSPORT  
TURBULENCE  
WEIRS  
HYDRO  
VISCOSITY  
WIND  
PRESSURE

### Explanation:

<u>TFMAPS</u> = <i>[val]</i>	O	Time first to write map-data to SDS-file.
<u>TIMAPS</u> = <i>[val]</i>	O	Time interval to write map-data to SDS-file.
<u>TLMAPS</u> = <i>[val]</i>	O	Time last to write map-data to SDS-file. (All times in elapsed simulation minutes)
<u>TMAPS</u> =< <i>[vals]</i> >	O	List of additional timelevels to write map-data to SDS-file. An arbitrary number of times can be given here. (All times in elapsed simulation minutes)
<u>NO_SCREEN</u> S	D	Specifies whether screen arrays will be written to SDS-file. Default: screens will be written.
<u>NO_VELOCITIES</u>	D	Specifies whether velocity map arrays will be written to SDS-file. Default: velocity map arrays will be written.
<u>NO_CHEZY</u>	D	Specifies whether Chezy map arrays will be written to SDS-file. Default: Chezy map arrays will be written.
<u>NO_TOTAL_WATER_DEPTH</u>	D	Specifies whether depth map arrays (HU and HV) will be written to SDS-file. Default: depth map arrays will be written.
<u>NO_TRANSPORT</u>	D	Specifies whether transport-related map arrays (RP) will be written to SDS-file. Default: transport-related map arrays will be written.

TURBULENCE	D	Specifies whether turbulence arrays have to be written to SDS-file. Default: no turbulence arrays will be written.
WEIRS	D	Specifies whether map arrays for weirs (local velocity, flow-through height, discharge, energy loss) have to be written to SDS-file. Default: no map arrays arrays for weirs will be written.
HYDRO	D	Specifies whether map arrays for non-hydrostatic pressure and vertical velocities have to be written to SDS-file. Default: no map arrays for non-hydrostatic pressure and vertical velocities will be written.
VISCOSITY	D	Specifies whether map arrays for the effective horizontal viscosity have to be written to SDS-file. This can only in case of HLES (otherwise it is constant during the simulation) Default: no map arrays for effective horizontal viscosity will be written.
WIND	D	Specifies whether map arrays for the wind velocities have to be written to SDS-file. This can only be used in the case that there is space-varying wind data available and the wind velocities are available on the wind file itself. If the information on the wind file is provided as stresses, the wind velocities are not available and will not be written and a warning will occur. Default: no map arrays for wind velocities will be written.
PRESSURE	D	Specifies whether map arrays for the wind pressures have to be written to SDS-file. This can only be used in the case that there is space-varying wind data available. Otherwise a warning will occur. Default: no map arrays for wind pressures will be written.

### 2.17.2 HISTORIES (optional)

In this subsection time first, time interval and time last to write history-data to the SDS-file are specified.

HISTORIES

TFHISTO = [val]      TIHISTO = [val]      TLHISTO = [val]  
NO\_BACKTRANSFORM

**Explanation:**

- |                         |   |  |
|-------------------------|---|--|
| <u>TFHISTO</u> = [val]  | O | Time first to write history-data to SDS-file.  |
| <u>TIHISTO</u> = [val]  | O | Time interval to write history-data to SDS-file.   |
| <u>TLHISTO</u> = [val]  | O | Time last to write history-data to SDS-file.<br>(All times in elapsed simulation minutes)  |
| <u>NO_BACKTRANSFORM</u> | D | If this keyword is specified, the horizontal velocities to be written to SDS-file for time-histories will not be transformed from curvilinear to Cartesian coordinates.<br>Default: the horizontal velocities will be transformed from curvilinear to Cartesian coordinates and then written to SDS-file for time-histories. |

### 2.17.3 WEIR\_HISTORIES (optional)

In this subsection time first, time interval and time last to write history-data for weirs (flow-conditions on both sides of the weir and at the crest of the weir itself, discharge, energy loss) to the SDS-file are specified.

WEIR\_HISTORIES

TFWEIR = [val]      TIWEIR = [val]      TLWEIR = [val]

**Explanation:**

- |                       |   |   |
|-----------------------|---|---|
| <u>TFWEIR</u> = [val] | O | Time first to write history-data for weirs to SDS-file.   |
| <u>TIWEIR</u> = [val] | O | Time interval to write history-data for weirs to SDS-file.  |
| <u>TLWEIR</u> = [val] | O | Time last to write history-data for weirs to SDS-file.<br>(All times in elapsed simulation minutes) |

Note: In TRIWAQ computations with multiple layers, the calculations for weirs are performed using depth averaged quantities. Therefore the output quantities will not show multiple layers but will contain depth averaged quantities too.

## 2.17.4 INTEGRATION (optional)

In this subsection time first, time interval and time last to write integrals to the SDS-file are specified.

### INTEGRATION

TFINTEGR = [val]      TIINTEGR = [val]      TLINTEGR = [val]

TYPE = [text]

ACCURACY = [val]

INITIALIZE\_START\_POSITION

### Explanation:

<u>TFINTEGR</u> =[val]	O	Time first to write integrals to SDS-file.
<u>TIINTEGR</u> =[val]	O	Time interval to write integrals to SDS-file.
<u>TLINTEGR</u> =[val]	O	Time last to write integrals to SDS-file. (All times are in elapsed simulation minutes.)
<u>TYPE</u> =[text]	D	Specifies the integration type that has to be performed. Possible values are: 'Euler'           : the Euler time integrals are written to SDS file; 'Lagrange'       : the Lagrange time integrals (displacements) are written to SDS file; 'Both'            : both Euler and Lagrange time integrals are written to SDS file. Default: 'Euler'.
<u>ACCURACY</u> =[val]	D	Accuracy value to determine Lagrangian time integrals. Default: $10^{-8}$ .
<u>INITIALIZE_START_POSITION</u>	D	Specifies whether the Lagrangian displacements have to be reset for each time integration interval or whether the displacements have to be accumulated over the complete simulation period. If the flag INITIALIZE_START_POSITIONS is specified, then the displacements are reset for each integration interval, otherwise the displacements will be accumulated.

- Notes: - See for integration also Section 1 of this User's Guide WAQUA: GENERAL INFORMATION.  
 - Overlapping time periods for integrals are not possible.

### 2.17.5 RESTART (optional)

In this subsection time first, time interval and time last to write restart data to the SDS-file are specified.

#### RESTART

TFRESTART = *[val]*      TIRESTART = *[val]*      TLRESTART = *[val]*

#### **Explanation:**

<u>TFRESTART</u>	O	Time first to write restart data to SDS file
<u>TIRESTART</u>	M	Time interval to write restart data to SDS file
<u>TLRESTART</u>	O	Time last to write restart data to SDS file (All times in elapsed simulation minutes.)

### 2.17.6 HARMONIC\_TIDE (optional)

This subsection gives the user the opportunity to employ the harmonic analysis of tides based on the computed water level or physical (vertically averaged) flow velocity series throughout the model. The results of this analysis, i.e. tidal constants (mean water level or current of tide, astronomical amplitude and improved kappa-number or local phase lag) throughout the grid, are written to the SDS-file. The time step to be used in the tidal analysis is given in subsection METHODVARIABLES (sec. 2.11.1.4). In this subsection the harmonic constants and space-varying splitting factors are given.

#### HARMONIC\_TIDE

##### GENERAL

OMEGA = *<[val]>*

DATA = *[text]*

TFRAMEHARMON = *[val1][val2]*

##### SPLITTING\_RULE

SPKONE

SPNTWO

SPSTWO

SPTWOM

#### **Explanation:**



OMEGA = < [val] >	M	The names of the angular velocities are given here for $K$ harmonic components in trigonometric series describing the astronomical tide. There are 195 commonly used names available, for instance 'M2', 'S2' and 'NU2'. The component 'A0' is written to the SDS-file by default. For a complete list of harmonic constants refer to the Appendix D.
DATA = [text]	D	Specifies the tidal data for which the harmonic analysis has to be performed. Possible values are: <ul style="list-style-type: none"> <li>- '<u>watlevel</u>' : water level</li> <li>- '<u>uvelocity</u>' : physical <math>U</math>-component of vertically averaged flow velocity</li> <li>- '<u>vvelocity</u>' : physical <math>V</math>-component of vertically averaged flow velocity</li> </ul> <p>Default = 'watlevel'.</p>
TFRAMEHARMON = [val1][val2]	O	Time first and time last (in minutes) to analyse the tidal data. As default, the time series starts at TSTART and ends at TSTOP.
SPLITTING_RULE	O	To indicate that one or more definitions of splitting rules will follow.

### 2.17.6.1 SPKONE (optional)

K1-splitting rule to be used for the computation of astronomical amplitude and local phase lag of the component P1. This keyword should be followed by the subkeywords AMPLITUDE and PHASE, respectively.

SPKONE

AMPLITUDE

PHASE

#### Explanation:

AMPLITUDE	O	The splitting factor defined as the ratio between the amplitudes of P1 and K1 = $A_{P1}/A_{K1}$
-----------	---	---

AMPLITUDE

GLOBAL

LOCAL

## GLOBAL (mandatory)

### GLOBAL

LAYOUT  
| CONST\_VALUES = [val]  
<  
| VARIABLE\_VALUES = <[val]>

### Explanation:

<u>CONST_VALUES</u> = [val]	D	See paragraph 2.1.2.1 Default = 0.1755/0.5305
<u>VARIABLE_VALUES</u> = < [val] >	O	See paragraph 2.1.2.1
<u>LAYOUT</u> = [ival]	D	See paragraph 2.1.2.1 Default = 1

## LOCAL (mandatory)

See paragraph 2.1.2.2 for this subsection.

### Explanation:

<u>PHASE</u>	O	The splitting factor defined as the difference between the phases in degrees of P1 and K1 $= g_{P1} - g_{K1}$
--------------	---	--

### PHASE

GLOBAL  
LOCAL

## GLOBAL (mandatory)

### GLOBAL

LAYOUT  
| CONST\_VALUES = [val]  
<  
| VARIABLE\_VALUES = <[val]>

### Explanation:

CONST_VALUES = <i>[val]</i>	D	See paragraph 2.1.2.1 Default = 0.0 deg
VARIABLE_VALUES = < <i>[val]</i> >	O	See paragraph 2.1.2.1
LAYOUT = <i>[val]</i>	D	See paragraph 2.1.2.1 Default = 1

**LOCAL (mandatory)**

See paragraph 2.1.2.2 for this subsection.

**2.17.6.2 SPNTWO (optional)**

N2-splitting rule to be used for the computation of astronomical amplitude and local phase lag of the component NU2. This keyword should be followed by the subkeywords AMPLITUDE and PHASE, respectively.

SPNTWO  
AMPLITUDE  
PHASE

**Explanation:**

AMPLITUDE	O	The splitting factor defined as the ratio between the amplitudes of NU2 and N2 = $A_{NU2}/A_{N2}$
-----------	---	---

AMPLITUDE  
GLOBAL  
LOCAL

**GLOBAL (mandatory)**

GLOBAL  
LAYOUT  
| CONST\_VALUES = *[val]*  
<  
| VARIABLE\_VALUES = <*[val]*>

**Explanation:**

CONST_VALUES = <i>[val]</i>	D	See paragraph 2.1.2.1 Default = 0.0341/0.1759
-----------------------------	---	--

- |                             |   |                                      |
|-----------------------------|---|--------------------------------------|
| VARIABLE_VALUES = < [val] > | O | See paragraph 2.1.2.1                |
| LAYOUT = [ival]             | D | See paragraph 2.1.2.1<br>Default = 1 |

### LOCAL (mandatory)

See paragraph 2.1.2.2 for this subsection.

#### Explanation:

- |       |   |   |
|-------|---|---|
| PHASE | O | The splitting factor defined as the difference between the phases in degrees of NU2 and N2 = $g_{NU2} - N2$ |
|-------|---|---|

#### PHASE

GLOBAL

LOCAL

### GLOBAL (mandatory)

#### GLOBAL

LAYOUT

| CONST\_VALUES = [val]

<

| VARIABLE\_VALUES = <[val]>

#### Explanation:

- |                             |   |  |
|-----------------------------|---|--|
| CONST_VALUES = [val]        | D | See paragraph 2.1.2.1<br>Default = 0.0 deg |
| VARIABLE_VALUES = < [val] > | O | See paragraph 2.1.2.1                      |
| LAYOUT = [ival]             | D | See paragraph 2.1.2.1<br>Default = 1       |

### LOCAL (mandatory)

See paragraph 2.1.2.2 for this subsection.



PHASE

- O The splitting factor defined as the difference between the phases in degrees of K2 and S2  
 $= g_{K2} - g_{S2}$

PHASE

GLOBAL

LOCAL

### GLOBAL (mandatory)

GLOBAL

LAYOUT

| CONST\_VALUES = *[val]*  
 <  
 | VARIABLE\_VALUES = <*[val]*>

#### Explanation:

- |                                    |   |  |
|------------------------------------|---|--|
| CONST_VALUES = <i>[val]</i>        | D | See paragraph 2.1.2.1<br>Default = 0.0 deg |
| VARIABLE_VALUES = < <i>[val]</i> > | O | See paragraph 2.1.2.1                      |
| LAYOUT = <i>[ival]</i>             | D | See paragraph 2.1.2.1<br>Default = 1       |

### LOCAL (mandatory)

See paragraph 2.1.2.2 for this subsection.

#### 2.17.6.4 SPTWOM (optional)

2M-splitting rule to be used for the computation of astronomical amplitude and local phase lag of the component LABDA2. This keyword should be followed by the subkeywords AMPLITUDE and PHASE, respectively.

SPTWOM

AMPLITUDE

PHASE

#### Explanation:

AMPLITUDE

- O The splitting factor defined as the ratio between the amplitudes of LABDA2 and 2MN2  
 $= A_{LABDA2}/A_{2MN2}$

AMPLITUDEGLOBALLOCAL**GLOBAL (mandatory)**GLOBALLAYOUT

| CONST\_VALUES = [val]  
 <  
 | VARIABLE\_VALUES = <[val]>

**Explanation:**

CONST\_VALUES = [val]

- D See paragraph 2.1.2.1  
Default = 0.0066/0.0251

VARIABLE\_VALUES = &lt; [val] &gt;

- O See paragraph 2.1.2.1

LAYOUT = [ival]

- D See paragraph 2.1.2.1  
Default = 1

**LOCAL (mandatory)**

See paragraph 2.1.2.2 for this subsection.

**Explanation:**PHASE

- O The splitting factor defined as the difference between the phases in degrees of LABDA2 and 2MN2  
 $= g_{LABDA2} - g_{2MN2}$

PHASEGLOBALLOCAL

## GLOBAL (mandatory)

### GLOBAL

```
LAYOUT  
| CONST_VALUES = [val]  
<  
| VARIABLE_VALUES = <[val]>
```

### Explanation:

<u>CONST_VALUES</u> = [val]	D	See paragraph 2.1.2.1 Default = 0.0 deg
<u>VARIABLE_VALUES</u> = < [val] >	O	See paragraph 2.1.2.1
<u>LAYOUT</u> = [ival]	D	See paragraph 2.1.2.1 Default = 1

## LOCAL (mandatory)

See paragraph 2.1.2.2 for this subsection.

- Notes:
- Further details on harmonic analysis of tides can be found in User's Guide WAQUA: General Information.
  - When harmonic constants are specified in a given simulation year (see Sec. 2.8.1.1), the tidal constants are corrected by means of nodal modulations (nodal amplitude factor and astronomical argument) with respect to January 1st, 1900 at 0000 h.
  - In order to match the timezone of the harmonic constants with the timezone of WAQUA, the time shift given in subsection HARMONIC (Sec.2.9.1.5) should be determined.
  - The minimum length of given time series required to isolate two components apart in frequency  $\Delta\omega$  is  $2\pi/\Delta\omega$  (Rayleigh criterion).
  - The maximum time step required to have a non-singular solution equals  $\pi\omega_{max}$ , with  $\omega_{max} = \max \left\{ \omega_i \mid i = 1, \dots, K \right\}$

## 2.17.7 KALMAN\_HISTORIES (optional)

When this option is given, kalman histories will be written to the SDS-file during a simulation. If this keyword is specified, at least the subkeyword TIKHISTORIES should also be defined. Furthermore, the subkeywords TFKHISTORIES and TLKHISTORIES may be specified.

### KALMAN\_HISTORIES

```
TFKHISTORIES = [val]  
TIKHISTORIES = [val]
```



TLKHISTORIES = *[val]*

### Explanation:

<u>TFKHISTORIES</u>	D	Time in minutes to start the storage of boundary history values (Time First). Default = TSTART
<u>TIKHISTORIES</u>	M	Time interval in minutes to store the boundary history values.
<u>TLKHISTORIES</u>	D	Time in minutes to end the storage of boundary history values (Time Last). Default = TSTOP

Note: More info can be found in “Kalman Filtering with WAQUA” in the section Kalman filtering in the users documentation.

## 2.17.8 CALCMAXVALUES (optional)

When this option is given, maximum values will be computed during the simulation and will be written to the SDS-file. If this keyword is specified, at least one of the subkeywords MAX\_WATLEVEL, MAX\_UVELOC, MAX\_VVELOC, MAX\_FLOWMAGN, MAX\_SALINITY, MAX\_TEMPERAT and MAX\_CONCENTR should also be defined. For each of these keywords the option EXTRA\_FIELDS may be specified to write extra information about the flow at the moment the maximum is attained. If the keyword EXTRA\_FIELDS is present, at least one of the subkeywords WATLEVEL, XVELOC, YVELOC, FLOWMAGN, SALINITY, TEMPERATURE and CONCENTRATION should also be present.

### CALCMAXVALUES

#### TIMES

<u>TFMAXVAL</u> = <i>[val]</i>	<u>TIMAXVAL</u> = <i>[val]</i>	<u>TLMAXVAL</u> = <i>[val]</i>
<u>MAX_WATLEVEL</u>	<u>EXTRA_FIELD</u> = <i>[fields]</i>	
<u>MAX_UVELOC</u>	<u>EXTRA_FIELD</u> = <i>[fields]</i>	
<u>MAX_VVELOC</u>	<u>EXTRA_FIELD</u> = <i>[fields]</i>	
<u>MAX_FLOWMAGN</u>	<u>EXTRA_FIELD</u> = <i>[fields]</i>	
<u>MAX_SALINITY</u>	<u>EXTRA_FIELD</u> = <i>[fields]</i>	
<u>MAX_TEMPERAT</u>	<u>EXTRA_FIELD</u> = <i>[fields]</i>	
<u>MAX_CONCENTR</u>	<u>EXTRA_FIELD</u> = <i>[fields]</i>	

Where *[fields]* is one or more of the keywords:

WATLEVEL  
XVELOC  
YVELOC

FLOWMAGN  
SALINITY  
TEMPERATURE  
CONCENTR

**Explanation:**

TIMES	M	Times at which maximum values are asked
TFMAXVAL	D	Time first to compute/update maximum values Default = 0.0
TIMAXVAL	O	Time interval to compute/update maximum values
TLMAXVAL	O	Time last to compute/update maximum values (All times in elapsed simulation minutes.)
MAX_WATLEVEL	O	Flag for activating the computation of maximum water levels during the simulation and writing these and the corresponding time to the SDS file.
MAX_UVELOC	O	Flag for activating the computation of maximum (vertically averaged) velocities in U direction during the simulation and writing these and the corresponding time to the SDS file.
MAX_VVELOC	O	Flag for activating the computation of maximum (vertically averaged) velocities in V direction during the simulation and writing these and the corresponding time to the SDS file.
MAX_FLOWMAGN	O	Flag for activating the computation of maximum (vertically averaged) flow magnitudes (the interpolated velocity in the water level location) during the simulation and writing these and the corresponding time to the SDS file.
MAX_SALINITY	O	Flag for activating the computation of maximum (vertically averaged) salinity during the simulation and writing these and the corresponding time to the SDS file.
MAX_TEMPERAT	O	Flag for activating the computation of maximum (vertically averaged) temperature during the simulation and writing these and the corresponding time to the SDS file.

MAX_CONCENTR	O	Flag for activating the computation of maximum (vertically averaged) concentrations (for all constituents not being salt or temperature) during the simulation and writing these and the corresponding time to the SDS file.
WATLEVEL	O	Flag for writing waterlevel to the SDS file at the moment the maximum value is attained.
XVELOC	O	Flag for writing (vertically averaged) velocity in X direction to the SDS file at the moment that the maximum value is attained.
YVELOC	O	Flag for writing (vertically averaged) velocity in Y direction to the SDS file at the moment that the maximum value is attained.
TEMPERAT	O	Flag for writing (vertically averaged) temperature to the SDS file at the moment that the maximum value is attained.
CONCENTR	O	Flag for writing (vertically averaged) concentration (for all constituents not being salt or temperature) to the SDS file at the moment that the maximum value is attained.

### 2.17.9 CALCMINVALUES (optional)

When this option is given, minimum values will be computed during the simulation and will be written to the SDS-file. If this keyword is specified, at least one of the subkeywords MIN\_WATLEVEL, MIN\_UVELOC, MIN\_VVELOC, MIN\_FLOWMAGN, MIN\_SALINITY, MIN\_TEMPERAT and MIN\_CONCENTR should also be defined. For each of these keywords the option EXTRA\_FIELDS may be specified to write extra information about the flow at the moment the minimum is attained. If the keyword EXTRA\_FIELDS is present, at least one of the subkeywords WATLEVEL, XVELOC, YVELOC, FLOWMAGN, SALINITY, TEMPERATURE and CONCENTRATION should also be present.

#### CALCMINVALUES

##### TIMES

<u>TFMINVAL</u> = [val]	<u>TIMINVAL</u> = [val]	<u>TLMINXVAL</u> = [val]
<u>MIN_WATLEVEL</u>	<u>EXTRA_FIELD</u> = [fields]	
<u>MIN_UVELOC</u>	<u>EXTRA_FIELD</u> = [fields]	
<u>MIN_VVELOC</u>	<u>EXTRA_FIELD</u> = [fields]	
<u>MIN_FLOWMAGN</u>	<u>EXTRA_FIELD</u> = [fields]	
<u>MIN_SALINITY</u>	<u>EXTRA_FIELD</u> = [fields]	
<u>MIN_TEMPERAT</u>	<u>EXTRA_FIELD</u> = [fields]	
<u>MIN_CONCENTR</u>	<u>EXTRA_FIELD</u> = [fields]	

Where [fields] is one or more of the keywords:

WATLEVEL  
XVELOC  
YVELOC  
FLOWMAGN  
SALINITY  
TEMPERATURE  
CONCENTR

**Explanation:**

TIMES	M	Times at which minimum values are asked
TFMINFVAL	D	Time first to compute/update minimum values Default = 0.0
TIMINVAL	O	Time interval to compute/update minimum values
TLMINVAL	O	Time last to compute/update minimum values (All times in elapsed simulation minutes.)
MIN_WATLEVEL	O	Flag for activating the computation of minimum water levels during the simulation and writing these and the corresponding time to the SDS file.
MIN_UVELOC	O	Flag for activating the computation of minimum (vertically averaged) velocities in U direction during the simulation and writing these and the corresponding time to the SDS file.
MIN_VVELOC	O	Flag for activating the computation of minimum (vertically averaged) velocities in V direction during the simulation and writing these and the corresponding time to the SDS file.
MIN_FLOWMAGN	O	Flag for activating the computation of minimum (vertically averaged) flow magnitudes (the interpolated velocity in the water level location) during the simulation and writing these and the corresponding time to the SDS file.
MIN_SALINITY	O	Flag for activating the computation of minimum (vertically averaged) salinity during the simulation and writing these and the corresponding time to the SDS file.

---

MIN_TEMPERAT	O	Flag for activating the computation of minimum (vertically averaged) temperature during the simulation and writing these and the corresponding time to the SDS file.
MIN_CONCENTR	O	Flag for activating the computation of minimum (vertically averaged) concentrations (for all constituents not being salt or temperature) during the simulation and writing these and the corresponding time to the SDS file.
WATLEVEL	O	Flag for writing waterlevel to the SDS file at the moment the minimum value is attained.
XVELOC	O	Flag for writing (vertically averaged) velocity in X direction to the SDS file at the moment that the minimum value is attained.
FLOWMAGN	O	Flag for writing (vertically averaged) flow magnitude to the SDS file at the moment that the minimum value is attained.
SALINITY	O	Flag for writing (vertically averaged) salinity to the SDS file at the moment that the minimum value is attained.
TEMPERAT	O	Flag for writing (vertically averaged) temperature to the SDS file at the moment that the minimum value is attained.
CONCENTR	O	Flag for writing (vertically averaged) concentration (for all constituents not being salt or temperature) to the SDS file at the moment that the minimum value is attained.

### 2.17.10 INCREMENTAL (optional)

This keyword enables class values output. This option is intended primarily for making animations of simulation results. In plotting results of a simulation a user often has the option to change the vertical scale or range of colors of the plot afterwards. However, this requires storage of all simulation output-values at a sufficiently small time-interval, which results in prohibitively large files when smooth animations are required.

In the incremental-option, the vertical scale of the plot is specified beforehand. This allows the program to store a single code only instead of the precise value for each grid point. It allows to compress the output further by recording only the changes of the codes at successive output-times, instead of storing the values of all times.

The incremental-option results are stored on the SDS-file with the class-boundaries used per output-variable, plus the class-values per grid point per output time-step (when changed w.r.t. the previous output time-step). These results can be visualized by Waqview.

INCREMENTAL

TFINCR = [val]      TIINCR = [val]      TLINCR = [val]  
H = [val1][val2][val3]...  
ZETA = [val1][val2][val3]...  
UPHYS = [val1][val2][val3]...  
VPHYS = [val1][val2][val3]...  
VELMAG = [val1][val2][val3]...  
VELANG = [val1][val2][val3]...

**Explanation:**

TFINCR	○	Time first to write incremental output values
TIINCR	○	Time interval to write incremental output values
TLINCR	○	Time last to write incremental output values (All times in elapsed simulation minutes.)
H	○	Class-boundaries for output-variable H (total water depth in waterlevel location). The first class (color in plot) concerns range of values (-inf, val1), the second color concerns range (val1, val2), and so on until the last class which concerns the range of the highest value given up to +infinity.
ZETA	○	Class-boundaries for output-variable ZETA (waterlevel). See output-variable H for a description of the class-values.
UPHYS	○	Class-boundaries for output-variable UPHYS (flow velocity in physical X-direction in waterlevel location). See output-variable H for a description of the class-values.
VPHYS	○	Class-boundaries for output-variable VPHYS (flow velocity in physical Y-direction in waterlevel location). See output-variable H for a description of the class-values.
VELMAG	○	Class-boundaries for output-variable VELMAG (magnitude of flow-velocity vector in waterlevel location). See output-variable H for a description of the class-values.
VELANG	○	Class-boundaries for output-variable VELANG (angle of flow-velocity vector in degrees ([0,360]) w.r.t. positive x-axis in waterlevel location). See output-variable H for a description of the class-values.

Notes: - The values for the class limits have to be defined in ascending order and it is not allowed to define more than 99 class limits.

## 2.18 PRINTOUTPUT (optional)

Generate print output during simulation. In this section a selection can be made for data types for which computed space varying data has to be printed. Also the times for printing space varying data and computed values in the CHECKPOINTS (section 2.9.2 and 2.11.3) can be specified. Time series (histories), spatial data fields (map data) and experiment status will be printed. PRINTOUTPUT has three subsections.

### PRINTOUTPUT

#### FLOW

#### TRANSPORT

#### CONTROL

### 2.18.1 FLOW (optional)

In FLOW hydrodynamic print output is specified.

#### FLOW

#### WATLEVEL

#### UVELOCITY

#### VVELOCITY

#### WVELOCITY

#### VELMAGWL

#### VELMAGU

#### VELMAGV

#### CHEZY

#### ROUGHNESS

### Explanation:

WATLEVEL	D	Flag for water level print output. Default = NO WATERLEVEL
UVELOCITY	D	Flag for U-velocity print output. Default = NO UVELOCITY
VVELOCITY	D	Flag for V-velocity print output. Default = NO VVELOCITY
WVELOCITY	D	Flag for omega-velocity print output. Default = NO WVELOCITY
VELMAGWL	D	Flag for velocity magnitude print output at water level locations. Default = NO VELMAGWL
VELMAGU	D	Flag for velocity magnitude print output at U-velocity locations. Default = NO VELMAGU





TFRAMESTAT=[val1][val2][val3]

- Time first, time interval and time last (in minutes) to print the experiment status.

Default value's:

TF = TSTART (val1)  
TI = TSTEP (val2)  
TL = TSTOP (val3)

TFRAMEITEROUTPUT=[val1][val2][val3]

- Time first, time interval and time last (in minutes) to print the residuals.

Default value's:

TF = TSTART (val1)  
TI = TSTEP \* 60 (val2)  
TL = TSTOP (val3)

## **IGNORE (optional)**

By means of this option the checking and processing of a specific part of the input can be suppressed.

IGNORE  
TRANSPORT

### **Explanation:**

TRANSPORT

Checking and processing TRANSPORT-part will be suppressed.

Note: This option will not suppress the checking of the input syntax by the general part of the pre-processor.

## 2.19 Example input description for Roughcombination

```
#####  
#  
# Rough.karak : Rough karakteristieken voor de ROUGHCOMBINATION method in Waqua  
#           De r_code verwijst naar de r_code in de area-u en area-v files  
#  
#           De vegetatie waarden zijn afkomstig van het Handboek  
#           Stromingsweerstand vegetatie in uiterwaarden Deel 1 en 2  
#           Riza rapport 2003.028 en Riza rapport 2003.029  
#  
# Versie 0.51: Datum 30-06-2004 Aanpassingen diep en ondiep getijdewater (MS)  
# Versie 0.5 : Datum 04-06-2004 Aanpassingen na de testen van wagrou in Waqua  
#           minima, maxima en default waarden (MS)  
# Versie 0.4 : Datum 13-04-2004 Opname nav alle ecotopenstelsels (MS)  
# Versie 0.3 : Datum 07-04-2004 Default minima en maxima (MSn)  
# Versie 0.2 : Datum 23-04-2004 Heggen en individuele bomen (MS)  
# Versie 0.1 : Datum 24-03-2004 Eerste opzet van dit bestand (Martin Scholten)  
#  
#####  
#  
# CODE 1-50 : Formulering voor bebouwing en hoogwatervrije terreinen  
#           : Deze formulering vraagt geen invoer parameters in rough.karak  
#  
#####  
#  
# CODE 51-100 : Niet gedefinieerd  
#  
#####  
#  
# CODE 101-300 : Ruwheids formulering volgens de formule van White-Colebrook  
# r_code      : de ruwheids code  
# a           : k-Nikuradse (normaal of eb) (0.0001 - 0.20 - 100.)  
# b           : k-Nikuradse (vloed) (0.0001 - 0.20 - 100.)  
# c           : geen betekenis  
# d           : geen betekenis  
#  
r_code = 101 a = 0.20           # default waarde  
r_code = 102 a = 0.40           # diepe bedding  
r_code = 103 a = 0.15           # ondiepe bedding  
r_code = 104 a = 0.15           # strang  
r_code = 105 a = 0.20           # nevengeul  
r_code = 106 a = 0.05           # plas/haven/slikkige oever  
r_code = 111 a = 0.15           # kribvakstrand/zandplaat/grindplaat  
r_code = 112 a = 0.40           # ruwe oever
```

```

r_code = 113 a = 0.30          # steenbekleding
r_code = 114 a = 0.60          # bebouwd/verhard terrein
r_code = 115 a = 1.00          # bebouwd terrein
r_code = 116 a = 0.20          # verhard terrein
r_code = 121 a = 0.10          # akker
r_code = 122 a = 0.25          # strooisel
#r_code = 299 a = 0.20 b = 0.25 # eb en vloed (voorbeeld)}
#
#=====
#
# CODE 301-500 : Ruwheids formulering volgens de formule van Manning
# r_code      : de ruwheids code
# a           : Manning (normaal of eb) (0.001 - 0.0263 - 100.)
# b           : Manning (vloed) (0.001 - 0.0263 - 100.)
# c           : geen betekenis
# d           : geen betekenis
#
r_code = 301 a = 0.0263        # default waarde
r_code = 302 a = 0.0263        # diepe meerbodem
r_code = 303 a = 0.0283        # ondiepe meerbodem
r_code = 304 a = 0.024         # diep getijdewater
r_code = 305 a = 0.022        # ondiep getijdewater
#r_code = 499 a = 0.0263 b = 0.0283 # eb en vloed (voorbeeld)}
#
#=====
#
# CODE 501-600 : Chezy waarde
# r_code      : de ruwheids code
# a           : Chezy (normale of eb) (0.01 - 45. - 100.)
# b           : Chezy (vloed) (0.01 - 45. - 100.)
# c           : geen betekenis
# d           : geen betekenis
#
r_code = 501 a = 45.0          # default waarde
#r_code = 599 a = 45.0 b = 40.0 # eb en vloed (voorbeeld)
#
#=====
#
# CODE 601-900 : Ruwheids methode voor het zomerbed van een rivier
# r_code      : de ruwheids code
# a           : alfa (normaal of eb) (0.001 - 0.1 - 1.)
# b           : beta (normaal of eb) (0.1 - 2.5 - 100.)
# c           : alfa (vloed) (alleen voor testen) (0.001 - 0.1 - 1.)
# d           : beta (vloed) (alleen voor testen) (0.1 - 2.5 - 100.)
#

```

```

r_code = 601 a = 0.1 b = 2.5 # zomerbed default
#
#=====
#
# CODE 901-1200 : Niet gedefinieerd
#
#=====
#
# CODE 1201-1400 : Ruwheids formulering voor door- en overstroomde vegetatie
# r_code      : de ruwheids code
# a          : de vegetatie hoogte (0.001 - 0.2 - 50.)
# b          : de vegetatie dichtheid (0.0001 - 0.2 - 100.)
# c          : drag coefficient (0.1 - 1.8 - 10.)
# d          : k-Nikuradse (onderlaag begroeiing) (0.001 - 0.2 - 100.)
#
r_code = 1201 a = 0.06 b = 45. c = 1.8 d = 0.1 # productiegrasland
r_code = 1202 a = 0.10 b = 12. c = 1.8 d = 0.1 # natuurlijk gras/hooiland
r_code = 1203 a = 0.20 b = 15. c = 1.8 d = 0.1 # verruigd grasland
r_code = 1211 a = 0.30 b = 3. c = 1.8 d = 0.1 # akkerdistelruigte
r_code = 1212 a = 0.56 b = 0.23 c = 1.8 d = 0.1 # droge ruigte
r_code = 1213 a = 0.50 b = 0.56 c = 1.8 d = 0.1 # dauwbraamruigte
r_code = 1214 a = 0.95 b = 0.13 c = 1.8 d = 0.1 # wilgenroosje ruigte
r_code = 1215 a = 2.00 b = 0.16 c = 1.8 d = 0.1 # rietruigte
r_code = 1221 a = 0.35 b = 0.25 c = 1.8 d = 0.1 # natte ruigte homogeen
r_code = 1222 a = 0.30 b = 1.2 c = 1.8 d = 0.1 # zegge homogeen
r_code = 1223 a = 1.00 b = 0.4 c = 1.8 d = 0.1 # rietgras homogeen
r_code = 1224 a = 0.50 b = 1.2 c = 1.8 d = 0.1 # biezen homogeen
r_code = 1225 a = 1.50 b = 0.35 c = 1.8 d = 0.1 # lisdodde homogeen
r_code = 1226 a = 2.50 b = 0.37 c = 1.8 d = 0.1 # riet homogeen
r_code = 1231 a = 6.00 b = 0.13 c = 1.5 d = 0.4 # zachthoutstruweel
r_code = 1232 a = 3.00 b = 0.041 c = 1.5 d = 0.4 # griend
r_code = 1233 a = 5.00 b = 0.17 c = 1.5 d = 0.4 # doornstruweel
r_code = 1241 a = 10.00 b = 0.011 c = 1.5 d = 0.3 # productiebos hardhout
r_code = 1242 a = 10.00 b = 0.010 c = 1.5 d = 0.3 # productiebos zachthout
r_code = 1243 a = 10.00 b = 0.016 c = 1.5 d = 0.3 # productiebos naaldhout
r_code = 1244 a = 10.00 b = 0.023 c = 1.5 d = 0.4 # hardhoutooibos
r_code = 1245 a = 10.00 b = 0.028 c = 1.5 d = 0.6 # zachthoutooibos
r_code = 1246 a = 3.00 b = 0.024 c = 1.5 d = 0.2 # boomgaard laagstam
r_code = 1247 a = 6.00 b = 0.01 c = 1.5 d = 0.2 # boomgaard hoogstam
r_code = 1250 a = 0.15 b = 0.15 c = 1.8 d = 0.1 # pioniervegetatie
#
#=====
#
# CODE 1401-1500 : Niet gedefinieerd
#

```

```

#=====
#
# CODE 1501-1600 : Ruwheids formulering voor door- en overstroomde bomen
# r_code          : de ruwheids code
# a               : de vegetatie hoogte (0.5 - 10. - 50.)
# b               : drag coefficient (0.1 - 1.5 - 10.)
# c               : geen betekenis
# d               : geen betekenis
# In area file staat de dichtheid ( (de som van alle diameters) / celgrootte)
#
r_code = 1501 a = 1.00 b = 1.5 # individule bomen
r_code = 1502 a = 2.00 b = 1.5 # individule bomen
r_code = 1503 a = 3.00 b = 1.5 # individule bomen
r_code = 1504 a = 4.00 b = 1.5 # individule bomen
r_code = 1505 a = 5.00 b = 1.5 # individule bomen
r_code = 1506 a = 6.00 b = 1.5 # individule bomen
r_code = 1507 a = 7.00 b = 1.5 # individule bomen
r_code = 1508 a = 8.00 b = 1.5 # individule bomen
r_code = 1509 a = 9.00 b = 1.5 # individule bomen
r_code = 1510 a = 10.00 b = 1.5 # individule bomen
#
#=====
#
# CODE 1601-1700 : Ruwheids formulering voor door- en overstroomde heggen
# r_code          : de ruwheids code
# a               : de vegetatie hoogte (0.5 - 2.0 - 10.)
# b               : de vegetatie dichtheid (0.01 - 0.6 - 10.)
# c               : drag coefficient (0.1 - 1.5 - 10.)
# d               : overlaat coefficient (0.1 - 1.2 - 10.)
#
r_code = 1601 a = 1.00 b = 0.20 c = 1.5 d = 1.2 # heggen zeer open
r_code = 1602 a = 1.00 b = 0.60 c = 1.5 d = 1.2 # heggen open
r_code = 1603 a = 1.00 b = 1.00 c = 1.5 d = 1.2 # heggen dicht
r_code = 1604 a = 2.00 b = 0.20 c = 1.5 d = 1.2 # heggen zeer open
r_code = 1605 a = 2.00 b = 0.60 c = 1.5 d = 1.2 # heggen open
r_code = 1606 a = 2.00 b = 1.00 c = 1.5 d = 1.2 # heggen dicht
r_code = 1607 a = 3.00 b = 0.20 c = 1.5 d = 1.2 # heggen zeer open
r_code = 1608 a = 3.00 b = 0.60 c = 1.5 d = 1.2 # heggen open
r_code = 1609 a = 3.00 b = 1.00 c = 1.5 d = 1.2 # heggen dicht
r_code = 1610 a = 4.00 b = 0.20 c = 1.5 d = 1.2 # heggen zeer open
r_code = 1611 a = 4.00 b = 0.60 c = 1.5 d = 1.2 # heggen open
r_code = 1612 a = 4.00 b = 1.00 c = 1.5 d = 1.2 # heggen dicht
r_code = 1613 a = 5.00 b = 0.20 c = 1.5 d = 1.2 # heggen zeer open
r_code = 1614 a = 5.00 b = 0.60 c = 1.5 d = 1.2 # heggen open
r_code = 1615 a = 5.00 b = 1.00 c = 1.5 d = 1.2 # heggen dicht

```

```

r_code = 1616 a = 6.00 b = 0.20 c = 1.5 d = 1.2      # heggen zeer open
r_code = 1617 a = 6.00 b = 0.60 c = 1.5 d = 1.2      # heggen open
r_code = 1618 a = 6.00 b = 1.00 c = 1.5 d = 1.2      # heggen dicht
#
#=====
#
# CODE 1701-1800 : Niet gedefinieerd
#
#=====
#
# CODE 1801-1999 : Ruwheids combinatie voor r_codes van 101-600 en 1201-1400
# r_code          : de ruwheids code
# a               : de r_code van de eerste ruwheid (1 - 1221 - 1400)
# b               : de r_code van de tweede ruwheid (1 - 106 - 1900)
# c               : het percentage van de eerste r_code (0.001 - 0.75 - 0.999)
# d               : het percentage van de tweede r_code (0.001 - 0.25 - 0.999)
#
r_code = 1801 a = 1221 b = 106 c = 0.75 d = 0.25     # natte ruigte met 25% water
r_code = 1802 a = 1245 b = 1801 c = 0.05 d = 0.95     # 5% zachthoutoobos en 95%
# natte ruigte met 25% water
r_code = 1803 a = 1222 b = 122 c = 0.75 d = 0.25     # zegge met 25% strooisel
r_code = 1804 a = 1223 b = 106 c = 0.75 d = 0.25     # rietgras met 25% water
r_code = 1805 a = 1224 b = 106 c = 0.75 d = 0.25     # biezen met 25% water
r_code = 1806 a = 1225 b = 106 c = 0.75 d = 0.25     # lisdodde met 25% water
r_code = 1807 a = 1226 b = 122 c = 0.75 d = 0.25     # riet met 25% strooisel
#
#=====
#
# Einde rough.karak
#=====

```